

Tyler/Union

Mechanical Joint C110 Full Body

SUBMITTAL

SIZES:	2" through 48"
STANDARDS:	ANSI/AWWA C110/A21.10
PRESSURE RATING:	2"-24" @ 350 PSI; 30"-48" & all fittings with Flanged branches at 250 PSI
NSF-61:	Meets all requirements, UL Certified
COATING:	ANSI/AWWA C104/A21.4
CEMENT LINING:	ANSI/AWWA C104.A21.4, Double Available
EPOXY COATING:	ANSI/AWWA C116/A21.16
BARE:	Available
BOLTS:	ANSI/AWWA C111/A21.11
INSTALLATION:	AWWA C600

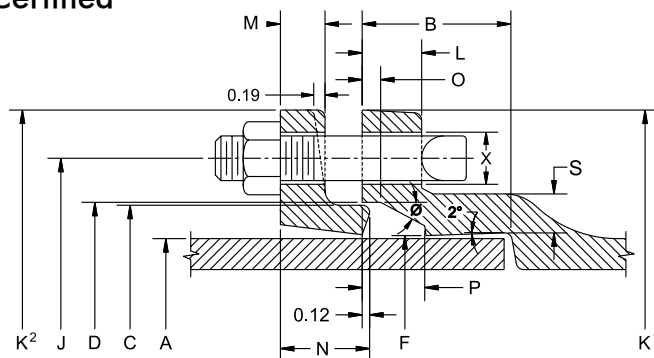

JOINT DIMENSIONS IN INCHES

Size	A	B	C	D	F	Ø	X	J	K ¹	K ²	L	M	N	O	P	S
2	2.50	2.50	3.39	3.50	2.61	28°	3/4	4.75	6.25	6.25	.75	.62	-----	.31	.63	.44
3	3.96	2.50	4.84	4.94	4.06	28°	3/4	6.19	7.69	7.69	.94	.62	1.37	.31	.63	.52
4	4.80	2.50	5.92	6.02	4.90	28°	7/8	7.50	9.12	9.12	1.00	.75	1.50	.31	.75	.65
6	6.90	2.50	8.02	8.12	7.00	28°	7/8	9.50	11.12	11.12	1.06	.88	1.63	.31	.75	.70
8	9.05	2.50	10.17	10.27	9.15	28°	7/8	11.75	13.37	13.37	1.12	1.00	1.75	.31	.75	.75
10	11.10	2.50	12.22	12.34	11.20	28°	7/8	14.00	15.69	15.62	1.19	1.00	1.75	.31	.75	.80
12	13.20	2.50	14.32	14.44	13.30	28°	7/8	16.25	17.94	17.88	1.25	1.00	1.75	.31	.75	.85
14	15.30	3.50	16.40	16.54	15.44	28°	7/8	18.75	20.31	20.25	1.31	1.25	2.00	.31	.75	.89
16	17.40	3.50	18.50	18.64	17.54	28°	7/8	21.00	22.56	22.50	1.38	1.31	2.06	.31	.75	.97
18	19.50	3.50	20.60	20.74	19.64	28°	7/8	23.25	24.83	24.75	1.44	1.38	2.13	.31	.75	1.05
20	21.60	3.50	22.70	22.84	21.74	28°	7/8	25.50	27.08	27.00	1.50	1.44	2.19	.31	.75	1.12
24	25.80	3.50	26.90	27.04	25.94	28°	7/8	30.00	31.58	31.50	1.62	1.56	2.31	.31	.75	1.22
30	32.00	4.00	33.29	33.46	32.17	20°	1 1/8	36.88	39.12	39.12	1.81	2.00	2.75	.38	1.00	1.50
36	38.30	4.00	39.59	39.76	38.47	20°	1 1/8	43.75	46.00	46.80	2.00	2.00	2.75	.38	1.00	1.80
42	44.50	4.00	45.79	45.96	44.67	20°	1 3/8	50.62	53.12	53.12	2.00	2.00	2.75	.38	1.00	1.95
48	50.80	4.00	52.09	52.26	50.97	20°	1 3/8	57.50	60.00	60.00	2.00	2.00	2.75	.38	1.00	2.20