

SUBMITTAL

(Current revisions for all Standards apply)

SIZES: For 6" to 12" AWWA C900 PVC, Cast Iron, and AWWA C151 Ductile pipe with 4" to 12" side flanged outlet with 3/4" tap at branch.

STANDARDS: Mechanical and *Flanged joints comply with ANSI/AWWA C153/A21.53 cast with tested and traceable ASTM A536 Ductile Iron. Ductile Iron Mechanical Joint Tapping Sleeves are produced in accordance with Tyler Union manufacturer's standard. Dimensions and specification ranges are per the standards provided herein.

Note: Recess dimensions are per Manufacturer's Standardization Society standard practice SP-60.

PRESSURE RATING:. 6"- 12" Assemblies rated @ 250 PSI.

GASKETS: SBR Mechanical Joint and Split gaskets are per ASTM D2000 - AA and ANSI/AWWA C111/21.11-7, armor tipped with coiled brass wire spring.

NSF-61: Meets all requirements

ASPHALTIC

COATING:..... ANSI/AWWA C104/A21.4-08

CEMENT LINING: Tapping Sleeves are unlined to ensure they fit over the pipe being tapped.

FLANGE:..... ANSI Class 125B

FLANGE THICKNESS:ANSI/AWWA C153/A21.53-06

BOLTS: ANSI/AWWA C111/A21.11-7

DEFLECTION:..... Deflection is not recommended

INSTALLATION: Per Tyler Union instructions as provided

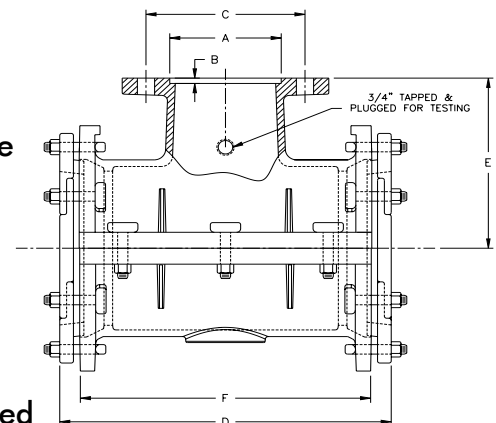

- Clean pipe, insert side gasket into back half of gasket grooves. Make sure ends are flush with or slightly protrude into the end gasket seating area.
- Bolt sleeve halves together and trim side gaskets as necessary. **MAKE SURE SLEEVE WILL ROTATE FREELY ON PIPE.**
- Install end gaskets, locating cut ends 90° from side gasket. If pipe is maximum OD, stretch gasket to make certain cut ends match with no gap in between.
- Install glands and bolts-rotate sleeve to desired position. Be sure pipe is centered inside the sleeve.
- Tighten gland bolts alternately, using 80 to 90 foot pounds.
- After assembly, **PRESSURE TEST ALL JOINTS BEFORE TAPPING.** If additional tightening is required, release pressure and relax tension on gland bolts before tightening side bolts.

Size	Dimensions						Pipe O.D. Range		DI
	A	B	C	D	E	F	Min.	Max.	
6x4	5.016	.250	7.50	15.75	8.00	12.75	6.85	7.15	104
6	7.016	.312	9.50	15.75	8.00	12.75	6.85	7.15	108
8x4	5.016	.250	7.50	16.50	9.00	13.375	9.00	9.35	134
8x6	7.016	.312	9.50	16.50	9.00	13.375	9.00	9.35	140
8	9.016	.312	11.75	16.50	9.00	13.375	9.00	9.35	148
10x4	5.016	.250	7.50	24.00	11.00	20.75	11.04	11.45	236
10x6	7.016	.312	9.50	24.00	11.00	20.75	11.04	11.45	240
10x8	9.016	.312	11.75	24.00	11.00	20.75	11.04	11.45	246
10	11.016	.312	14.25	24.00	11.00	20.75	11.04	11.45	257
12x4	5.016	.250	7.50	26.50	12.00	23.25	13.14	13.56	273
12x6	7.016	.312	9.50	26.50	12.00	23.25	13.14	13.56	286
12x8	9.016	.312	11.75	26.50	12.00	23.25	13.14	13.56	292
12x10	11.016	.312	14.25	26.50	12.00	23.25	13.14	13.56	303
12	13.016	.312	17.00	26.50	12.00	23.25	13.14	13.56	320