

# TUF GRIP™

## For Ductile Iron Pipe

*"A Proven Third Generation Mechanical Joint Restraint"*

MJ TUF Grip™ TLD



Torque Nut



*Tyler Union's TUF Grip restraints represent the culmination of 20 years of engineering and testing. As a 3rd generation restraint, TUF Grip is the best available technology in the Waterworks market for use in restraining Ductile Iron Pipe.*



Designed by Harold Kennedy & Associates, Inc.

**ISO 9001-2000  
Registered**



**UL Listed &  
FM Approved**

### TUF GRIP TLD • DUCTILE PIPE RESTRAINT

#### SPECIFICATIONS

- Designed and proven to restrain Ductile Iron Pipe 3 inches through 48 inches in diameter
- UL approved for 3 inch thru 24 inch applications
- FM approved for 4 inch thru 12 inch applications
- Cast with tested and traceable ASTM A536 compliant 65-45-12 ductile iron.
- TUF Grip deflection specification is 5° deflection through 12 inch and 3° deflection for 14 inch through 48 inch
- Wedges are heat treated and hardened to a minimum 370 BHN (Brinell Hardness)
- Restraint Gland and all components are rated and proven for a 2:1 safety factor based on pipe pressure rating
- Conforms to applicable requirements of ANSI/AWWA C110/A21.10, C111.A21.11, C153/A21.53
- Restrains any class of Ductile iron pipe conforming to ANSI/AWWA C151/A21.51
- Not recommended for use on Plain end fittings

#### FEATURES • ADVANTAGES

- Proven Restraint technology utilizing fewer wedges in frequently applied diameters
- Fewer wedges equate to less time in the trench and greatly reduced project cost
- Collar bolts and wedges pivot providing for a stronger engagement of pipe at a lower torque (45 to 60 foot pounds)
- Wedge Torque nuts twist off within a designed torque range so specialized tools are not required for installation
- TUF Grip restraints eliminate the need for costly and cumbersome Thrust Blocks and Tie-Rods
- Larger inside diameter of the gland provides for easier installation on out of round pipe
- Suitable for Potable and Wastewater applications
- Allows for disassembly just like a standard mechanical joint
- TUF Grip Ductile iron restraints are color coded black for easy recognition
- Designed by Harold Kennedy one of the foremost Restraint Engineers in the industry today

## Ductile Pipe Restraint

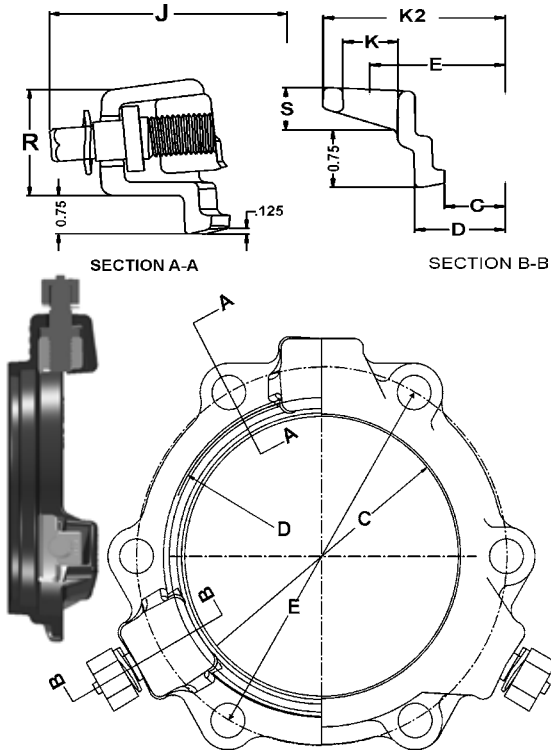

TUFGRIP<sup>TM</sup> MJ Restraint Dimensions

Size (inches)	C	D	E	F	J	K	R	S
3	4.08	4.88	6.19	7.67	9.82	3/4	2.20	0.86
4	4.93	5.92	7.50	8.98	10.67	7/8	2.20	0.73
6	7.03	8.02	9.50	10.98	12.77	7/8	2.24	0.82
8	9.18	10.17	11.75	13.23	14.92	7/8	2.28	0.82
10	11.23	12.22	14.00	15.70	16.97	7/8	2.37	0.93
12	13.33	14.32	16.25	17.95	19.07	7/8	2.40	0.93
14	15.44	16.40	18.75	20.43	21.18	7/8	2.57	0.91
16	17.54	18.50	21.00	22.88	23.28	7/8	2.57	1.05
18	19.64	20.60	23.25	25.43	25.38	7/8	2.57	1.05
20	21.74	22.70	25.50	27.50	27.48	7/8	2.66	1.15
24	25.94	26.90	30.00	32.00	31.68	7/8	2.72	1.35
30	32.18	33.30	36.88	39.42	39.78	1-1/8	3.86	1.53
36	38.48	39.60	43.75	46.29	46.08	1-1/8	3.86	1.53
42	44.68	45.80	50.62	53.62	53.08	1-3/8	4.56	2.05
48	50.98	52.10	57.50	60.50	59.28	1-3/8	4.56	2.05

## Ductile TUFGRIP<sup>TM</sup> Application Chart

Size (inches)	Part Number	Wedge Quantity	Bolt Quantity	Weight Glands (lbs)	Weight (w/ Acc.)	Pressure Rating (psi)	Pipe OD
3	TLD-3	2	4	6.5	10.5	350	3.96
4	TLD-4	2	4	7.1	11.8	350	4.80
6	TLD-6	3	6	11.2	17.8	350	6.90
8	TLD-8	3	6	13.1	20.3	350	9.05
10	TLD-10	6	8	26.0	32.5	350	11.10
12	TLD-12	8	8	31.5	40.4	350	13.20
14	TLD-14	10	10	43.3	53.6	350	15.30
16	TLD-16	12	12	54.1	66.3	350	17.40
18	TLD-18	12	12	59.8	72.2	250	19.50
20	TLD-20	14	14	69.8	83.8	250	21.60
24	TLD-24	16	16	90.4	106.9	250	25.80
30	TLD-30	20	20	248	290	250	32.00
36	TLD-36	24	24	277	327	250	38.30
42	TLD-42	28	28	448	512	250	44.50
48	TLD-48	32	32	519	597	250	50.80

# TUF GRIP™

## For PVC Pipe

*"A Proven Third Generation Mechanical Joint Restraint"*

TufGrip™ PVC  
(TLP)

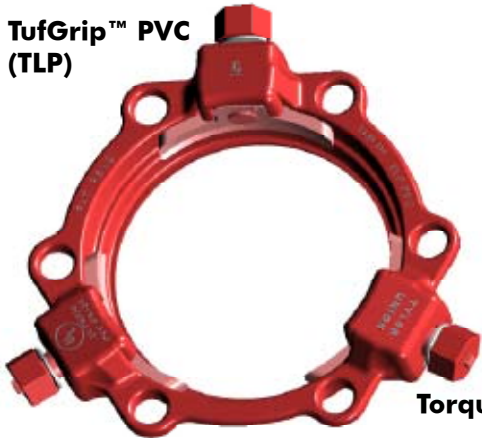

Torque Nut



Tyler Union's TUF Grip restraints represent the culmination of 20 years of engineering and testing. As a 3rd generation restraint, TUF Grip is the best available technology in the Waterworks market for use in restraining PVC pipe.



Designed by Harold Kennedy & Associates, Inc.

ISO 9001-2000  
Registered



UL Listed &  
FM Approved

### TUF GRIP TLP • PVC PIPE RESTRAINT

#### SPECIFICATIONS

- Designed and proven to restrain PVC Pipe 3 inches through 36 inches in diameter.
- UL Listed and FM approved for 4 inch thru 12 inch applications
- Restrains 3 inch thru 12 inch IPS PVC pipe with no modification to the restraint
- TUF Grip deflection specification is 5° deflection through 12 inch and 3° deflection for 14 inch to 36 inch
- Cast with tested and traceable ASTM A536 compliant 65-45-12 ductile iron.
- Restraint Gland and all components are rated and proven for a 2:1 safety factor based on pipe pressure rating
- Conforms to applicable requirements of C110/A21.10, C111.A21.11, C153/A21.53, and ASTM F1674-5
- Restrains any class of PVC pipe conforming to AWWA C900/905

#### FEATURES • ADVANTAGES

- Proven Restraint technology utilizing fewer wedges in frequently applied diameters
- Fewer wedges equate to less time in the trench and greatly reduced project cost
- TUF Grip PVC restraints are color coded red for easy recognition
- Single tooth contoured wedges reduce pipe wall stress and eliminate point loading of the pipe
- PVC wedge design maintains pipe hoop strength integrity
- TUF Grip restraints utilize curved wedges to prevent flattening of the pipe
- Collar bolts and wedges pivot providing for stronger engagement of pipe at lower torque (45 to 60 ft. pounds)
- Wedge Torque nuts twist off within a designed torque range so specialized tools are not required for installation
- TUF Grip restraints eliminate the need for cumbersome Thrust blocks and Tie-Rods
- Larger inside diameter of the gland provides for easier installation on out of round pipe
- Can be used on HDPE and C909 pipe, contact Tyler Union Technical support
- Suitable for Potable and Wastewater applications
- Allows for disassembly just like a standard mechanical joint.
- Designed by Harold Kennedy one of the foremost restraint engineers in the industry today

## PVC Pipe Restraint

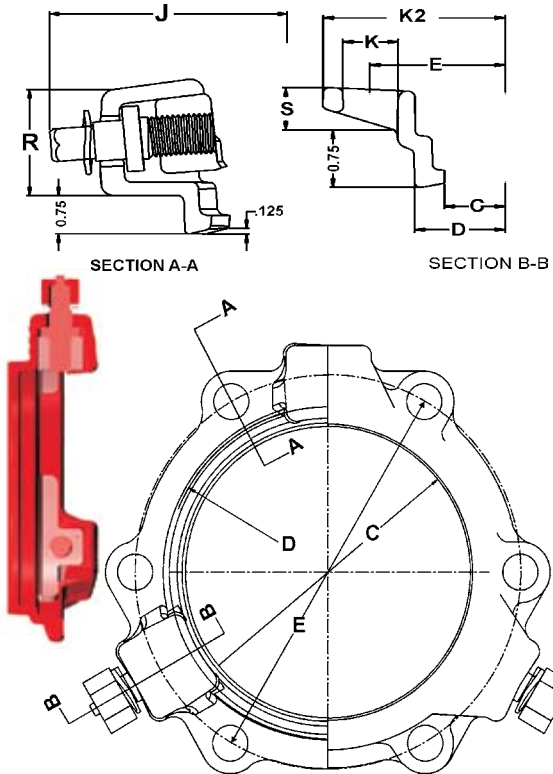

TUF Grip<sup>TM</sup> MJ Restraint Dimensions

Size (inches)	C	D	E	F	J	K	R	S
3	4.08	4.88	6.19	7.67	9.82	3/4	2.20	0.86
4	4.93	5.92	7.50	8.98	10.67	7/8	2.20	0.73
6	7.03	8.02	9.50	10.98	12.77	7/8	2.24	0.82
8	9.18	10.17	11.75	13.23	14.92	7/8	2.28	0.82
10	11.23	12.22	14.00	15.70	16.97	7/8	2.37	0.93
12	13.33	14.32	16.25	17.95	19.07	7/8	2.40	0.93
14	15.44	16.40	18.75	20.43	21.18	7/8	2.57	0.91
16	17.54	18.50	21.00	22.88	23.28	7/8	2.57	1.05
18	19.64	20.60	23.25	25.43	25.38	7/8	2.57	1.05
20	21.74	22.70	25.50	27.50	27.48	7/8	2.66	1.15
24	25.94	26.90	30.00	32.00	31.68	7/8	2.72	1.35
30	32.18	33.30	36.88	39.42	39.78	1-1/8	3.86	1.53
36	38.48	39.60	43.75	46.29	46.08	1-1/8	3.86	1.53

## PVC TUF Grip<sup>TM</sup> Application Chart

Size (inches)	Part Number	Wedge Quantity	T-Bolt Quantity	Weight (lbs.)	Weight (w/Acc.)	Pressure Rating (psi)	Pipe OD
3	TLP-3	2	4	7.0	11.0	305	3.50
4	TLP-4	2	4	8.3	12.2	305	4.50-4.80
6	TLP-6	3	6	12.4	18.3	305	6.63-6.90
8	TLP-8	3	6	14.9	20.8	305	8.63-9.05
10	TLP-10	6	8	25.7	33.4	305	10.75-11.10
12	TLP-12	8	8	34.1	42.0	305	12.75-13.20
14	TLP-14	10	10	45.1	55.4	235	15.30
16	TLP-16	12	12	56.2	68.4	235	17.40
18	TLP-18	12	12	62.4	74.8	235	19.50
20	TLP-20	14	14	72.9	86.9	235	21.60
24	TLP-24	16	16	93.2	109.8	235	25.80
30	TLP-30	20	20	251	293	150	32.00
36	TLP-36	24	24	281	331	125	38.30