

28U-B — ANSI/AWWA C110/A21.10 C110 FLANGE JOINT CLASS 250 PRODUCT

Revised 02/2025 (Current revisions for the noted Standards apply)

SIZES:	2"–48"
STANDARDS:	ANSI/AWWA C110/A21.10, NFPA 13/24, ASME B16.1.
MATERIAL:	Cast of ASTM A536 qualified ductile iron. Date code is cast on and required for traceability.
PRESSURE RATING:	*Flanged fittings *2"–48" rated at 250 psi. *Note: With rubber annular ring flange gasket, 2"–24" flanged fittings can be rated at 350 psi.
DEFLECTION:	Deflection is not recommended for flange joint due to the rigidity of the joint.
NSF-61 & NSF372:	Meets all requirements, including Annex G, Tyler Union's Underwriters Laboratory listing MH16439.
COATING:	Asphaltic or Primer per ANSI/AWWA C104/A21.4. Standard primer is Tnemec Pota Pox N140-1211. Contact Tyler Union for additional coating options.
CEMENT LINING:	Per ANSI/AWWA C104/A21.4, with double cement lining available upon request.
EPOXY COATING:	Fusion-bonded epoxy per ANSI/AWWA C116/A21.16. Additional coatings available upon request.
BARE FITTINGS:	Available upon request.
FLANGES:	ANSI Class 250 per ASME B16.1 and ANSI/AWWA C111/A21.11. Bolt holes shall straddle the center line. NOTE: Class 250 ASME B16.1 are not compatible with Class 125 Flanges. NOTE: Class 250 ASME B16.1 fittings are available upon request.
FASTENERS:	High-strength low-alloy weathering steel per ANSI/AWWA C111/A21.11 and ASTM A242.
INSTALLATION:	Install per AWWA C600/C651 using pipe conforming to ANSI/AWWA C151/A21.51.

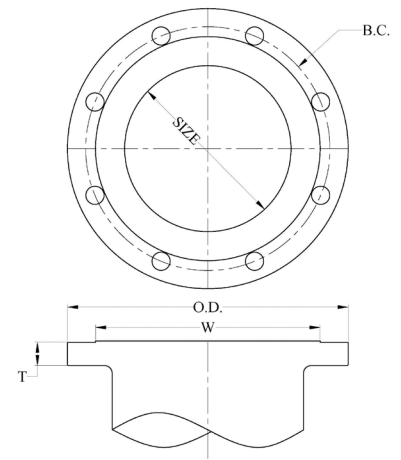

CLASS 250 FLANGE DETAILS IN INCHES								
Size (In.)	Diameter DI Pipe	Flange O.D.	W (Raised Face)	B.C. Diameter	Flange Thickness T	Bolt Hole Diameter	Bolt Size	Qty. Bolts
2	2.51	6.50	4.19	5.00	0.88	0.75	5/8 x 3	8
3	3.96	8.25	5.69	6.62	1.12	0.875	3/4 x 3-1/2	8
4	4.80	10.00	6.94	7.88	1.25	0.875	3/4x4	8
6	6.90	12.50	9.69	10.62	1.44	0.875	3/4 x 4	12
8	9.05	15.00	11.94	13.00	1.62	1.000	7/8 x4-1/2	12
10	11.10	17.50	14.06	15.25	1.88	1.125	1.0x5-1/2	16
12	13.20	20.50	16.44	17.75	2.00	1.250	1-1/8 x5-1/2	16
14	15.30	23.00	18.94	20.25	2.12	1.250	1-1/8 x 6	20
16	17.40	25.50	21.06	22.50	2.25	1.375	1-1/4x 6-1/2	20
18	19.50	28.00	23.31	24.75	2.38	1.375	1-1/4 x 6-1/2	24
20	21.60	30.50	25.56	27.00	2.50	1.375	1-1/4 x7	24
24	25.80	36.00	30.31	32.00	2.75	1.625	1-1/2 x 7-1/2	24
30	32.00	43.00	37.19	39.25	3.00	2.000	1-3/4 x 8-1/2	28
36	38.30	50.00	43.69	46.00	3.38	2.250	2x9-1/2	32
42	44.50	57.00	50.44	52.75	3.69	2.250	2x10	36
48	50.80	65.00	58.44	60.75	4.00	2.250	2x11	40