



TYLER UNION®

Quality Waterworks Products



WATERWORKS CATALOG

PC-2025, March 2025
www.tylerunion.com



Product warranty with terms and conditions of sale located at www.McWane.com.

ANSI/AWWA C153 Mechanical Joint Fittings	1
Bends	2–4
Tees	5–7
Wyes	7
Offsets (MJxMJ) or (MJxPE)	7
Solid & Tapped Plugs & Caps	8
Tapping Sleeves	8
Solid Sleeves	8
Reducers	9
Adapters	10
Glands	11
Dual Purpose Cutting-In Sleeves	12
MJ Hydrant Bury	12
ANSI/AWWA C110 Mechanical Joint Fittings	13
Bends	14–15
Offsets	15
Tees	16–17
Reducers	18
Solid Sleeves	19
MJxFE Adapters	19
Plugs	20
Caps	20
Wyes/Laterals	21
MJ Glands	21
ANSI/AWWA C153 Push-On Joint Fittings	22
Bends	23–24
Tees	25–26
Wyes	26
Reducers	27
Caps and Plugs	27
Adapters	27
UT Hydrant Bury	27
ANSI/AWWA C110 Class 125 Flange Fittings	28
Bends	29–31
Tees	31–34
Reducers	35
Wyes/Laterals	36
Flange By Flare Pieces	36
Flanges	37
Flange Sludge Shoes	37
Adapter Flanges	37
Tap Locations	38
ANSI/AWWA C110 Class 250 Flange Fittings	39
Bends	40–41
Tees	42
Reducers	43
Wyes/Laterals	44
Flange By Flare Pieces	45
Municipal Castings & Valve and Service Boxes	46
6500 Screw Type Valve Boxes	46
6850 2 Piece Screw Type Valve Boxes	47
6855 2 Piece Screw Type Valve Boxes	48
6860 3 Piece Screw Type Valve Boxes	49–50
Valve Box Lids	51
Valve Box Risers and Specialty Tops	52
Meter Box Rings and Covers	53

C153 DUCTILE IRON COMPACT FITTINGS

SAMPLE SPECIFICATIONS

(Current ANSI/AWWA revisions apply)

Mechanical joint water main fittings with accessories 2" through 64" shall be manufactured from ductile iron in accordance with and meet all applicable terms and provisions of standards ANSI/AWWA C153/A21.53 and ANSI/AWWA C111/A21.11. Ductile iron mechanical joint fittings 2" through 24" shall be rated for 350 psi working pressure. Ductile iron 30" through 48" shall be rated for 250 psi working pressure. Flanged ductile iron fittings in 4" through 24" may be rated for 350 psi (2,413 kPa) with the use of special (annular ring or comparable) gaskets. All coated and lined fittings meet requirements of NSF-61, NSF-372 and Annex G.

NOTE: EXCEPTIONS: Mechanical joint fittings with flanged branches are rated for water pressure of 250 psi.

NOTE: Wyes over 12" are not pressure rated. Contact manufacturer for rating in your application.

NOTE: Fittings are cement lined and seal coated in accordance with ANSI/AWWA C104/A21.4. Fittings are available double cement lined, bare or epoxy coated upon request. Epoxy coating per ANSI/AWWA C116.

NOTE: Installation per AWWA C600 and AWWA C651, current revision.

Nominal Joint Dimensions in Inches														
Size	A	B	C	D	F	ø	X	J	K1	K2	L	M	O	S
2	2.51	2.50	3.50	3.60	2.61	28°	3/4	4.75	6.19	6.89	0.58	0.62	0.31	0.36
3	3.96	2.50	4.84	4.94	4.06	28°	3/4	6.19	7.62	7.69	0.58	0.62	0.31	0.39
4	4.80	2.50	5.92	6.02	4.90	28°	7/8	7.50	9.06	9.12	0.60	0.75	0.31	0.39
6	6.90	2.50	8.02	8.12	7.00	28°	7/8	9.50	11.06	11.12	0.63	0.88	0.31	0.43
8	9.05	2.50	10.17	10.27	9.15	28°	7/8	11.75	13.31	13.37	0.66	1.00	0.31	0.45
10	11.10	2.50	12.22	12.34	11.20	28°	7/8	14.00	15.62	15.62	0.70	1.00	0.31	0.47
12	13.20	2.50	14.32	14.44	13.30	28°	7/8	16.25	17.88	17.88	0.73	1.00	0.31	0.49
14	15.30	3.50	16.40	16.54	15.44	28°	7/8	18.75	20.25	20.25	0.79	1.25	0.31	0.55
16	17.40	3.50	18.50	18.64	17.54	28°	7/8	21.00	22.50	22.50	0.85	1.31	0.31	0.58
18	19.50	3.50	20.60	20.74	19.64	28°	7/8	23.25	24.75	24.75	1.00	1.38	0.31	0.68
20	21.60	3.50	22.70	22.84	21.74	28°	7/8	25.50	27.00	27.00	1.02	1.44	0.31	0.69
24	25.80	3.50	26.90	27.04	25.94	28°	7/8	30.00	31.50	31.50	1.02	1.56	0.31	0.75
30	32.00	4.00	33.29	33.46	32.17	20°	1 1/8	36.88	39.12	39.12	1.31	2.00	0.38	0.82
36	38.30	4.00	39.59	39.76	38.47	20°	1 1/8	43.75	46.00	46.00	1.45	2.00	0.38	1.00
42	44.50	4.00	45.79	45.96	44.67	20°	1 3/8	50.62	53.12	53.12	1.45	2.00	0.38	1.35
48	50.80	4.00	52.09	52.26	50.97	20°	1 3/8	57.50	60.00	60.00	1.45	2.00	0.38	1.35
54	57.56	4.00	58.82	59.02	57.73	20°	1 3/8	63.20	65.70	65.70	1.55	2.00	0.38	1.45
60	61.61	4.00	62.87	63.07	61.78	20°	1 3/8	67.72	70.22	70.22	1.75	2.00	0.38	1.50
64	65.67	4.00	66.96	67.13	65.84	20°	1 3/8	71.86	74.36	74.36	1.75	2.00	0.38	1.50

NOTE: For projects where product weights, specifications or dimensions are critical, advise upon order placement

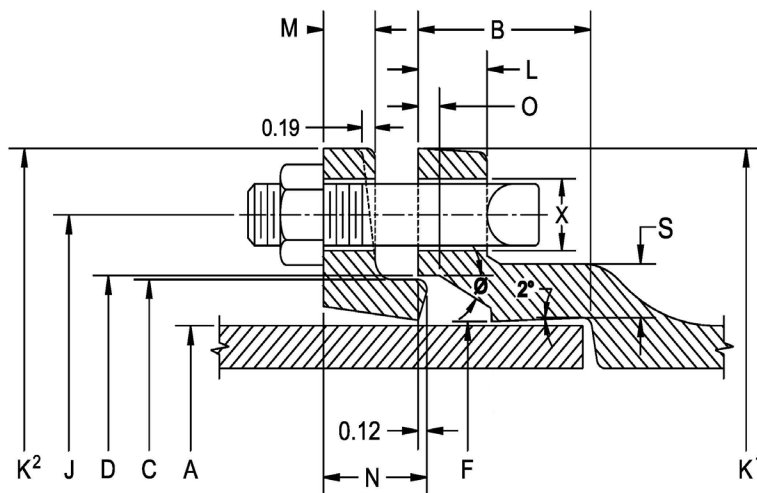

ANSI/AWWA
C153 Mechanical Joint Fittings

C153 DUCTILE IRON COMPACT FITTINGS

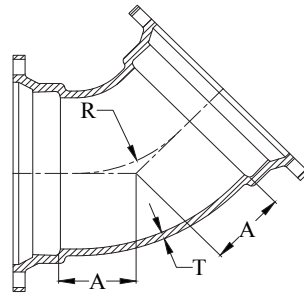
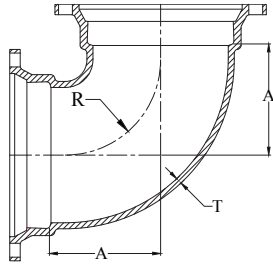

90° Bends (1/4)								45° Bends (1/8)					
Domestic				Import				Domestic			Import		
Size	T	A	R	Weight	T	A	Weight	A	R	Weight	A	Weight	
3	0.34	3.50	2.50	26	0.33	3.50	19	2.00	2.41	17	1.50	16	
4	0.35	4.00	3.00	26	0.34	4.00	24	2.50	3.56	22	2.00	22	
6	0.37	6.00	5.00	45	0.36	5.00	39	3.00	7.25	38	3.00	32	
8	0.39	7.00	6.00	62	0.38	6.50	57	4.00	8.44	51	3.50	46	
10	0.41	7.50	6.50	89	0.40	7.50	89	5.00	10.88	75	4.50	70	
12	0.43	9.00	8.00	114	0.42	9.00	108	5.50	13.25	108	5.50	101	
14	0.51	12.00	11.50	210	0.47	11.50	210	5.50	12.06	156	5.00	160	
16	0.52	13.00	12.50	268	0.50	12.50	264	5.50	10.42	191	5.50	202	
18	0.59	15.50	14.00	375	0.54	14.00	335	6.00	11.18	252	6.00	250	
20	0.60	17.00	15.50	443	0.57	15.00	400	7.00	13.59	303	7.00	305	
24	0.62	17.00	15.50	663	0.61	16.75	565	7.50	14.89	398	7.50	405	
30	0.66	21.50	19.00	1005	0.66	21.50	930	10.50	9.31	850	10.50	780	
36	0.74	24.50	22.00	1540	0.74	24.50	1450	11.50	21.73	1135	11.50	1135	
42	0.82	29.25	26.70	2380	0.82	29.25	2205	14.00	27.76	1675	14.00	1610	
48	0.90	33.25	30.80	3084	0.90	33.25	2990	15.00	30.17	2196	15.00	2090	

NOTE: Other sizes available, contact Tyler Union for information.

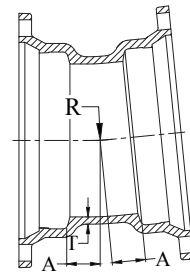
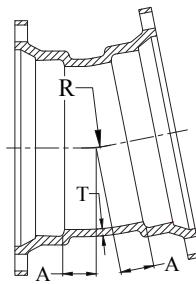
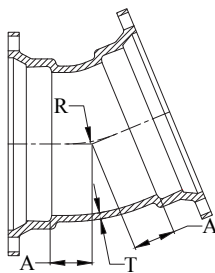

22½° Bends (1/16)						11¼° Bends (1/32)						5 - 8/8 Bends (1/64) MJ x MJ					
Domestic			Import			Domestic			Import			Import					
Size	A	R	Weight	A	Weight	A	R	Weight	A	Weight	A	R	Weight				
3	1.50	2.51	16	1.00	15	1.25	2.53	15	1.00	14	1.25	5.08	16				
4	1.75	3.81	21	1.50	18	1.50	5.12	21	1.30	16	1.50	7.61	18				
6	2.25	6.35	31	2.00	31	1.50	5.12	30	1.50	30	1.50	10.15	29				
8	2.85	11.80	44	2.50	46	2.06	15.80	43	1.80	42	1.75	12.69	45				
10	3.35	14.35	67	3.00	64	2.32	18.36	58	2.00	58	2.00	15.23	59				
12	3.86	16.90	81	3.50	80	2.56	20.90	68	2.30	67	2.30	17.77	82				
14	3.93	17.25	139	3.75	136	2.59	21.25	123	2.50	93	2.50	20.31	136				
16	3.98	17.50	172	3.75	172	2.62	21.50	145	2.50	148	2.50	20.31	157				
18	4.50	15.11	275	4.50	255	3.00	16.52	205	3.00	205	3.00	25.38	283				
20	4.50	15.07	341	4.50	310	3.00	15.23	245	3.00	245	3.00	25.38	374				
24	4.50	15.51	333	4.50	366	3.00	16.10	304	3.00	315	3.00	25.38	487				
30	6.75	21.36	670	6.75	665	4.75	22.84	551	4.80	600	3.75	32.97	600				
36	7.75	26.39	978	7.75	960	5.00	25.38	870	5.00	820	4.00	34.55	820				
42	9.00	32.68	1352	9.00	1350	6.00	35.54	1163	6.00	1180	5.00	42.71	1180				
48	10.00	27.70	1757	10.00	1760	6.50	40.61	1474	6.50	1475	5.50	47.35	1475				

NOTE: Contact Tyler Union for details on 54" through 64". **NOTE:** For projects where product weights, specifications or dimensions are critical, advise upon order placement.

C153 DUCTILE IRON COMPACT FITTINGS

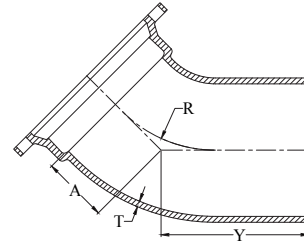
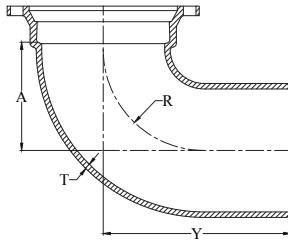

90° Bend MJ x PE (1/4)										45° Bend MJ x PE (1/8)						
Domestic						Import				Domestic				Import		
Size	T	A	Y	R	Weight	T	A	Y	Weight	A	Y	R	Weight	A	Y	Weight
3	0.34	3.50	9.00	2.50	17	0.33	3.25	8.50	16	2.00	7.50	2.41	17	1.50	7.00	13
4	0.35	4.00	9.50	3.00	26	0.34	4.00	9.50	22	2.50	8.00	3.56	21	2.00	7.50	19
6	0.37	6.00	11.50	5.00	41	0.36	5.00	11.50	41	3.00	8.50	5.49	35	3.00	8.50	34
8	0.39	7.50	13.00	7.00	64	0.38	6.50	12.50	58	4.00	9.50	8.44	54	3.50	9.00	49
10	0.41	9.50	15.00	9.00	89	0.40	7.50	13.00	83	5.00	10.50	10.88	69	4.50	10.00	69
12	0.43	9.00	14.40	6.00	121	0.42	9.00	14.50	114	6.00	11.50	13.25	94	5.50	11.00	93
14	0.51	12.00	20.00	11.50	221	0.47	11.50	19.50	197	5.50	13.40	10.85	170	5.00	13.00	146
16	0.52	13.00	21.00	12.50	261	0.50	12.50	20.50	248	6.00	14.00	13.25	188	5.50	13.50	184
18	0.59	15.50	23.50	14.00	—	0.54	14.00	22.00	360	6.00	14.00	11.18	—	6.00	11.18	240
20	0.60	15.00	23.00	13.50	400	0.57	15.00	22.50	390	7.00	15.30	13.97	290	7.00	14.00	290
24	0.62	17.00	25.00	15.50	600	0.61	17.00	25.00	575	7.50	16.60	14.69	410	7.50	14.50	390
30	0.68	21.50	30.50	19.00	865	0.66	21.50	30.50	865	10.50	19.50	19.31	715	10.50	19.50	715

Tyler Union does not recommend the use of wedge action restraints on plain end fittings.

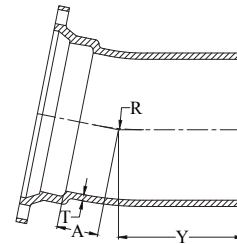
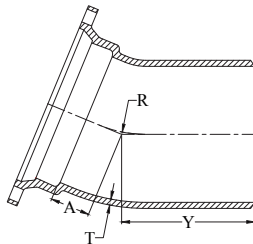

22 1/2° Bend MJ x PE (1/16)								11 1/4° Bend MJ x PE (1/32)						
Domestic				Import				Domestic				Import		
Size	A	Y	R	Weight	A	Y	Weight	A	Y	R	Weight	A	Y	Weight
3	1.50	7.00	2.51	15	1.00	6.50	12	1.25	6.75	7.62	15	1.00	6.50	12
4	1.75	7.25	3.81	17	1.50	7.00	18	1.50	7.00	5.12	17	1.25	6.25	17
6	2.25	7.75	6.35	28	2.00	7.50	29	1.50	7.00	5.12	29	1.50	7.00	27
8	2.84	8.34	11.80	44	2.50	8.00	43	2.05	7.55	15.80	38	1.75	7.25	39
10	3.35	8.85	14.35	64	3.00	8.50	61	2.31	7.81	18.36	52	2.00	7.50	52
12	3.50	9.00	12.70	77	3.50	9.00	79	2.56	8.06	20.90	86	2.25	7.75	69
14	3.93	11.93	17.25	121	3.75	11.25	133	2.59	10.59	21.25	134	2.50	10.50	118
16	3.98	11.98	17.50	167	3.75	11.75	166	2.62	10.62	21.50	161	2.50	10.50	136
18	4.50	12.50	15.11	—	4.50	12.50	248	3.00	11.00	16.52	—	3.00	11.00	248
20	7.00	14.00	35.19	290	7.00	14.00	300	7.00	14.00	21.07	290	7.00	14.00	300
24	9.00	17.66	37.69	345	7.50	14.50	395	9.00	26.12	12.00	475	7.50	14.50	400
30	6.75	15.75	21.36	600	6.75	15.75	600	4.75	13.75	22.84	535	4.75	13.75	535

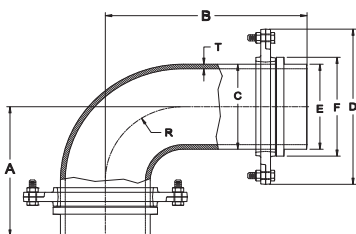

90° Swivel x Swivel Hydrant Ell									
Size	T	A	B	C	D	E	F	R	**Weight
6	0.37	10.50	15.50	6.90	11.20	6.81	7.98	6.00	68

NOTE: **Weight includes two swivel glands.

C153 DUCTILE IRON COMPACT FITTINGS

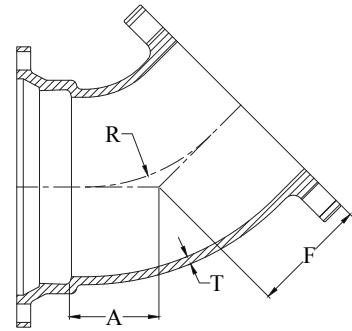
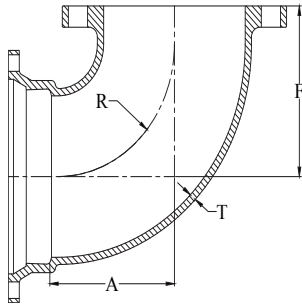

90° Bend MJ x FE (1/4)										45° Bends MJ x FE (1/8)						
Domestic					Import					Domestic				Import		
Size	T	A	R	F	Weight	T	A	F	Weight	A	F	R	Weight	A	F	Weight
3	0.34	3.50	2.50	5.50	21	0.34	4.00	5.50	21	-	-	-	-	-	-	-
4	0.35	4.00	3.00	6.50	33	0.35	4.50	6.50	36	2.50	4.00	3.56	34	2.50	4.00	24
6	0.37	6.00	5.00	8.00	49	0.37	6.00	8.00	51	3.00	5.00	5.49	39	3.25	5.00	37
8	0.39	7.50	7.00	9.00	67	0.39	7.00	9.00	83	4.25	5.50	7.93	54	3.75	5.50	71
10	0.41	9.50	9.00	11.00	106	0.41	7.50	11.00	109	5.00	6.50	9.76	84	4.75	6.50	103
12	0.43	10.50	10.00	12.00	148	0.43	9.25	12.00	150	6.00	7.50	12.19	112	5.75	7.50	151
14	0.51	12.00	11.50	14.00	217	0.51	11.50	14.00	275	5.50	8.50	10.85	181	5.00	7.50	207
16	0.52	13.00	12.50	15.00	297	0.52	12.50	15.00	335	5.50	9.00	10.42	218	5.75	8.00	311
18	0.59	15.50	14.00	19.00	-	0.54	14.50	16.50	-	6.50	10.00	12.36	-	6.50	8.50	-
20	0.60	15.00	23.00	18.50	-	0.57	15.00	18.00	-	7.00	10.50	13.59	-	7.50	9.50	-
24	0.62	17.00	25.00	20.50	-	0.62	16.75	22.00	618	7.50	11.00	14.89	-	8.00	11.00	575
30	0.68	21.50	30.50	26.00	-	0.68	21.50	26.00	1014	10.50	15.00	9.31	-	10.50	15.00	794

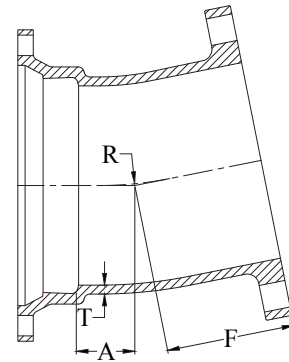
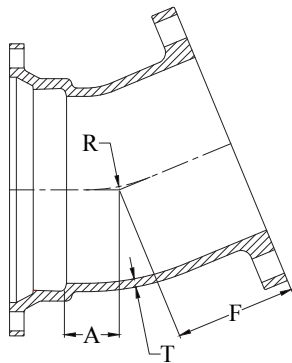

22 1/2° Bend MJ x FE (1/16)								11 1/4° Bends MJ x FE (1/32)						
Domestic				Import				Domestic				Import		
Size	A	F	R	Weight	A	F	Weight	A	F	R	Weight	A	F	Weight
3	-	-	-	-	-	-	-	-	-	-	-	-	-	-
4	1.75	4.00	3.81	21	1.50	7.00	32	1.50	7.00	5.12	20	1.50	4.00	28
6	2.25	5.00	5.35	32	2.00	7.50	41	1.50	7.00	5.12	29	1.75	5.00	40
8	2.84	5.50	7.62	46	2.50	8.00	64	2.05	7.55	15.80	42	2.00	5.50	53
10	3.35	6.50	10.16	78	3.00	8.50	92	2.31	7.81	18.36	58	2.25	6.50	88
12	3.50	7.50	12.70	106	3.50	9.00	132	2.56	8.06	20.90	85	2.50	7.50	114
14	-	-	-	-	-	-	-	-	-	-	-	-	-	-
16	-	-	-	-	-	-	-	-	-	-	-	-	-	-
18	4.50	15.11	8.00	-	-	-	-	3.00	6.50	16.52	-	-	-	-
20	4.50	15.07	8.00	-	-	-	-	3.00	6.50	15.23	-	-	-	-
24	4.50	15.51	8.00	-	-	-	-	3.00	6.50	16.10	-	-	-	-
30	6.75	21.36	11.25	-	-	-	-	4.75	7.25	22.84	-	-	-	-

C153 DUCTILE IRON COMPACT FITTINGS

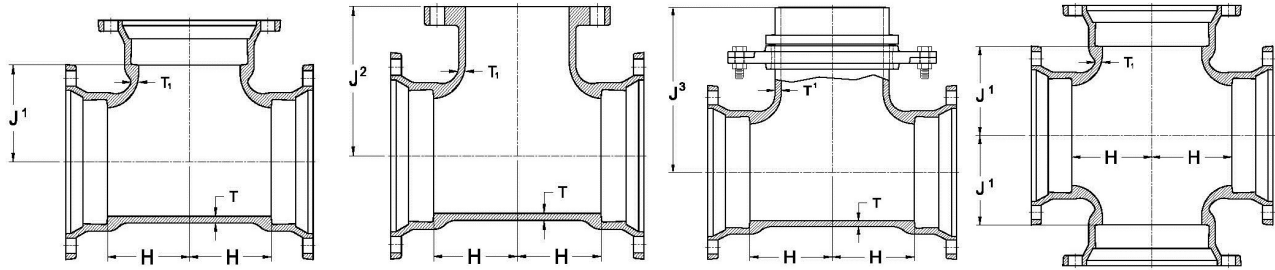

MJ Tee							MJxFE Tee				MJxSwivel Tee				Cross			
Domestic							Weight				Import				Weight			
Size	T	T1	H	J1	J2	J3	MJ	MJ x FE	†MJ x S	Cross	T	T1	H	J1	MJ	Cross		
3	0.34	0.34	3.50	3.50	5.50	—	26	29	—	31	0.33	0.33	3.00	3.00	28	35		
4x3	0.35	0.34	3.50	4.00	6.50	—	35	34	—	39	0.34	0.33	3.50	4.00	30	34		
4	0.35	0.35	4.00	4.00	6.50	—	37	39	—	45	0.34	0.34	4.00	4.00	32	40		
6x3	0.37	0.34	4.00	4.00	6.50	—	51	54	—	—	0.36	0.33	3.50	5.00	42	—		
6x4	0.37	0.35	5.00	6.00	8.00	—	52	57	—	62	0.36	0.34	4.00	5.00	46	57		
6	0.37	0.37	6.00	6.00	8.00	10.50	62	69	61	72	0.36	0.36	5.00	5.00	56	75		
8x3	0.39	0.34	4.00	6.50	9.00	—	56	—	—	—	—	—	—	—	—	—		
8x4	0.39	0.35	5.00	6.50	9.00	—	68	82	—	84	0.38	0.34	4.00	6.50	60	68		
8x6	0.39	0.37	6.00	7.00	9.00	11.50	79	87	96	98	0.38	0.36	5.00	6.50	72	74		
8	0.39	0.39	6.50	6.50	9.00	11.50	89	101	116	112	0.38	0.38	0.38	6.50	86	105		
10x3	0.41	0.34	4.00	7.50	11.00	—	80	—	—	—	—	—	—	—	—	—		
10x4	0.41	0.35	4.50	7.50	11.00	—	82	92	—	98	0.40	0.34	4.00	7.50	78	84		
10x6	0.41	0.37	5.50	7.50	11.00	13.00	99	116	114	121	0.40	0.36	5.00	7.50	90	119		
10x8	0.41	0.39	6.50	7.50	11.00	13.00	116	128	138	135	0.40	0.38	6.50	7.50	105	124		
10	0.41	0.41	7.50	7.50	11.00	—	132	144	—	156	0.40	0.40	7.50	7.50	120	145		
12x3	0.43	0.34	4.00	8.75	12.00	—	99	—	—	—	—	—	—	—	—	—		
12x4	0.43	0.35	4.00	9.00	12.00	—	108	118	—	119	0.42	0.34	4.00	8.75	94	119		
12x6	0.43	0.37	5.00	9.00	12.00	14.25	119	133	132	138	0.42	0.34	4.00	8.75	110	126		
12x8	0.43	0.39	6.50	9.00	12.00	14.25	126	146	149	149	0.42	0.38	6.50	8.75	125	149		
12x10	0.43	0.41	7.50	8.75	12.00	—	159	174	—	187	0.42	0.40	7.50	8.75	140	179		
12	0.43	0.43	8.75	8.75	12.00	—	171	198	—	202	0.42	0.42	8.75	8.75	160	213		
14x6	0.51	0.44	6.50	10.50	14.00	16.00	183	205	211	210	0.47	0.36	6.50	10.50	182	200		
14x8	0.51	0.45	7.50	10.50	14.00	—	211	—	—	231	0.47	0.38	7.50	10.50	206	228		
14x10	0.51	0.46	8.50	10.50	14.00	—	229	244	—	255	0.47	0.40	8.50	10.50	228	—		
14x12	0.51	0.47	9.50	10.50	14.00	—	245	284	—	269	0.47	0.42	9.50	10.50	234	—		
14	0.51	0.51	10.50	10.50	14.00	—	281	291	—	299	0.47	0.47	10.50	10.50	280	299		
16x6	0.52	0.45	6.50	11.50	14.00	16.00	222	230	243	250	0.50	0.36	6.50	11.50	228	240		
16x8	0.52	0.46	7.50	11.50	15.00	—	245	248	—	264	0.50	0.38	7.50	11.50	248	385		
16x10	0.52	0.47	8.50	11.50	15.00	—	265	287	—	286	0.50	0.40	8.50	11.50	264	—		
16x12	0.52	0.48	9.50	11.50	15.00	—	277	312	—	312	0.50	0.42	9.50	11.50	280	—		
16x14	0.52	0.51	10.50	11.50	15.00	—	317	348	—	—	0.50	0.47	10.50	11.50	316	—		
16	0.52	0.52	11.50	11.50	15.00	—	337	324	—	451	0.50	0.50	11.50	11.50	322	—		
18x6	0.59	0.44	6.50	14.50	15.50	18.00	275	261	279	—	0.54	0.36	6.50	12.50	275	—		
18x8	0.59	0.45	7.50	14.50	14.50	—	280	351	—	—	0.54	0.38	7.50	12.50	295	—		
18x10	0.59	0.47	8.50	12.50	—	—	286	—	—	—	0.54	0.40	8.50	12.50	315	—		
18x12	0.59	0.49	9.50	12.50	—	—	372	—	—	—	0.54	0.42	9.50	12.50	335	348		
18x14	0.59	0.56	10.50	12.50	—	—	415	—	—	—	0.54	0.47	10.50	12.50	380	—		
18x16	0.59	0.57	11.50	12.50	—	—	445	—	—	—	0.54	0.50	11.50	12.50	405	—		
18	0.59	0.59	13.00	12.50	—	—	490	—	—	—	0.54	0.54	12.50	12.50	435	348		
20x6	0.60	0.44	7.00	14.00	16.00	19.50	335	362	358	—	0.57	0.36	6.50	14.00	315	—		
20x8	0.60	0.45	8.00	14.00	—	—	390	—	—	—	0.57	0.38	8.00	14.00	345	379		
20x10	0.60	0.47	9.00	14.00	—	—	417	—	—	—	0.57	0.40	9.00	14.00	370	—		
20x12	0.60	0.49	10.00	14.00	—	—	460	—	—	—	0.57	0.42	10.00	14.00	395	413		
20x14	0.60	0.56	11.00	14.00	—	—	475	—	—	—	0.57	0.47	11.00	14.00	440	—		
20x16	0.60	0.57	12.00	14.00	—	—	530	—	—	—	0.57	0.50	12.00	14.00	465	—		
20x18	0.60	0.59	13.00	14.00	—	—	560	—	—	—	0.57	0.54	13.00	14.00	505	—		
20	0.60	0.60	14.00	14.00	—	—	605	—	—	—	0.57	0.57	14.00	14.00	535	—		

NOTE: Contact TU Inside Sales representative for MJ Crosses larger than 16". †MJxSwl Weights include swivel gland.

NOTE: Other sizes available, contact Tyler Union for information.

C153 DUCTILE IRON COMPACT FITTINGS

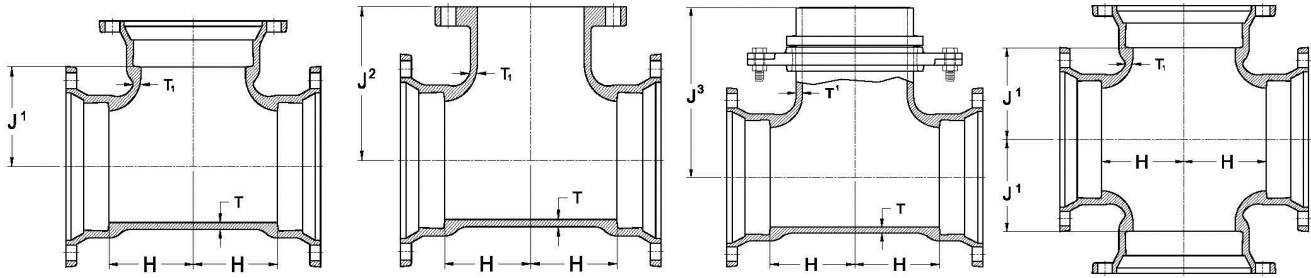

MJ Tee				MJxFE Tee			MJxSwivel Tee				Cross				
Domestic				Weight			Import				Weight				
Size	T	T1	*H	*J1	*J2	*J3	MJ	MJ x FE	†MJ x S	T	T1	H	J1	MJ	Cross
24x6	0.62	0.44	7.00	16.00	19.00	21.50	465	451	457	0.61	0.36	7.00	16.00	415	—
24x8	0.62	0.45	8.00	16.00	—	—	475	—	—	0.61	0.38	8.00	16.00	445	481
24x10	0.62	0.47	9.00	16.00	—	—	516	—	—	0.61	0.40	9.00	16.00	470	—
24x12	0.62	0.49	10.00	16.00	—	—	549	580	—	0.61	0.42	10.00	16.00	500	529
24x14	0.62	0.56	11.00	16.00	—	—	585	—	—	0.61	0.47	11.00	16.00	550	—
24x16	0.62	0.57	12.00	16.00	—	—	625	744	—	0.61	0.50	12.00	16.00	580	576
24x18	0.62	0.59	13.00	16.00	—	—	675	—	—	0.61	0.54	13.00	16.00	625	—
24x20	0.62	0.60	14.00	16.00	—	—	740	—	—	0.61	0.57	14.00	16.00	660	1589
24	0.62	0.62	17.00	17.00	—	—	844	—	—	0.61	0.61	16.00	16.00	720	—
30x6	0.66	0.36	8.00	20.00	—	—	700	—	—	0.66	0.36	8.00	20.00	685	—
30x8	0.66	0.38	8.00	20.00	—	—	739	—	—	0.66	0.38	8.50	20.00	739	—
30x12	0.66	0.42	10.00	20.00	—	—	739	—	—	0.66	0.42	10.00	20.00	830	882
30x16	0.66	0.50	12.50	20.00	—	—	959	—	—	0.66	0.50	12.50	20.00	959	—
30x18	0.66	0.52	13.00	20.00	—	—	975	—	—	0.66	0.54	13.00	20.00	1039	—
30x20	0.66	0.57	15.00	20.00	—	—	995	—	—	0.66	0.57	15.00	20.00	995	—
30x24	0.66	0.61	16.00	20.00	—	—	1160	—	—	0.66	0.61	16.00	20.00	1060	1246
30	0.66	0.66	20.00	20.00	—	—	1323	—	—	0.66	0.66	20.00	20.00	1323	1840
36x6	0.74	0.36	7.00	23.50	—	—	630	—	—	0.74	0.36	8.00	23.50	685	—
36x8	0.74	0.38	9.00	23.50	—	—	739	—	—	0.74	0.38	8.50	23.50	739	—
36x10	0.74	0.47	10.00	23.50	—	—	739	—	—	0.74	0.40	10.00	23.50	830	882
36x12	0.74	0.49	10.00	23.50	—	—	959	—	—	0.74	0.42	12.50	23.50	959	—
36x14	0.74	0.56	12.50	23.50	—	—	1103	—	—	0.74	0.47	10.00	23.50	1146	—
36x16	0.74	0.57	12.50	23.50	—	—	1385	—	—	0.74	0.50	12.50	23.50	1190	—
36x18	0.74	0.59	13.00	23.50	—	—	1400	—	—	0.74	0.54	12.50	23.50	1410	—
36x20	0.74	0.60	15.00	23.50	—	—	1521	—	—	0.74	0.57	12.50	23.50	1365	—
36x24	0.74	0.61	16.00	23.50	—	—	1533	—	—	0.74	0.61	16.00	23.50	1446	1785
36x30	0.74	0.66	20.00	23.50	—	—	2270	—	—	0.74	0.66	20.00	23.50	1675	—
36	0.74	0.74	23.50	23.50	—	—	1910	—	—	0.74	0.74	23.50	23.50	2015	2655
42x12	0.82	0.62	10.00	27.50	—	—	1410	—	—	0.82	0.42	10.00	27.50	1885	—
42x24	0.82	0.62	20.00	27.50	—	—	2295	—	—	0.82	0.61	20.00	27.50	2270	2668
42x30	0.82	0.66	22.00	29.50	—	—	2337	—	—	0.82	0.66	22.00	30.00	2425	2950
42x36	0.82	0.74	30.00	30.00	—	—	3000	—	—	0.82	0.74	30.00	30.00	3000	3607
42	0.82	0.82	30.00	30.00	—	—	3169	—	—	0.82	0.82	30.00	30.00	3175	3725
48x12	0.90	0.62	9.00	32.00	—	—	2500	—	—	0.90	0.42	9.00	32.00	2535	—
48x24	0.90	0.62	23.00	32.00	—	—	2822	—	—	0.90	0.74	23.00	32.00	2870	—
48x36	0.90	0.82	33.50	33.25	—	—	3982	—	—	0.90	0.74	33.50	33.25	3900	—
48x42	0.90	0.82	33.50	33.50	—	—	4100	—	—	0.90	0.82	33.50	33.50	4100	—
48	0.90	0.82	33.50	33.50	—	—	4251	—	—	0.90	0.90	33.50	33.50	4250	4955

† Weight includes the swivel gland.

C153 DUCTILE IRON COMPACT FITTINGS

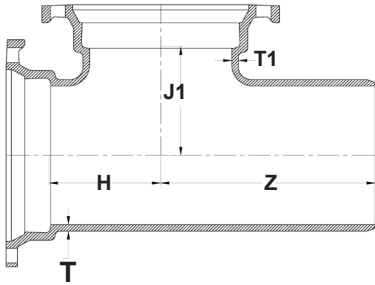

MJxPExMJ TEES												
Domestic							Import					
Size	T	T1	*H	*J1	*Z	Weight	T	T1	*H	*J1	*Z	Weight
6	0.37	0.37	5.00	5.00	11.50	57	0.37	0.37	8.00	8.00	16.00	57
8x6	0.39	0.37	5.50	6.50	11.50	79	0.39	0.37	9.00	9.00	17.00	79
8	0.39	0.39	6.50	6.50	12.50	81	0.38	0.38	9.00	9.00	17.00	77
10	0.41	0.41	7.50	7.50	13.00	133	0.40	0.40	11.00	11.00	19.00	120

Tyler Union does not recommend the use of wedge action restraints on plain end fittings.

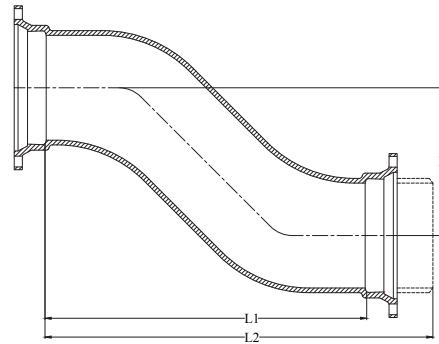
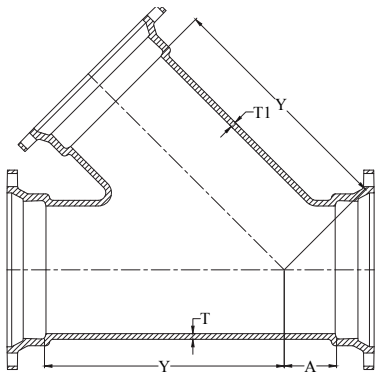

WYES/LATERAL					
Size	*A	*Y	T	T1	Weights
3	2.50	7.50	0.34	0.34	36
4x3	2.00	8.50	0.35	0.34	39
4	2.50	8.50	0.35	0.35	45
6x4	1.50	11.00	0.37	0.35	67
6	3.00	13.00	0.37	0.37	85
8x4	0.50	13.00	0.39	0.35	86
8x6	2.00	16.00	0.39	0.37	109
8	3.50	16.00	0.39	0.39	117
10x4	0.00	15.00	0.41	0.35	112
10x6	1.00	16.00	0.41	0.37	129
10x8	2.50	17.00	0.41	0.39	162
10	3.50	19.00	0.41	0.41	199
12x4	0.00	16.50	0.43	0.35	141
12x6	1.50	18.50	0.43	0.37	170
12x8	1.50	18.50	0.43	0.39	177
12x10	3.00	20.00	0.43	0.41	216
12	4.50	22.50	0.43	0.43	269
14	6.00	25.00	0.51	0.51	476
16x6	0.00	21.00	0.52	0.45	300
16x8	0.50	22.50	0.52	0.46	349
16x12	3.50	25.00	0.52	0.48	471
16	6.50	28.00	0.52	0.52	635

*Not in AWWA C153. "A" & "Y" are approximate dim.

OFFSETS (MJ x MJ) or (MJxPE)					
Import				Weights	
Size	D	L1	L2	MJ x MJ	MJ x PE
3	6.00	9.00	14.50	23	29
3	12.00	15.00	20.50	34	39
3	18.00	21.00	26.50	40	48
3	24.00	27.00	32.50	47	53
4	6.00	10.00	15.50	32	44
4	12.00	6.00	21.50	42	54
4	18.00	22.00	27.50	56	65
4	24.00	28.00	33.50	65	72
6	6.00	12.00	17.50	55	54
6	12.00	18.00	23.50	72	68
6	18.00	24.00	29.50	88	96
6	24.00	30.00	35.50	111	117
8	6.00	13.00	18.50	79	78
8	12.00	19.00	24.50	103	110
8	18.00	25.00	30.50	128	124
10	6.00	15.00	20.50	112	130
10	12.00	21.00	26.50	148	172
10	18.00	27.00	32.50	176	189
12	6.00	17.00	22.50	157	-
12	12.00	23.00	28.50	174	198
12	18.00	29.00	34.50	210	270
12	24.00	35.00	40.50	298	334
12	30.00	41.00	46.50	283	205

C153 DUCTILE IRON COMPACT FITTINGS

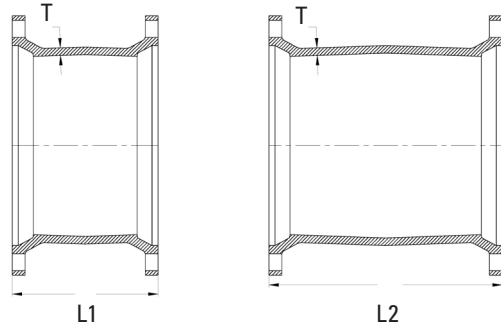
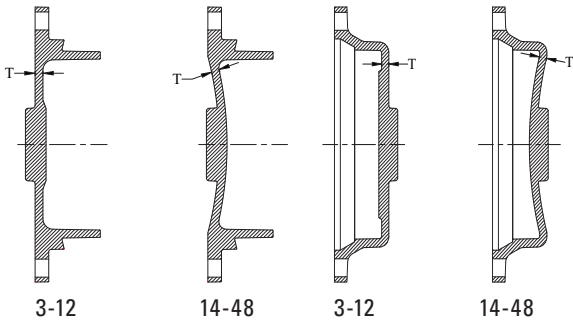

SOLID & TAPPED PLUGS & CAPS							
Domestic					Import		
Size	T	Max. Tap	Weight		T	Weight	
			Plugs	Caps		Plugs	Caps
3	0.46	2	9	8	0.33	8	8
4	0.46	2	9	10	0.34	10	9
6	0.46	2	13	18	0.36	16	15
8	0.46	2	25	26	0.38	26	22
10	0.56	2	36	32	0.40	36	32
12	0.56	2	47	46	0.42	46	42
14	0.62	2	76	85	0.47	75	66
16	0.62	2	98	94	0.50	95	92
18	0.65	2	138	121	0.54	121	114
20	0.66	2	158	149	0.57	135	125
24	0.68	2	202	232	0.61	296	198
30	0.66	2	426	345	0.66	355	345
36	0.74	2	560	626	0.74	688	628
42	0.82	2	1091	723	0.82	—	—
48	0.90	2	1455	974	0.90	—	—

SOLID SLEEVES										
Domestic						Import				
Size	T	L1	L2	Weight		T	L1	L2	Weight	
				Short	Long				Short	Long
3	0.34	7.50	12.00	13	22	0.33	7.50	12.00	12	17
4	0.35	7.50	12.00	19	25	0.34	7.50	12.00	15	20
6	0.37	7.50	12.00	28	37	0.36	7.50	12.00	23	29
8	0.39	7.50	12.00	38	49	0.38	7.50	12.00	31	45
10	0.41	7.50	12.00	48	68	0.40	7.50	12.00	45	61
12	0.43	7.50	12.00	58	81	0.42	7.50	12.00	56	76
14	0.56	9.50	15.00	107	153	0.47	9.50	15.00	94	128
16	0.57	9.50	15.00	116	174	0.50	9.50	15.00	118	159
18	0.68	9.50	15.00	154	207	0.54	9.00	15.00	145	200
20	0.69	9.50	15.00	200	249	0.57	9.00	15.00	173	236
24	0.75	9.50	15.00	232	323	0.61	9.00	15.00	226	306
30	0.74	15.00	24.00	549	640	0.66	15.00	24.00	472	634
36	0.74	15.00	24.00	725	868	0.74	15.00	24.00	673	889
42	0.82	—	24.00	—	1146	0.82	15.00	24.00	887	1150
48	0.90	—	24.00	—	1431	0.90	15.00	24.00	1136	1435

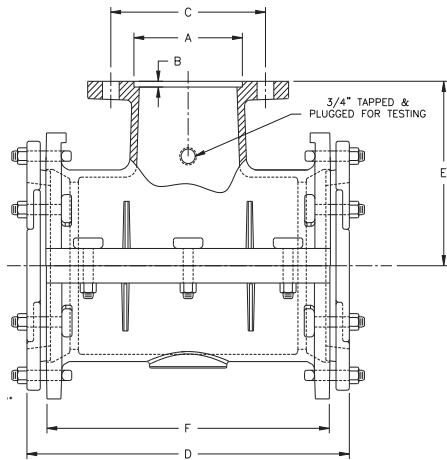

TAPPING SLEEVE FOR CAST IRON/DUCTILE IRON										
Size	A	B	C	D	E	F	Min.	Max	Weight	
6X4	5.016	0.250	7.50	15.75	8.00	12.75	6.85	7.15	104	
6	7.016	0.312	9.50	15.75	8.00	12.75	6.85	7.15	108	
8X4	5.016	0.250	7.50	16.50	9.00	13.50	9.00	9.35	134	
8X6	7.016	0.312	9.50	16.50	9.00	13.50	9.00	9.35	140	
8	9.016	0.312	11.75	16.50	9.00	13.50	9.00	9.35	148	
10X4	5.016	0.250	7.50	24.00	11.00	20.75	11.04	11.45	236	
10X6	7.016	0.312	9.50	24.00	11.00	20.75	11.04	11.45	240	
10X8	9.016	0.312	11.75	24.00	11.00	20.75	11.04	11.45	246	
10	11.016	0.312	14.25	24.00	11.00	20.75	11.04	11.45	257	
12X4	5.016	0.250	7.50	26.50	12.00	23.25	13.14	13.56	273	
12X6	7.016	0.312	9.50	26.50	12.00	23.25	13.14	13.56	286	
12X8	9.016	0.312	11.75	26.50	12.00	23.25	13.14	13.56	292	
12X10	11.016	0.312	14.25	26.50	12.00	23.25	13.14	13.56	303	
12	13.016	0.312	17.00	26.50	12.00	23.25	13.14	13.56	320	

Note: Visit www.tylerunion.com for assembly instructions.
Tapping sleeve is assembled with gland and gasket.

C153 DUCTILE IRON COMPACT FITTINGS

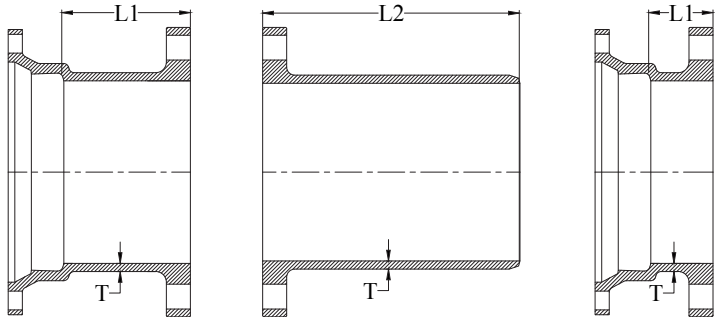
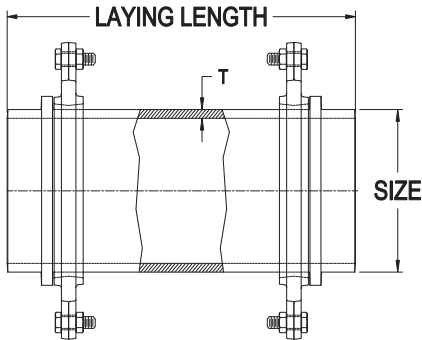

SWIVEL X SWIVEL ADAPTER		
Size by Laying Length	Wall Thickness	Weight
6x12	0.37	48
6x18	0.37	49
6x24	0.37	68

Adapter weights include swivel glands.

DOMESTIC MJxFE		FExPE		NON-DOMESTIC MJxFE			
Domestic		Weights		Import	Weight		
Size	T	L1	L2	MJxFE	FExPE	L1	MJxFE
3	0.34	6.00	12.00	18	...		
4	0.35	6.00	12.00	26	23	3.50	24
6	0.37	6.00	12.00	36	35	3.50	37
8	0.39	6.00	12.00	55	43	3.50	51
10	0.41	6.00	12.00	69	59	3.50	70
12	0.43	6.00	12.00	88	88	3.75	101
14	0.51	6.00	12.00	127	-	6.00	128
16	0.52	6.00	12.00	161	149	6.00	158
18	0.56	6.00	-	173	-	6.00	176
20	0.60	6.00	-	275	-	6.00	267
24	0.62	6.00	-	271	-	5.00	288
30	0.66	7.00	-	514	-	7.00	557
36	0.74	8.00	-	770	-	8.00	798

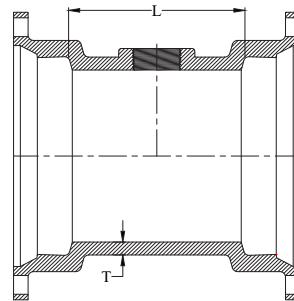
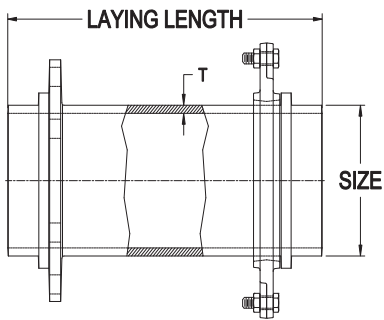

SWIVEL X SOLID ADAPTER WITH SWIVEL GLAND			
Size by Laying Length	Wall Thickness	Weight	
		Domestic	Import
6x13	0.37	46	51
6x18	0.37	64	61
6x24	0.37	75	74
8x12	0.39	63	67

Adapter weights include swivel glands.

MJ TAPPED TEE (2" TAP)					
Size	T	L	Max. Tap	Domestic	Import
3	0.34	6.00	2	22	20
4	0.35	6.00	2	30	24
6	0.37	6.00	2	44	35
8	0.39	6.00	2	50	54
10	0.41	6.00	2	92	68
12	0.43	6.00	2	165	83
16	0.52	6.00	2	177	162

C153 DUCTILE IRON COMPACT FITTINGS

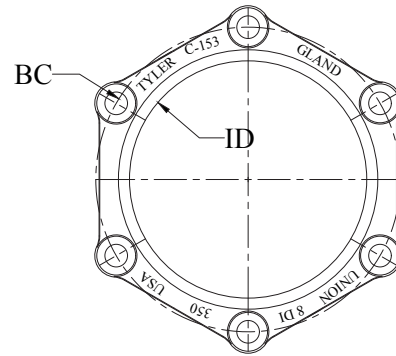
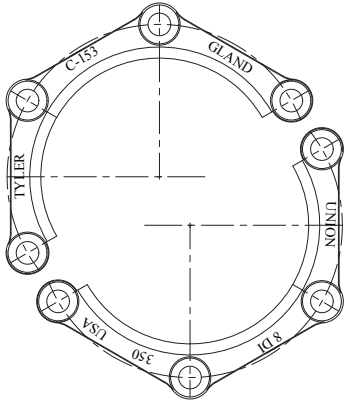

MJ COMPACT SPLIT REPAIR GLANDS			
Size	Inside Diameter (+.07-.03)	Bolt Circle (+.06)	Weight (lbs.)
4	4.90	7.50	4
6	7.00	9.50	5
8	9.15	11.75	6
10	11.20	14.00	8
12	13.30	16.25	18

Split glands work with standard MJ gaskets and standard T-head bolts. Glands are shipped in halves and do not need separate bolts. T-head bolts alone hold the halves together.

MJ GLANDS			
Size	Weight	Size	Weight
3	3	18	22
4	4	20	32
6	5	24	37
8	6	30	85
10	9	36	115
12	10	42	180
14	17	48	275
16	21	—	—

MJ ACCESSORY KITS AND WEIGHTS						
Size	No.	Bolt Size	Bolt Length	Bolt Torque ft-lbs	Wt. of Gland, Bolt and Gasket	Pipe Barrel O.D.
3	4	5/8	3	45-60	4.4	3.96
4	4	3/4	3 1/2	75-90	6.9	4.8
6	6	3/4	3 1/2	75-90	9.8	6.9
8	6	3/4	4	75-90	11.3	9.05
10	8	3/4	4	75-90	15.6	11.1
12	8	3/4	4	75-90	17.3	13.2
14	10	3/4	4 1/2	75-90	26.5	15.3
16	12	3/4	4 1/2	75-90	31.9	17.4
18	12	3/4	4 1/2	75-90	36.2	19.5
20	14	3/4	4 1/2	75-90	42.2	21.6
24	16	3/4	5	75-90	54.2	25.8
30	20	1	6	100-120	224	32
36	24	1	6	100-120	179.7	38.3
42	28	1 1/4	6 1/2	120-150	382	44.5
48	32	1 1/4	6 1/2	120-150	463	50.8
54	36	1 1/4	6 1/2	120-150	—	57.56
60	36	1 1/4	6 1/2	120-150	—	61.61
64	38	1 1/4	6 1/2	120-150	—	65.67

C153 DUCTILE IRON COMPACT FITTINGS

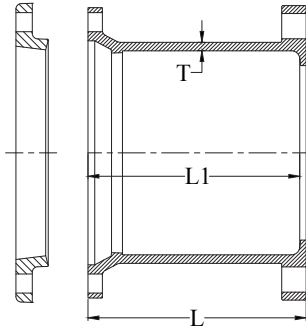

MJxFE Cutting-In Sleeve with Dual Purpose Accessories					
Size	For Pipe Size	L	L1	T	Shipping Wt. Assembled
4	4.80–5.00 O.D.	10.00	9.50	0.35	33
6	6.90–7.10 O.D.	10.00	9.50	0.37	50
8	9.05–9.30 O.D.	10.00	9.50	0.39	67
10	11.10–11.40 O.D.	10.00	9.50	0.41	122
12	13.20–13.50 O.D.	10.00	9.50	0.43	157

Flanged ends are faced and drilled per ANSI/AWWA C110/A21.10. Mechanical joint ends are designed to receive both standard and oversize gray or ductile iron pipe as shown above.

Typical Cutting-in Sleeve Installations

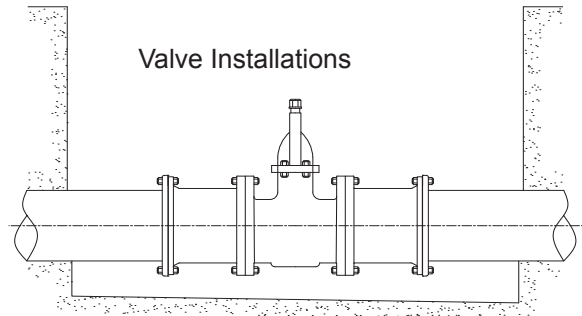
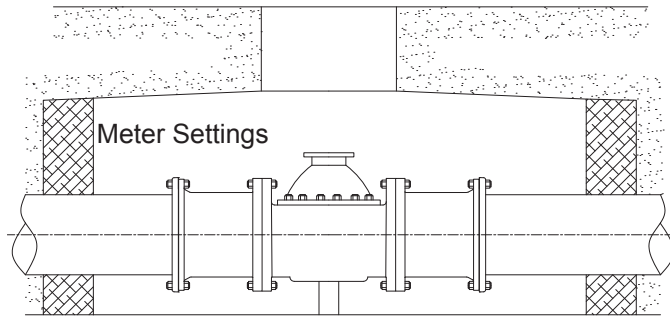

MJ Hydrant Bury

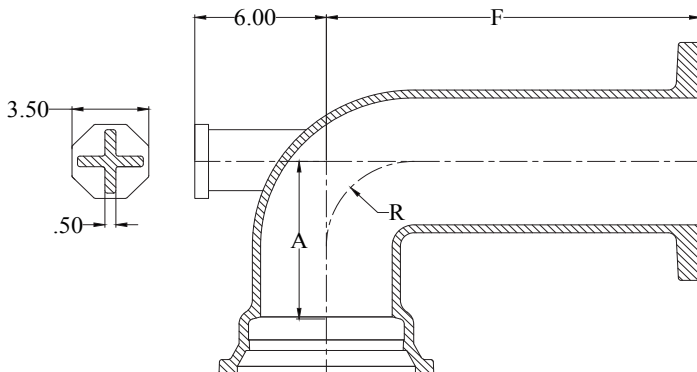

MJ HYDRANT BURY			
Size	A	F	R
6x30	7.50	30.00	4.00
6x36	7.50	36.00	4.00
6x42	7.50	42.00	4.00
6x48	7.50	48.00	4.00

Note: Please specify 8-bolt-hole flange or 6-bolt-hole flange upon order placement.

C110 DUCTILE IRON FULL BODY FITTINGS

SAMPLE SPECIFICATIONS

(Current ANSI/AWWA revisions apply)

Mechanical joint water main fittings with accessories 2" through 48" shall be manufactured from ductile iron in accordance with and meet all applicable terms and provisions of standards ANSI/AWWA C110/A21.10 and ANSI/AWWA C111/A21.11. Ductile iron mechanical joint fittings 2" through 24" shall be rated for 350 psi working pressure. All ductile iron mechanical joint fittings 30" through 48" shall be rated for 250 psi working pressure. Flanged ductile iron fittings in 4" through 24" may be rated for 350 psi (2,413 kPa) with the use of special (annular ring or comparable) gaskets.

NOTE: EXCEPTIONS: Mechanical joint fittings with flanged branches and 14" and larger caps and plugs are rated for water pressure of 250 psi.

NOTE: Installation per AWWA C600 and AWWA C651, current revision.

NOTE: Fittings are cement lined and seal coated in accordance with ANSI/AWWA C104/A21.4. Fittings are also available double cement lined, bare or epoxy coated. Coated and lined fittings meet requirements of NSF-61, NSF-372 & Annex G.

Nominal Joint Dimensions in Inches																
Size	A	B	C	D	F	θ	X	J	K1	K2	L	M	N	O	S	
*2	2.50	2.50	3.39	3.50	2.61	28°	3/4	4.75	6.25	6.25	0.75	0.62	1.12	0.31	0.44	
3	3.96	2.50	4.84	4.94	4.06	28°	3/4	6.19	7.69	7.69	0.94	0.62	1.37	0.31	0.52	
4	4.80	2.50	5.92	6.02	4.90	28°	7/8	7.50	9.12	9.12	1.00	0.75	1.50	0.31	0.65	
6	6.90	2.50	8.02	8.12	7.00	28°	7/8	9.50	11.12	11.12	1.06	0.88	1.63	0.31	0.70	
8	9.05	2.50	10.17	10.27	9.15	28°	7/8	11.75	13.37	13.37	1.12	1.00	1.75	0.31	0.75	
10	11.10	2.50	12.22	12.34	11.20	28°	7/8	14.00	15.69	15.62	1.19	1.00	1.75	0.31	0.80	
12	13.20	2.50	14.32	14.44	13.30	28°	7/8	16.25	17.94	17.88	1.25	1.00	1.75	0.31	0.85	
14	15.30	3.50	16.40	16.54	15.44	28°	7/8	18.75	20.31	20.25	1.31	1.25	2.00	0.31	0.89	
16	17.40	3.50	18.50	18.64	17.54	28°	7/8	21.00	22.56	22.50	1.38	1.31	2.06	0.31	0.97	
18	19.50	3.50	20.60	20.74	19.64	28°	7/8	23.25	24.83	24.75	1.44	1.38	2.13	0.31	1.05	
20	21.60	3.50	22.70	22.84	21.74	28°	7/8	25.50	27.08	27.00	1.50	1.44	2.19	0.31	1.12	
24	25.80	3.50	26.90	27.04	25.94	28°	7/8	30.00	31.58	31.50	1.62	1.56	2.31	0.31	1.22	
30	32.00	4.00	33.29	33.46	32.17	20°	1 1/8	36.88	39.12	39.12	1.81	2.00	2.75	0.38	1.50	
36	38.30	4.00	39.59	39.76	38.47	20°	1 1/8	43.75	46.00	46.00	2.00	2.00	2.75	0.38	1.80	
42	44.50	4.00	45.79	45.96	44.67	20°	1 3/8	50.62	53.12	53.12	2.00	2.00	2.75	0.38	1.95	
48	50.80	4.00	52.09	52.26	50.97	20°	1 3/8	57.50	60.00	60.00	2.00	2.00	2.75	0.38	2.20	

*Not included in AWWA C110.

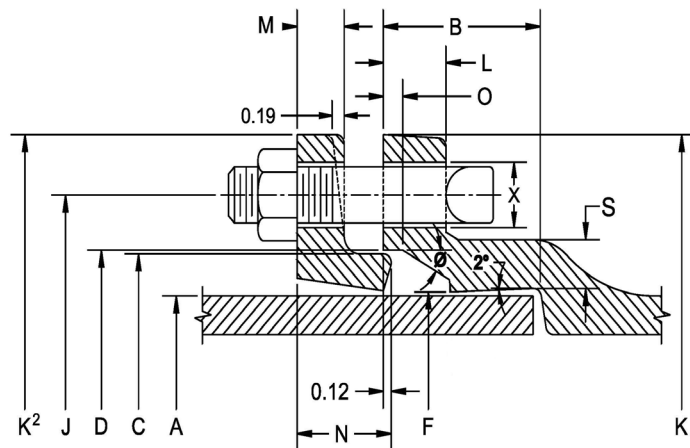

ANSI/AWWA C110 Mechanical Joint Fittings

C110 DUCTILE IRON FULL BODY FITTINGS

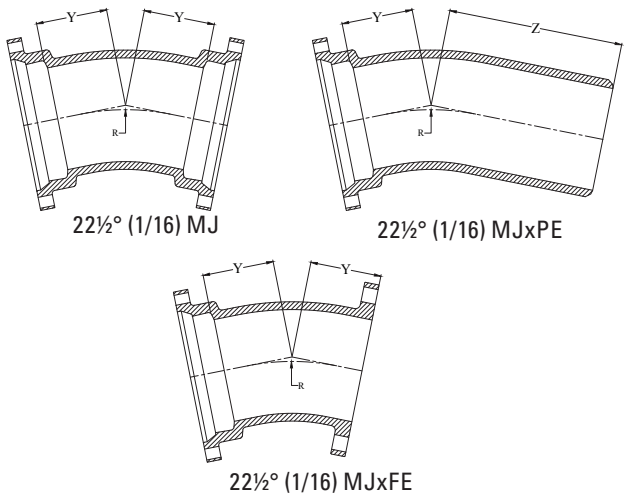
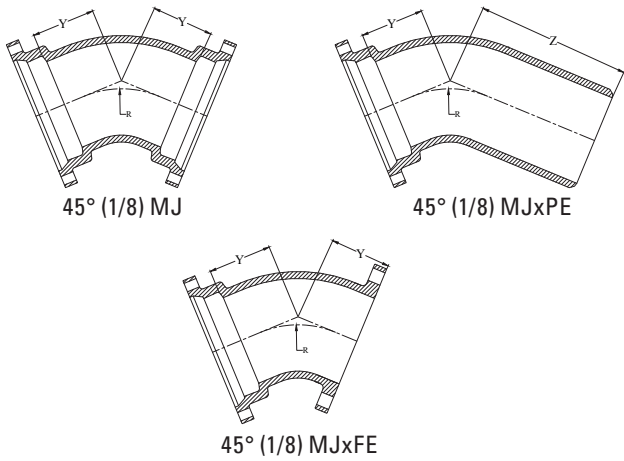
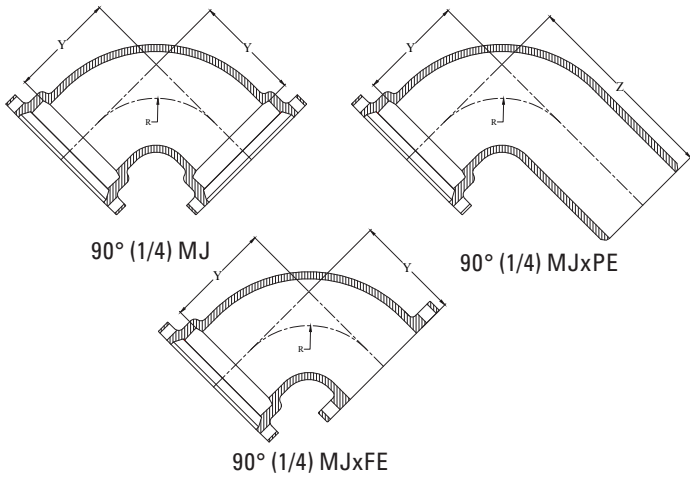

*Not included in ASSA C110.

90° (1/4) BENDS								
Size	Domestic			Weight			Import	
	R	Y	Z	MJxMJ	MJxPE	MJxFE	MJ	MJxPE
	*2	2.30	3.30	—	16	—	—	—
3	4.00	5.50	13.50	26	36	—	35	35
4	4.50	6.50	14.50	56	53	47	55	50
6	6.00	8.00	16.00	88	80	75	88	97
8	7.00	9.00	17.00	123	119	118	136	153
10	9.00	11.00	19.00	182	181	170	190	190
12	10.00	12.00	20.00	280	252	246	255	255
14	11.50	14.00	22.00	380	—	—	400	—
16	12.50	15.00	23.00	552	—	465	480	410
18	14.00	16.50	24.50	625	600	591	641	577
20	15.50	18.00	26.00	862	775	—	725	650
24	18.50	22.00	30.00	1423	1301	1150	1020	985
30	21.50	25.00	33.00	1942	1920	—	1843	1585
36	24.50	28.00	36.00	2629	2310	—	2513	2310
42	27.50	31.00	—	3410	—	—	3410	—
48	30.50	34.00	—	4595	—	—	4595	—

45° (1/8) BENDS								
Size	Domestic			Weight			Import	
	R	Y	Z	MJ	MJxFE	MJxPE	MJ	MJxPE
	*2	1.96	1.80	—	12	—	—	—
3	3.62	3.00	11.00	30	—	—	30	30
4	4.81	4.00	12.00	53	48	45	49	48
6	7.25	5.00	13.00	77	60	69	77	81
8	8.44	5.50	13.50	110	107	111	117	123
10	10.88	6.50	14.50	156	148	167	155	168
12	13.25	7.50	15.50	214	215	196	223	215
14	12.06	7.50	15.50	300	—	—	270	—
16	13.25	8.00	16.00	391	—	349	335	320
18	14.50	8.50	16.50	527	416	455	467	395
20	16.88	9.50	17.50	631	543	537	527	500
24	18.12	11.00	19.00	880	1099	825	754	715
30	27.75	15.00	23.00	1898	—	1510	1451	1275
36	35.00	18.00	26.00	2372	—	1930	2176	1930
42	42.25	21.00	—	3020	—	—	2955	—
48	49.50	24.00	—	4170	—	—	4080	—

22 1/2° (1/16) BENDS								
Size	Domestic			Weight			Import	
	R	Y	Z	MJ	MJxFE*	MJxPE	MJ	MJxPE
	3	7.56	3.00	11.00	30	—	—	30
4	10.06	4.00	12.00	52	—	—	51	45
6	15.06	5.00	13.00	77	71	70	75	70
8	17.62	5.50	13.50	110	107	163	108	108
10	22.62	6.50	14.50	156	155	163	159	160
12	27.62	7.50	15.50	214	215	212	199	220
14	25.12	7.50	15.50	300	—	—	275	—
16	27.62	8.00	16.00	391	344	334	318	325
18	30.19	8.50	16.50	527	422	423	430	405
20	35.19	9.50	17.50	631	—	575	545	505
24	37.69	11.00	19.00	880	800	930	758	725
30	57.81	15.00	23.00	1898	—	1540	1400	1400
36	72.88	18.00	26.00	2372	—	1970	2121	1970
42	88.00	21.00	—	3020	—	—	3020	—
48	103.06	24.00	—	4170	—	—	4170	—

Tyler Union does not recommend the use of wedge action restraints on plain end fittings



C110 DUCTILE IRON FULL BODY FITTINGS

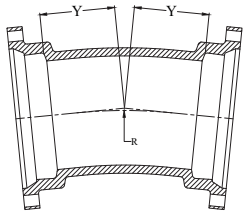

11¼° (1/32) MJ

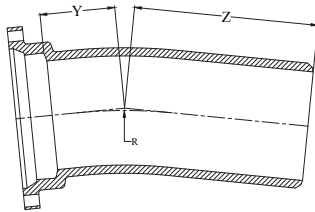

11¼° (1/32) MJxPE

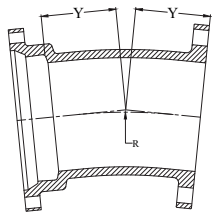

11¼° (1/32) MJxFE

11 1/4° (1/32) BENDS								
Size	R	Y	Z	Domestic			Import	
				Weight			Weight	
				MJ	MJxFE	MJxPE	MJ	MJxPE
3	15.25	3.00	11.00	30	—	—	29	—
4	20.31	4.00	12.00	52	—	45	51	—
6	30.50	5.00	13.00	65	71	70	75	—
8	35.50	5.50	13.50	104	105	105	108	105
10	45.69	6.50	14.50	171	—	—	160	—
12	55.81	7.50	15.50	221	215	—	220	—
14	50.75	7.50	15.50	305	—	—	275	—
16	55.81	8.00	16.00	405	345	—	345	—
18	60.94	8.50	16.50	525	422	—	450	—
20	71.06	9.50	17.50	644	—	—	540	—
24	76.12	11.00	19.00	996	800	972	762	730
30	116.75	15.00	23.00	1410	—	1305	1407	1305
36	147.25	18.00	26.00	2397	—	2185	2161	1980
42	177.69	21.00	—	3035	—	—	3740	—
48	208.12	24.00	—	4190	—	—	4190	—

90° (1/4) SWIVEL X SWIVEL BENDS									
Size	Wall Thickness	A	B	C	D	E	F	R	*Weight
6	0.55	10.50	15.50	7.10	11.12	6.90	8.02	6.00	106
8	0.60	11.50	16.50	9.20	13.37	9.05	10.17	7.00	156

NOTE: Includes 2 swivel glands.
*Not included in AWWA C110.

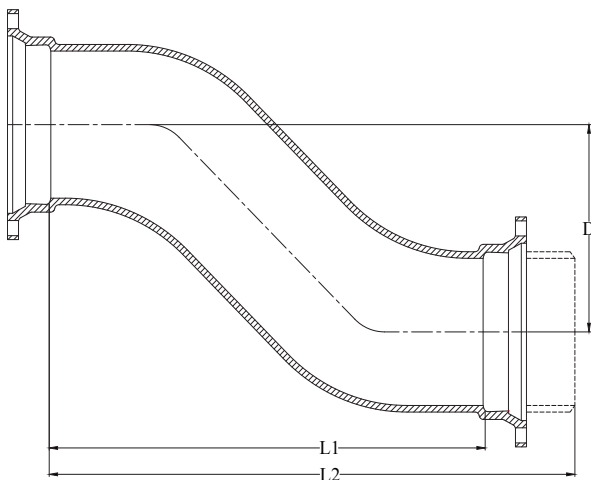
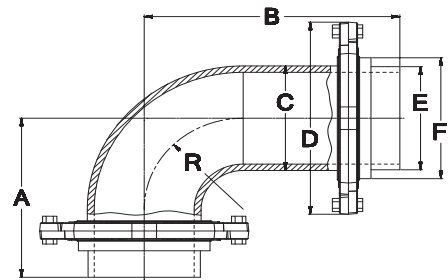

OFFSETS					
Size	D	L	L2	Weight	
				MJ X MJ	MJ X PE
4	6.00	19.00	27.00	—	82
4	12.00	22.00	30.00	85	80
4	18.00	30.00	38.00	105	—
4	24.00	26.00	34.00	126	125
6	6.00	20.00	28.00	114	105
6	12.00	26.00	34.00	148	143
6	18.00	33.00	41.00	188	176
6	24.00	24.00	32.00	182	160
8	6.00	21.00	29.00	177	155
8	12.00	28.00	36.00	231	195
8	18.00	35.00	43.00	287	282
8	24.00	36.00	44.00	280	285
10	12.00	30.00	38.00	347	280
10	18.00	38.00	46.00	340	340
10	24.00	38.00	46.00	420	—
12	12.00	37.00	45.00	420	420
12	18.00	48.00	56.00	520	520
12	24.00	48.00	56.00	649	630
16	12.00	40.00	48.00	715	—
16	18.00	50.00	58.00	850	830
20	12.00	40.00	48.00	1025	—
20	18.00	48.00	60.00	1362	—

Tyler Union does not recommend the use of wedge action restraints on plain end fittings.

C110 DUCTILE IRON FULL BODY FITTINGS

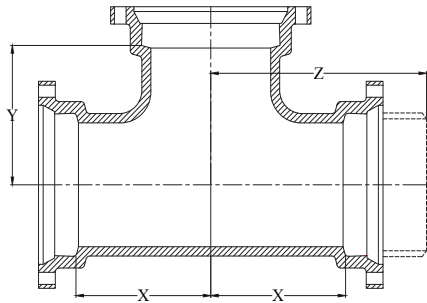

MJ Tees and MJxPExMJ Tees

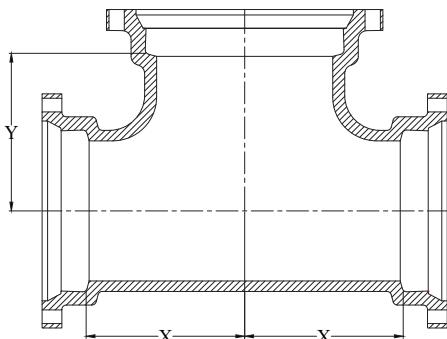

MJ Bullhead Tees

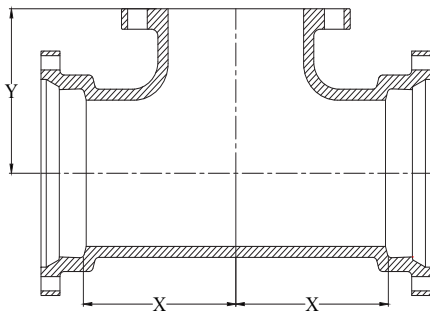

MJxFE Tees

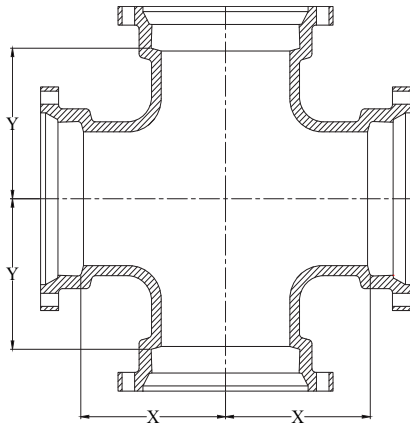

Cross

TEES AND CROSSES								
Size Run	Branch	X	Y	Z	MJ	Weight		
						MJXPEXMJ	MJXMJXFE	Cross
2	2	3.25	3.25	-	21	-	-	-
3	2	3.25	3.25	-	45	-	-	-
3	3	5.50	5.50	13.50	58	-	-	-
4	2	4.80	4.80	14.50	68	-	49	-
4	3	6.50	6.50	14.50	77	-	-	-
4	4	6.50	6.50	14.50	78	75	76	-
4	6	8.00	8.00	-	112	-	-	-
6	2	8.00	8.00	-	78	-	-	-
6	3	8.00	8.00	16.00	98	-	-	-
6	4	8.00	8.00	16.00	110	-	109	-
6	6	8.00	8.00	16.00	119	120	141	160
6	8	9.00	9.00	-	158	-	-	-
8	3	9.00	9.00	17.00	155	-	-	-
8	4	9.00	9.00	17.00	157	-	150	185
8	6	9.00	9.00	17.00	175	170	182	205
8	8	9.00	9.00	17.00	199	180	194	255
10	4	11.00	11.00	19.00	-	-	229	-
10	6	11.00	11.00	19.00	258	-	264	285
10	8	11.00	11.00	19.00	268	-	245	310
10	10	11.00	11.00	19.00	300	250	-	380
12	4	12.00	12.00	20.00	318	315	323	-
12	6	12.00	12.00	20.00	325	325	335	360
12	8	12.00	12.00	20.00	335	335	372	371
12	10	12.00	12.00	20.00	392	390	-	486
12	12	12.00	12.00	20.00	396	396	476	-
14	12	14.00	14.00	22.00	540	560	-	-
14	14	14.00	14.00	22.00	585	570	-	779
16	4	15.00	15.00	23.00	580	580	575	-
16	6	15.00	15.00	23.00	615	590	605	650
16	8	15.00	15.00	23.00	625	605	615	675
16	10	15.00	15.00	23.00	645	620	-	-
16	12	15.00	15.00	23.00	627	640	651	-
16	16	15.00	15.00	23.00	740	720	730	895
18	6	13.00	15.50	-	710	-	707	-
18	8	13.00	15.50	-	659	-	675	775
18	12	13.00	15.50	-	749	-	733	860
18	18	16.50	16.50	-	945	-	953	1140
20	6	14.00	17.00	-	849	-	-	-
20	8	14.00	17.00	-	892	-	859	951
20	12	14.00	17.00	-	896	-	-	977
20	16	18.00	18.00	-	1095	-	-	1245
20	20	18.00	18.00	-	1258	-	1168	1440
24	6	15.00	19.00	-	1233	-	1228	-
24	8	15.00	19.00	-	1234	-	1242	1244
24	12	15.00	19.00	-	1256	-	1165	1326
24	14	15.00	19.00	-	1220	-	-	-
24	16	15.00	19.00	-	1245	-	-	1479
24	18	22.00	22.00	-	1735	-	-	-
24	20	22.00	22.00	-	1720	-	1795	1965
24	24	22.00	22.00	-	1947	-	-	2192
30	6	18.00	23.00	-	2050	-	-	2085
30	8	18.00	23.00	-	2060	-	-	-
30	10	18.00	23.00	-	2075	-	-	-
30	12	18.00	23.00	-	2090	-	-	2165
30	16	18.00	23.00	-	2145	-	-	-
30	18	18.00	23.00	-	2170	-	-	-
30	20	18.00	23.00	-	2205	-	-	-
30	24	25.00	25.00	-	2880	-	3080	3180
30	30	25.00	25.00	-	2275	-	2430	3640

Tyler Union does not recommend the use of wedge action restraints on plain end fittings.

C110 DUCTILE IRON FULL BODY FITTINGS

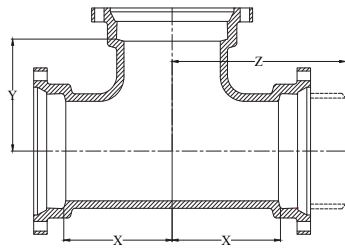

MJ Tees AND MJxPExMJ Tees

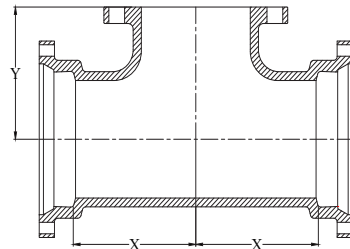

MJxFE Tees

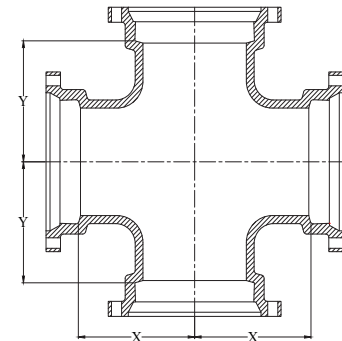

Cross

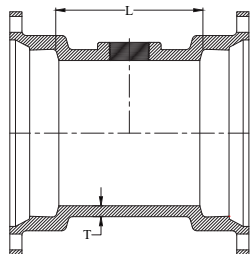

MJ Tapped Tees (2" TAP)

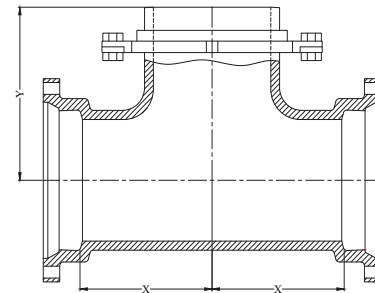

MJxMJxSwivel Tees

TEES AND CROSSES (Continued)								
Size Run	Branch	X	Y	Z	MJ	Weight		
						MJXPEXMJ	MJxMJxFE	Cross
36	6	20.00	26.00	—	2439	—	—	—
36	8	20.00	26.00	—	2444	—	—	—
36	10	20.00	26.00	—	2535	—	2550	—
36	12	20.00	26.00	—	2541	—	—	—
36	14	20.00	26.00	—	2570	—	2450	—
36	16	20.00	26.00	—	2585	—	—	4370
36	18	20.00	26.00	—	2610	—	—	3420
36	20	20.00	26.00	—	2635	—	2660	3455
36	24	20.00	26.00	—	2792	—	—	3495
36	30	28.00	28.00	—	3545	—	—	3535
36	36	28.00	28.00	—	3450	—	—	3590
42	12	23.00	30.00	—	3555	—	—	3690
42	14	23.00	30.00	—	3575	—	—	4815
42	16	23.00	30.00	—	3595	—	—	6430
42	18	23.00	30.00	—	3615	—	—	6920
42	20	23.00	30.00	—	3640	—	—	4665
42	24	23.00	30.00	—	3690	—	—	4695
42	30	31.00	31.00	—	4650	—	—	4735
42	36	31.00	31.00	—	4880	—	—	4775
42	42	31.00	31.00	—	6320	—	—	4825
48	12	26.00	34.00	—	4870	—	—	—
48	14	26.00	34.00	—	4885	—	—	—
48	16	26.00	34.00	—	4905	—	—	—
48	18	26.00	34.00	—	4925	—	—	—
48	20	26.00	34.00	—	4950	—	—	—
48	24	26.00	34.00	—	4995	—	—	4920
48	30	26.00	34.00	—	5140	—	—	5210
48	36	34.00	34.00	—	6280	—	—	6500
48	42	34.00	34.00	—	8130	—	—	8530
48	48	34.00	34.00	—	8420	—	—	9095

MJ TAPPED TEE (2" TAP)							
Domestic				Import			
size	L	Max. Tap	Weight	T	L	Max. Tap	Weight
3	8.00	2	40	0.33	6.00	2	18
4	8.00	2	51	0.34	6.00	2	24
6	8.00	2	73	0.36	6.00	2	42
8	8.00	2	104	0.38	6.00	2	52
10	8.00	2	130	0.40	6.00	2	64
12	8.00	2	180	0.42	6.00	2	81

Tyler Union does not recommend the use of wedge action restraints on plain end fittings

MJ X MJ X SWIVEL TEE			
Size	X	Y	Weight
6	8.00	10.50	150
8x6	9.00	11.50	199
8	9.00	11.50	210
10x6	11.00	13.50	267
12x6	12.00	14.50	346
16x6	15.00	17.50	619
16x8	15.00	17.50	649
30x6	18.00	24.50	2070

All weights shown include the swivel gland.

C110 DUCTILE IRON FULL BODY FITTINGS

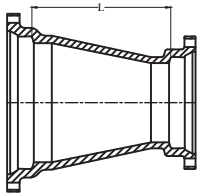

MJ x MJ

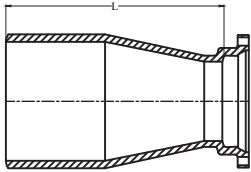

PE x MJ-SEB

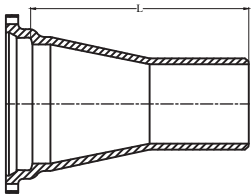

MJ-LEB x PE

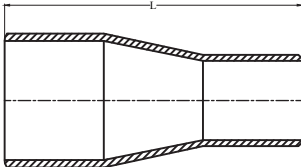

PE x PE

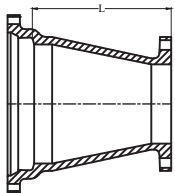

MJ x FE

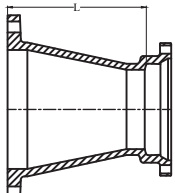

FE x MJ

REDUCERS												
Size	Laying Length (L)						Weight					
	MJ	SEB	MJ-LEB	PE x PE	FE x MJ	MJ x FE	MJ	MJ-SEB	MJ-LEB	PE x PE	FE x MJ	MJ x FE
* 3x2	6	14	14	—	—	—	24	24	24	—	—	—
* 4x2	7	15	15	—	—	—	31	30	31	—	—	—
4x3	7	15	15	23	7	7	37	38	37	34	34	35
* 6x2	9	17	17	—	—	—	46	43	47	—	—	—
6x3	9	17	17	25	—	9	55	50	55	—	—	50
6x4	9	17	17	25	9	9	56	60	59	57	53	62
8x3	11	19	19	27	—	—	84	77	70	—	—	—
8x4	11	19	19	27	11	11	84	82	84	—	73	75
8x6	11	19	19	27	11	11	94	90	93	96	84	80
10x6	12	20	20	28	12	12	115	116	117	—	100	105
10x8	12	20	20	28	12	12	142	135	130	135	130	130
12x4	14	22	22	30	—	—	139	131	—	—	—	—
12x6	14	22	22	30	14	12	148	150	153	...	145	130
12x8	14	22	22	30	14	12	173	168	165	168	170	175
12x10	14	22	22	30	14	12	194	190	178	185	188	190
14x6	16	24	24	32	—	16	—	—	—	—	—	195
14x8	16	24	24	32	—	16	—	—	—	—	—	215
14x12	16	24	24	32	—	16	—	—	—	—	—	270
16x6	18	26	26	34	—	—	250	...	—	—	—	—
16x8	18	26	26	34	—	—	288	248	—	—	—	—
16x10	18	26	26	34	—	—	300	...	—	—	—	—
16x12	18	26	26	34	18	18	330	304	325	—	305	325
16x14	18	26	26	34	—	—	370	—	—	—	—	—
18x8	19	27	27	35	—	19	320	—	—	—	—	300
18x10	19	27	27	35	—	—	388	—	—	—	—	—
18x12	19	27	27	35	—	19	380	355	—	—	—	405
18x14	19	27	27	35	—	—	450	...	—	—	—	—
18x16	19	27	27	35	—	19	476	...	—	—	—	445
20x10	20	28	28	36	—	—	410	...	—	—	—	—
20x12	20	28	28	36	—	—	515	420	—	—	—	—
20x16	20	28	28	36	—	20	578	525	510	—	—	510
20x18	20	28	28	36	—	...	575	...	—	—	—	—
24x12	24	32	32	40	—	24	610	570	—	—	—	455
24x16	24	32	32	40	—	—	705	665	753	—	—	—
24x18	24	32	32	40	—	—	789	720	—	—	—	—
24x20	24	32	32	40	—	—	815	775	804	—	—	—
*30x16	30	38	38	46	—	—	1150	1040	—	1015	—	—
30x18	30	38	38	46	—	—	1160	1050	—	1025	—	—
30x20	30	38	38	46	—	—	1225	1120	—	1090	—	—
30x24	30	38	38	46	—	—	1360	1255	1320	1215	—	—
36x20	36	44	44	52	—	—	1495	—	1466	—	—	—
36x24	36	44	44	52	—	—	1580	—	1535	1389	—	—
36x30	36	44	44	52	—	—	1919	1721	...	1585	—	—
42x24	42	50	50	58	—	—	2060	—	—	—	—	—
42x30	42	50	50	58	—	—	2370	—	—	—	—	—
42x36	42	50	50	58	—	—	2695	—	—	—	—	—
48x30	48	56	56	64	—	—	3005	—	—	—	—	—
48x36	48	56	56	64	—	—	3370	—	—	—	—	—
48x42	48	56	56	64	—	—	3750	—	—	—	—	—

Tyler Union does not recommend the use of wedge action restraints on plain end fittings.

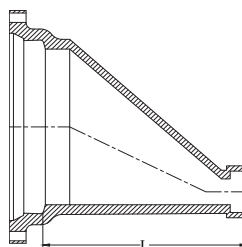

MJxFIPT Eccentric Reducer		
Size	L	Weight
6x2	13	51
8x2	15	71

C110 DUCTILE IRON FULL BODY FITTINGS

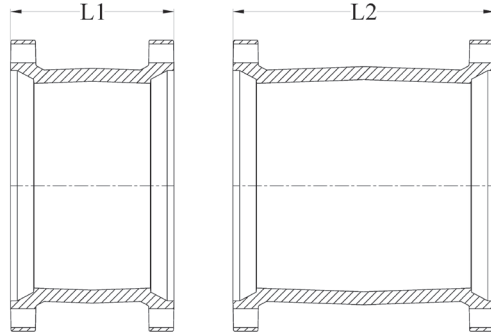
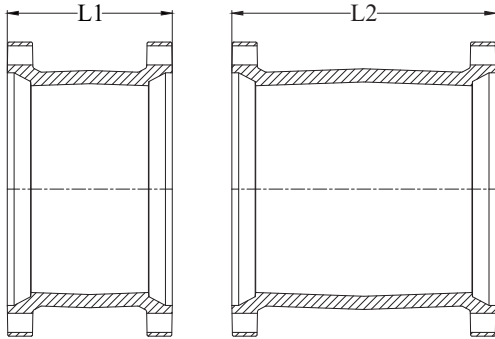

SOLID SLEEVES					
Size	Pipe O.D.	L1	Weight	L2	Weight
*2	2.50	8.00	13	12.00	18
3	4.00	7.50	25	12.00	36
4	4.80	7.50	35	12.00	47
6	6.90	7.50	45	12.00	65
8	9.10	7.50	65	12.00	90
10	11.10	7.50	85	12.00	108
12	13.20	7.50	120	12.00	136
16	17.40	9.50	206	15.00	289
18	19.50	9.50	246	15.00	282
20	21.60	9.50	275	15.00	336
24	25.80	9.50	360	15.00	459
30	32.00	15.00	745	24.00	1220
36	38.30	15.00	1047	24.00	1502
42	44.50	15.00	1312	24.00	1550
48	50.80	15.00	1585	24.00	1940

*DUO PURPOSE SLEEVE					
Size	Pipe O.D.	L1	Weight	L2	Weight
4	4.80/5.00	7.50	33	12.00	44
6	6.90/7.10	7.50	46	12.00	67
8	9.05/9.30	7.50	65	12.00	88
10	11.10/11.40	-	-	12.00	111
†12	13.20/13.50	-	-	12.00	221
†16	17.40/17.80	-	-	15.00	385

All sizes use MJ Duo purpose Gland.

* Not included in AWWA C110.

† 12" and 16" are sold assembled.

NOTE: Sizes 4"-10" Use standard MJ Gasket;

12" and 16" require special gaskets.

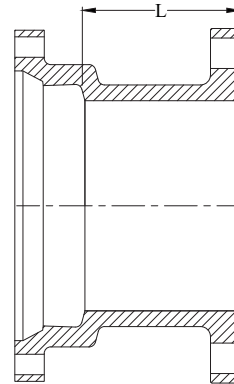
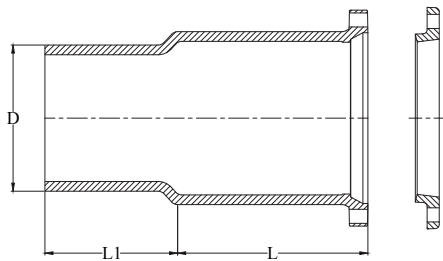

* MJ x PE DUAL-PURPOSE CUTTING-IN SLEEVE						
Size	For use on pipe OD	L	L1	D	Gland only	Gland and sleeve
4	4.80-5.00	12.00	8.00	4.80	6.0	72
6	6.90-7.10	12.00	8.00	6.90	10.0	94
8	9.05-9.30	12.00	8.00	9.05	16.0	122
10	11.10-11.40	12.00	8.00	11.10	25.0	175
12	13.20-13.50	12.00	8.00	13.20	30.0	235

Tyler Union does not recommend the use of wedge action restraints on plain end fittings.

ADAPTERS MJ x FE		
Size	L	Weight
3	8.00	30
4	8.00	42
6	8.00	57
8	8.00	88
10	8.00	120
12	8.00	150
16	8.00	257
18	8.00	304
20	8.00	372
24	8.00	488
30	10.00	682
36	10.00	1070

C110 DUCTILE IRON FULL BODY FITTINGS

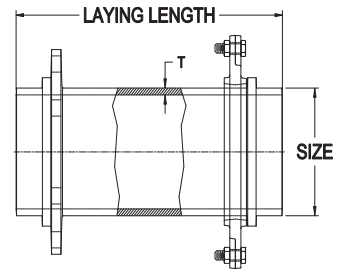
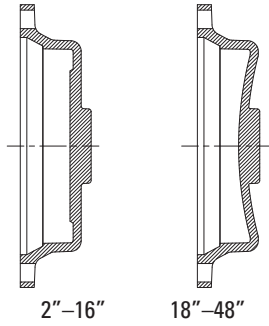
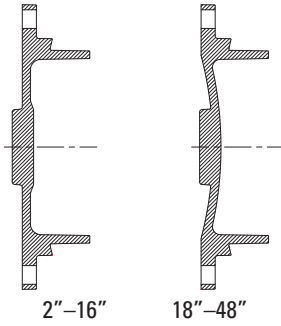

PLUGS	
Size	Weight
*2	5
3	9
4	13
6	15
8	45
10	66
12	79
14	120
16	147
†18	192
†20	220
†24	338
†30	660
†36	838
†42	1180
†48	1455

† Dished
* Not included in AWWA C110.
Note: Optional 2" tap in the center.

CAPS	
Size	Weight
*2	6
3	10
4	18
6	34
8	46
10	58
12	86
16	178
†18	215
†20	250
†24	370
†30	680
†36	850
†42	1180
†48	1595

† Dished
* Not included in AWWA C110.
Note: Optional 2" tap in the center.

SWIVEL x SOLID ADAPTER		
Size X Laying Length	Pipe O.D.	L
4 X 13	0.52	42
6 X 12	0.55	61
6 X 18	0.55	89
6 X 24	0.55	108
6 X 36	0.55	156
8 X 13	0.60	97
12 X 13	0.75	164

Weights with Gland.

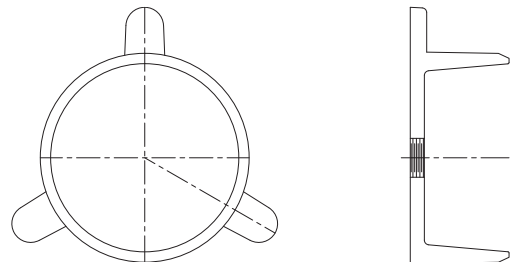
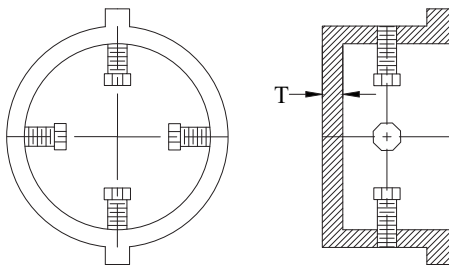

TYTON® PLUG** SOLID OR TAPPED			
Size	Tap	T	Weight**
4	2	0.60	18
6	2	0.65	25
8	2	0.70	46
10	2	0.75	70
12	2	0.75	95

Weights do not include accessories.
** Not included in AWWA C110.
TYTON is a registered trademark of U.S. Pipe and Foundry company.

PUSH-IN PLUG WITH EARS		
Size	Tap	Weight
14	2	101
16	2	137
18	2	177
†20	2	239
†24	2	311

† Dished — Not flat as shown.
NOTE: To be used with all push in pipe and fittings.
NOTE: Blocking still required ears for assembly only.



C110 DUCTILE IRON FULL BODY FITTINGS

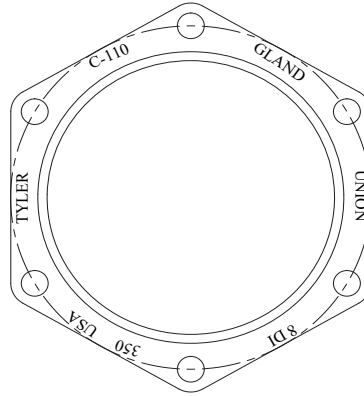
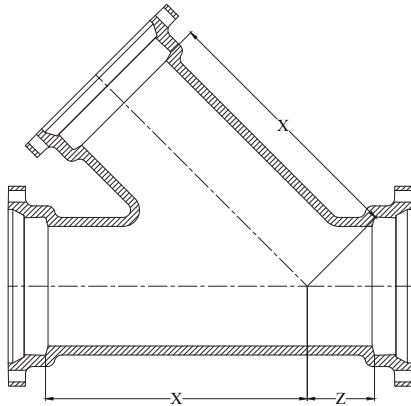

WYES / LATERALS				
Size		Dimensions		Weight
Run	Branch	X	Z	
3	3	10.00	3.00	60
4	4	12.00	3.00	90
6	4	14.50	3.50	130
6	6	14.50	3.50	145
8	4	17.50	4.50	190
8	6	17.50	4.50	205
8	8	17.50	4.50	230
10	6	20.50	5.00	330
10	8	20.50	5.00	310
10	10	20.50	5.50	435
12	8	24.50	5.50	505
12	12	24.50	5.50	490
14	6	27.00	6.00	626
16	16	30.00	6.50	1079
18	8	32.00	7.00	1073
18	10	32.00	7.00	975
18	12	32.00	7.00	1015
18	16	32.00	7.00	1135
18	18	32.00	7.00	1130
20	10	35.00	8.00	1220
20	12	35.00	8.00	1260
20	16	35.00	8.00	1375
20	20	35.00	8.00	1525
24	24	40.50	9.00	2372
30	30	49.00	10.00	3670
36	24	54.00	15.00	5390
36	36	60.00	19.50	6335
42	24	60.00	12.00	6810
42	30	63.00	12.00	7210
42	36	66.00	12.00	8355
42	42	71.00	15.00	9900
48	48	77.00	16.00	13150

* Not included in AWWA C-110.

MJ GLANDS	
Size	Weight
2	3
3	4
4	6
6	10
8	16
10	19
12	26
14	34
16	54
18	52
20	73
24	91
30	90
36	127
42	279
48	341

MJ ACCESSORY KITS AND WEIGHTS						
size	No.	Bolt Size	Bolt Length	Bolt Torque ft/lbs	Wt. of Gland, Bolts and Gasket	Pipe Barrel O.D.
*2	2	5/8	3	45-60	5	2.50
3	4	5/8	3	45-60	7	3.96
4	4	3/4	3 1/2	75-90	10	4.80
6	6	3/4	3 1/2	75-90	16	6.90
8	6	3/4	4	75-90	25	9.05
10	8	3/4	4	75-90	30	11.10
12	8	3/4	4	75-90	40	13.20
14	10	3/4	4 1/2	75-90	45	15.30
16	12	3/4	4 1/2	75-90	55	17.40
18	12	3/4	4 1/2	75-90	65	19.50
20	14	3/4	4 1/2	75-90	85	21.60
24	16	3/4	5	75-90	105	25.80
30	20	1	6	100-120	220	32.00
36	24	1	6	100-120	301	38.30
42	28	1 1/4	6 1/2	120-150	389	44.50
48	32	1 1/4	6 1/2	120-150	477	50.80

C153 DUCTILE IRON COMPACT FITTINGS

SAMPLE SPECIFICATIONS

(Current ANSI/AWWA revisions apply)

Push-on joint ductile iron fittings size 4" through 24" shall be produced in accordance with all applicable terms and provisions of ANSI/AWWA C153/A21.53. Fittings are cement lined and seal coated in accordance with ANSI/AWWA C104/A21.4. Joints shall be in accordance with manufacturer's design with bell sockets designed to receive pressure pipe O.D.s as specified in ANSI/AWWA C151/A21.51 and AWWA C900 TABLE 2. The working pressure rating shall be 350 psi, except for wyes and flanged-branch fittings. NOTE: Fittings are cement lined and seal coated in accordance with ANSI/AWWA C104/A21.4, also available bare or epoxy coated. Double cement lined available. Coated and/or lined fittings meet NSF-61, NSF-372 and Annex G.

Thicknesses and dimensions of bell sockets and gaskets shall be in accordance with the manufacturer's design. Gaskets shall be furnished by the manufacturer. Working pressures apply to fittings only and do not apply to restraining lugs or external restraining devices. Installation of fittings shall be per AWWA C600 and AWWA C651, current revision.

NOTE: Standard restraining lugs are provided on sizes 4" through 16" ONLY. Restraining lugs are available on 18" through 24" fittings, provided sufficient time is available to make tooling adaptations.

EXCEPTIONS: Union-Tite fittings with flanged branches are rated for water pressure of 250 psi but can be rated for 350 psi with the use of an annular ring or comparable gasket. Wye fittings over 12" are not pressure rated. Call Tyler Union for information.

ADVANTAGES AND FEATURES NOTE:

- Push-on gasket joint uses TYTON® or McWane 350 Sure Stop® gaskets.
- For use with Ductile Iron Pipe, C-900/905 PVC pipe and 4" through 12" pressure-rated IPS diameter PVC pipe (with transition gasket).
- Deep stab joint design accommodates common spigot end taper on plastic pipes.
- Slip joint installation eliminates T-bolts and nuts (MJ glands not needed).

NOTE: TYTON is a registered trademark of U.S. Pipe and Foundry Company.

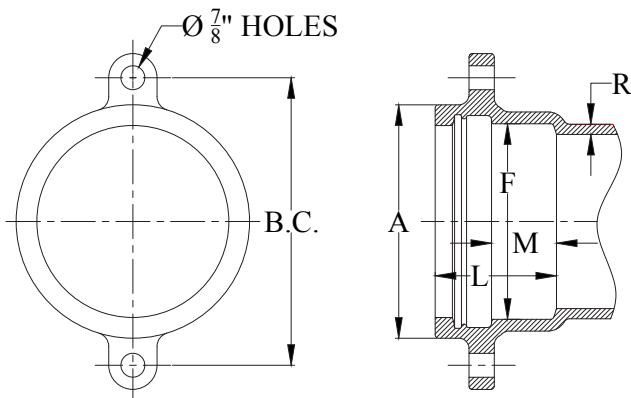

ANSI/AWWA C153 Push-On Joint Fittings

Nominal Joint Dimensions in Inches						
Size	F	A	B.C.	L	M	R
4	5.04	6.38	7.88	4.16	2.25	0.35
6	7.14	8.52	10.50	4.29	2.25	0.37
8	9.32	10.90	12.88	4.78	2.25	0.39
10	11.37	12.91	14.69	4.98	2.25	0.41
12	13.47	15.12	17.19	4.98	2.25	0.43
14	15.64	18.12	19.00	5.40	2.25	0.51
16	17.74	20.32	21.40	5.40	2.25	0.52
18	19.83	22.52	—	5.40	2.25	0.59
20	21.94	24.29	—	5.40	2.25	0.60
24	26.14	29.14	—	5.65	2.50	0.62

C153 DUCTILE IRON COMPACT FITTINGS

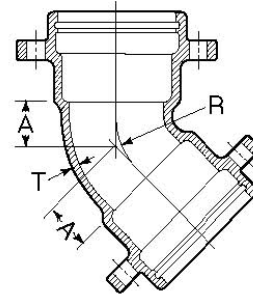
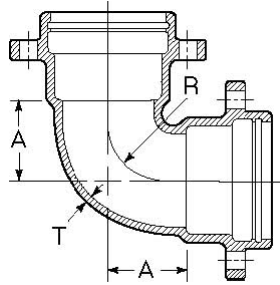

90° (1/4) UT Bends						45° (1/8) UT Bends					
Domestic					Import					Domestic	Import
Size	T	A	R	Weight	T	Weight	A	R	Weight	Weight	
4	0.35	4.00	3.87	24	0.34	25	2.00	3.31	26	22	
6	0.37	5.00	5.37	51	0.36	39	3.00	5.72	42	32	
8	0.39	6.50	6.37	80	0.38	57	3.50	6.93	66	46	
10	0.41	7.50	8.36	121	0.40	89	4.50	9.34	101	70	
12	0.43	9.00	9.36	151	0.42	108	5.50	11.75	128	86	
14	0.51	11.50	10.98	254	0.47	210	5.00	10.85	143	160	
16	0.52	12.50	12.00	328	0.50	264	5.50	12.02	225	202	
18	0.59	14.00	14.00	482	0.54	335	6.00	12.36	209	250	
20	0.60	15.00	15.50	340	0.57	400	7.00	13.59	397	305	
24	0.62	16.75	15.59	674	0.61	565	7.50	14.69	492	405	

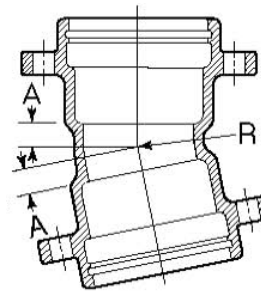
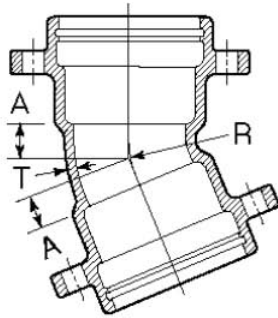

22½° (1/16) UT Bends			
		Domestic	Import
A	R	Weight	Weight
1.50	4.38	18	18
2.00	8.16	39	31
2.50	9.40	64	46
3.00	13.17	67	64
3.50	14.42	111	80
3.75	13.82	162	136
3.75	14.97	195	172
4.50	30.19	209	255
4.50	35.19	414	310
4.50	37.69	596	412

11¼° (1/32) UT Bends			
		Domestic	Import
A	R	Weight	Weight
1.25	6.77	18	16
1.50	9.38	40	30
1.75	11.48	60	42
2.00	13.95	77	58
2.25	16.5	94	67
2.50	14.26	113	93
2.50	15.23	172	148
3.00	60.94	209	205
3.00	71.07	265	245
-	-	-	315

C153 DUCTILE IRON COMPACT FITTINGS

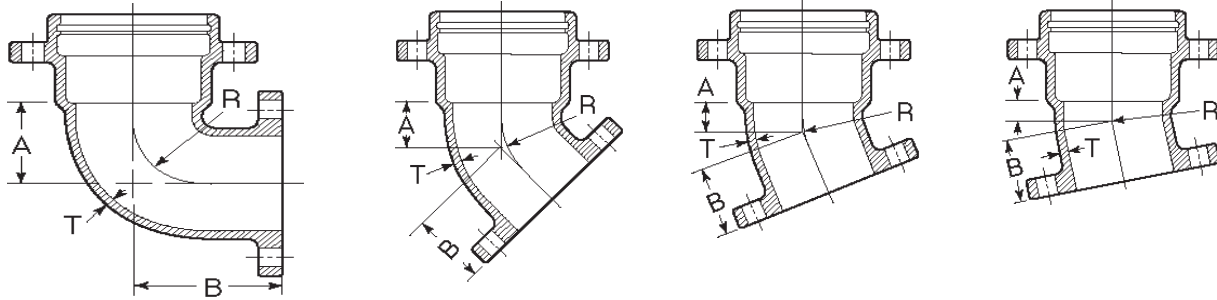

90° (1/4) UT x FE Bends						45° (1/8) UT x FE Bends				22 1/2° (1/16) UT x FE Bends				11 1/4° (1/32) UT x FE Bends			
Size	T	A	B	R	Weight	A	B	R	Weight	A	B	R	Weight	A	B	R	Weight
4	0.35	4.50	6.50	3.87	31	2.00	4.00	3.31	21	1.50	3.50	4.38	25	1.25	3.30	6.77	24
6	0.37	6.00	7.00	5.37	49	3.00	5.00	5.72	42	2.25	4.30	8.16	44	1.50	3.50	9.38	30
8	0.39	7.00	9.00	6.37	74	3.50	5.50	6.93	60	2.50	4.50	9.40	64	1.75	3.75	11.48	61
10	0.41	9.00	10.00	8.36	130	4.50	6.50	9.34	93	3.00	5.30	13.17	90	2.00	4.00	13.95	80
12	0.43	10.00	12.00	9.36	158	5.50	7.50	11.75	122	3.50	5.50	14.42	112	2.25	4.30	16.50	94
14	0.51	12.00	15.50	10.98	231	5.50	8.50	10.85	162	3.75	6.80	13.82	174	2.60	5.75	14.26	170
16	0.52	13.00	16.50	12.00	233	6.00	9.50	12.02	275	4.00	7.50	14.97	228	2.60	6.10	15.23	228

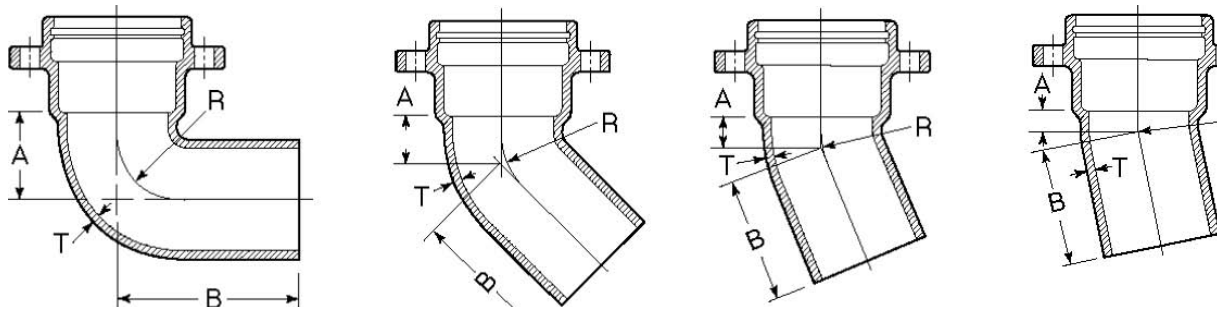

90° (1/4) UT x PE Bends						45° (1/8) UT x PE Bends				22 1/2° (1/16) UT x PE Bends				11 1/4° (1/32) UT x PE Bends			
Size	T	A	B	R	Weight	A	B	R	Weight	A	B	R	Weight	A	B	R	Weight
4	0.35	4.50	6.50	3.87	31	2.00	8.00	3.31	21	-	-	-	-	-	-	-	-
6	0.37	6.00	7.00	5.37	49	3.00	9.00	5.72	38	2.25	8.10	8.16	35	1.50	7.30	9.38	36
8	0.39	-	-	-	-	3.50	9.50	6.93	60	2.50	8.30	9.40	57	1.75	7.55	11.48	55

Tyler Union does not recommend the use of wedge action restraints on plain end fittings.

C153 DUCTILE IRON COMPACT FITTINGS

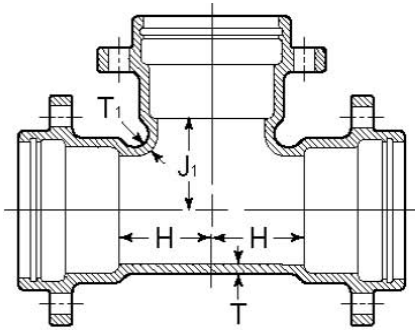

UTxUT Tee

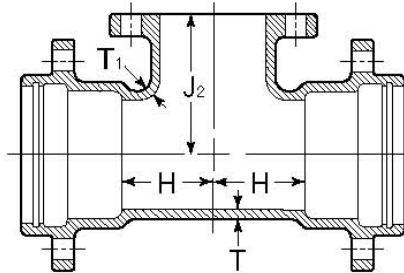

UTxFE Tee

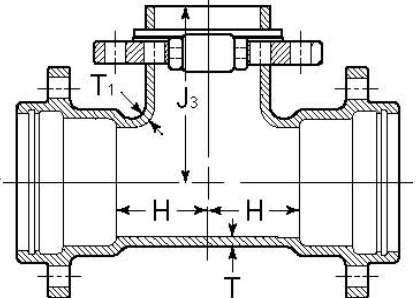

UTxSwivel Tee

TEES											
Size	T	T1	H	J1	J2	J3	Weight				
							UT x UT	UT x Flange	UT x PE	Crosses	
6x4	0.00	0.00	5.00	6.00	8.00	—	68	56	—	—	
8x4	0.00	0.00	5.00	7.00	9.00	—	73	89	—	—	
8x6	0.00	0.00	6.00	7.00	9.00	11.00	96	101	100	88	
8	0.00	0.00	7.00	7.00	9.00	11.00	116	117	110	—	
10x4	0.00	0.00	6.00	9.00	11.00	—	102	115	—	117	
10x6	0.00	0.00	7.00	9.00	11.00	13.00	113	128	130	156	
10x8	0.00	0.00	8.00	9.00	11.00	13.00	145	145	156	116	
10	0.00	0.00	9.00	9.00	11.00	—	155	158	—	—	
12x4	0.00	0.00	6.00	10.00	12.00	—	119	138	—	—	
12x6	0.00	0.00	7.00	10.00	12.00	14.00	141	148	162	—	
12x8	0.00	0.00	8.00	10.00	12.00	14.00	177	170	158	—	
12x10	0.00	0.00	9.00	10.00	12.00	—	160	162	—	240	
12	0.00	0.00	10.00	10.00	12.00	—	217	183	—	—	
14x6	1.00	0.00	7.00	11.00	13.00	14.00	176	212	202	241	
14x10	1.00	0.00	9.00	11.00	13.00	—	195	246	—	189	
14x12	1.00	0.00	10.00	11.00	13.00	—	196	296	—	204	
14	1.00	1.00	11.00	11.00	14.00	—	209	321	—	222	
16x6	1.00	0.00	7.00	12.00	14.00	15.00	266	160	229	239	
16x8	1.00	0.00	8.00	12.00	14.00	15.00	292	270	292	270	
16x10	1.00	0.00	9.00	12.00	14.00	—	232	330	—	234	
16x12	1.00	0.00	10.00	12.00	14.00	—	239	321	—	323	
16x14	1.00	1.00	11.00	12.00	15.00	—	349	342	—	268	
16	1.00	1.00	12.00	12.00	15.00	—	261	355	—	274	
18x6	1.00	0.00	7.00	13.00	15.00	16.00	348	301	348	322	
18x8	1.00	0.00	8.00	13.00	15.00	16.00	325	319	324	317	
18x10	1.00	0.00	9.00	13.00	15.00	—	344	337	—	—	
18x14	1.00	1.00	11.00	13.00	16.00	—	342	393	—	—	
18x16	1.00	1.00	12.00	13.00	16.00	—	362	420	—	—	
20x6	1.00	0.00	7.00	14.00	16.00	18.00	355	341	400	—	
20x10	1.00	0.00	9.00	14.00	16.00	—	369	420	—	—	
20x14	1.00	1.00	11.00	14.00	18.00	—	484	474	—	—	
20x16	1.00	1.00	12.00	14.00	18.00	—	610	498	—	—	
20x18	1.00	1.00	13.00	14.00	18.00	—	539	—	—	—	
24x6	1.00	0.00	7.00	16.00	18.00	20.00	385	512	525	—	
24x10	1.00	0.00	9.00	16.00	18.00	—	478	468	—	—	
24x12	1.00	0.00	10.00	16.00	18.00	—	663	503	—	—	
24x14	1.00	1.00	11.00	16.00	20.00	—	542	531	—	—	
24x16	1.00	1.00	12.00	16.00	20.00	—	566	555	—	—	
24x18	1.00	1.00	13.00	16.00	—	—	593	—	—	—	
24x20	1.00	1.00	15.00	17.00	—	—	628	—	—	—	
24	1.00	1.00	17.00	17.00	—	—	884	—	—	—	

C153 DUCTILE IRON COMPACT FITTINGS

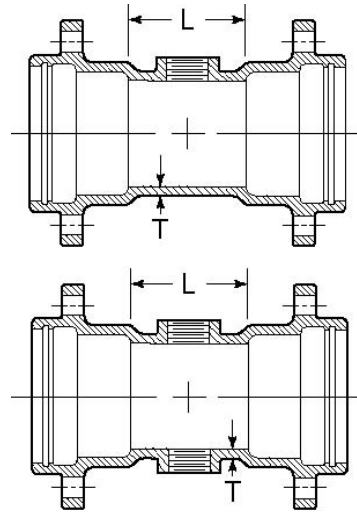
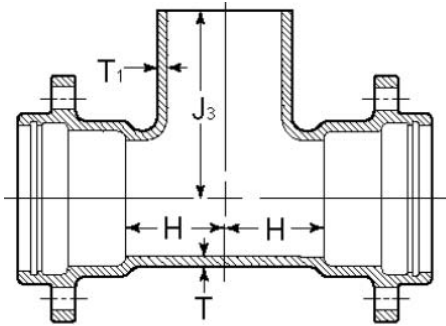

UT X UT X PE TEES						
Size		T	T1	H	J3	Weight
Run	Branch					
6	6	0.37	0.37	6.00	11.50	60
8	6	0.39	37.00	6.00	12.50	80
12	6	0.43	0.37	7.00	15.50	140

Tyler Union does not recommend the use of wedge action restraints on plain end fittings.

TAPPED TEES / CROSSES					
Size	A	B	C	D	
4	0.35	3.00	6.00	27.00	
6	0.37	3.50	6.00	38.00	
8	0.39	3.50	6.00	59.00	
10	0.41	3.50	6.00	72.00	
12	0.43	3.50	6.00	92.00	

WYES

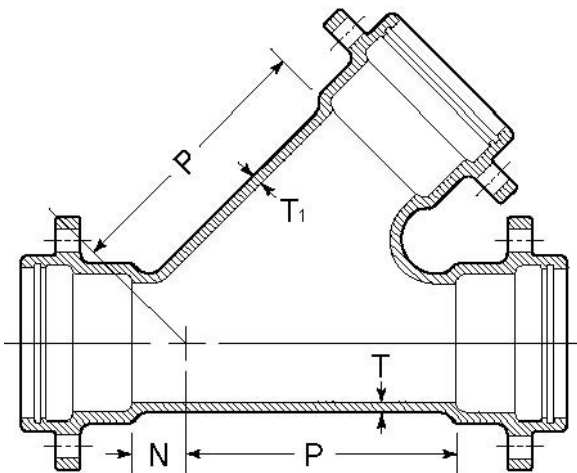

UT WYE					
Size	T	T1	P	N	Weight
8x4	0.39	0.35	13.50	0.00	89
10x4	0.41	0.35	15.00	0.00	141
10x6	0.41	0.37	16.00	1.00	151
10x8	0.41	0.39	17.00	2.50	175
10	0.41	0.41	18.00	4.00	200
12x4	0.43	0.35	16.50	0.00	178
12x6	0.43	0.37	18.50	1.50	201
12x8	0.43	0.39	18.50	1.50	224
12x10	0.43	0.41	20.00	3.00	240
12	0.43	0.43	20.00	5.00	289
14x6	0.51	0.44	19.50	0.00	236
14x8	0.51	0.45	21.00	1.50	255
14x10	0.51	0.46	22.50	3.00	325
14	0.51	0.51	25.00	6.00	475
16x6	0.52	0.45	21.00	0.00	281
16x8	0.52	0.46	22.50	0.50	304
16x12	0.52	0.48	25.00	3.50	346
16	0.52	0.52	28.00	6.50	380



C153 DUCTILE IRON COMPACT FITTINGS

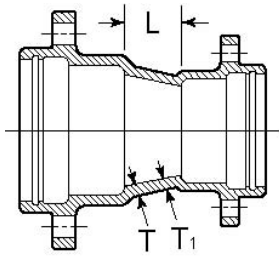

UTxUT Reducer

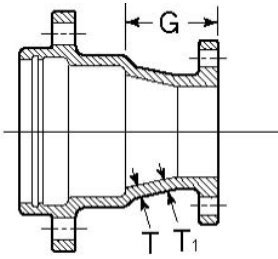

UTxFE Reducer

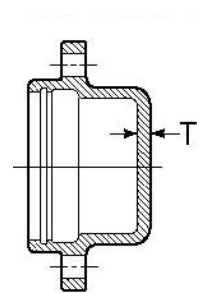

Solid Cap

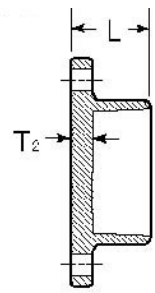

Solid Plug

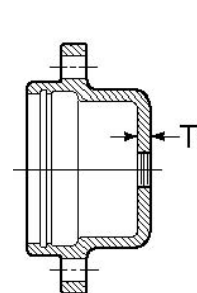

Tapped Cap

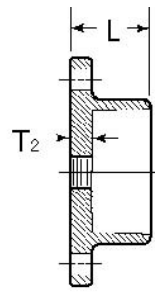

Tapped Plug

REDUCERS						
Size	T	T1	L	G	Weight	
					UT x UT	UT x Flange
6x4	0.37	0.35	4.00	6.00	32	32
8x4	0.39	0.35	5.00	7.00	46	46
8x6	0.39	0.37	4.00	6.00	49	47
10x4	0.41	0.35	7.00	9.00	47	55
10x6	0.41	0.37	5.00	7.00	47	59
10x8	0.41	0.39	4.00	6.00	53	61
12x4	0.43	0.35	9.00	11.00	74	78
12x6	0.43	0.37	7.00	9.00	58	75
12x8	0.43	0.39	5.00	7.00	74	74
12x10	0.43	0.41	4.00	6.00	82	95
14x6	0.51	0.44	9.00	11.00	84	121
14x8	0.51	0.45	7.00	9.00	85	128
14x10	0.51	0.46	5.00	7.00	87	127
14x12	0.51	0.47	4.00	6.00	104	144
16x6	0.52	0.45	11.00	13.00	94	133
16x8	0.52	0.46	9.00	11.00	104	141
16x10	0.52	0.47	7.00	9.00	130	158
16x12	0.52	0.48	5.00	7.00	152	172
16x14	0.52	0.51	4.00	6.00	139	196
18x8	0.59	0.45	14.00	16.00	142	157
18x10	0.59	0.47	12.00	14.00	151	175
18x12	0.59	0.49	10.00	12.00	167	215
18x14	0.59	0.56	8.00	11.50	217	234
18x16	0.59	0.57	7.00	10.50	202	246
20x10	0.60	0.47	14.00	16.00	180	234
20x12	0.60	0.49	12.00	-	205	-
20x14	0.60	0.56	10.00	13.50	233	249
20x16	0.60	0.57	8.00	11.50	250	272
20x18	0.60	0.59	7.00	-	248	-
24x12	0.62	0.49	16.00	18.00	246	262
24x14	0.62	0.56	14.00	17.50	281	315
24x16	0.62	0.57	12.00	15.50	380	328
24x18	0.62	0.59	10.00	-	390	-
24x20	0.62	0.60	8.00	-	421	-

UT CAPS & PLUGS					
Size	T1	T2	L	Weight	
				Cap	Plug
4	0.48	0.50	5.30	15	8.0
6	0.48	0.50	5.30	20	23.0
8	0.51	0.50	5.30	35	32.0
10	0.53	0.60	5.30	50	38.0
12	0.55	0.60	5.30	75	49.0

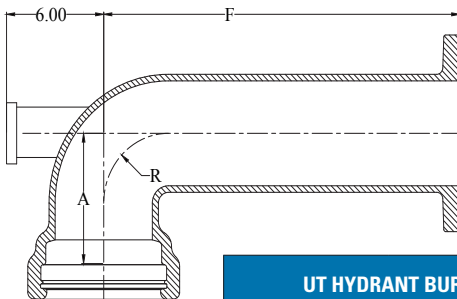
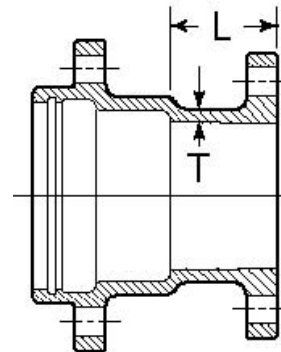

UT HYDRANT BURY

Size	A	F	R
6x42	7.50	42.00	4.00

Note: Please specify 8-bolt-hole flange or 6-bolt-hole flange upon order placement.

UT x Flange ADAPTER			
Size	T1	T2	Weight
4	0.00	6.00	28
6	0.00	6.00	36
8	0.00	6.00	54
10	0.00	6.00	71
12	0.00	6.00	102
14	1.00	7.00	113
16	1.00	7.00	115
20	1.00	6.00	295

C110 DUCTILE IRON FULL BODY FITTINGS

SAMPLE SPECIFICATIONS

(Current ANSI/AWWA revisions apply)

Flanged fittings, 2” through 64”, shall be manufactured of ductile iron in accordance with all applicable terms and provisions of standards ANSI/AWWA C110/A21.10. Flange surfaces shall be faced and drilled in accordance with ANSI Class 125, B16.1. All ductile iron flanged fittings shall be rated for water pressure of 250 psi. Flanged ductile iron fittings in 4” through 24” may be rated for 350 psi (2,413 kPa) with the use of special gaskets.

NOTE: Fittings are available prime coated, bare or epoxy coated. All coated fittings meet requirements of NSF-61, NSF-372 and Annex G. Interiors of fittings shall be lined and seal coated in accordance with ANSI/AWWA C104/A21.4. Installation of fittings shall be per AWWA C110.

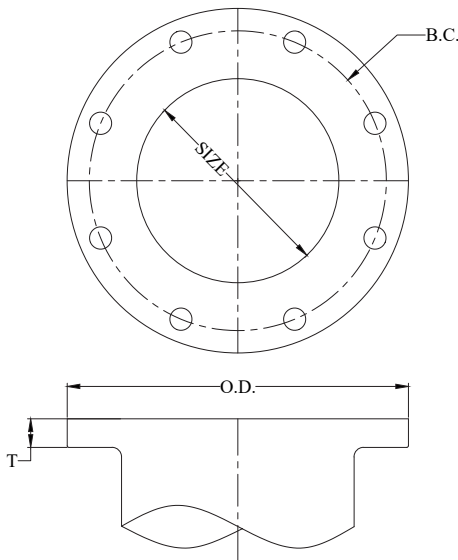

ANSI/AWWA C110 Class 125 Flange Fittings

FLANGE DETAILS						
Nominal Pipe Size Inch	Flange O.D.	B.C. Diameter	Flange Thickness T	Bolt Hole Diameter	Number of Bolts	Bolt Dia. and Lengths
2	6.00	4.75	0.62	0.750	4	5/8 x 2 1/4
3	7.50	6.00	0.75	0.750	4	5/8 x 2 1/2
4	9.00	7.50	0.94	0.750	8	5/8 x 3
6	11.00	9.50	1.00	0.880	8	3/4 x 3 1/2
8	13.50	11.75	1.12	0.880	8	3/4 x 3 1/2
10	16.00	14.25	1.19	1.000	12	7/8 x 4
12	19.00	17.00	1.25	1.000	12	7/8 x 4
14	21.00	18.75	1.38	1.130	12	1 x 4 1/2
16	23.50	21.25	1.44	1.130	16	1 x 4 1/2
18	25.00	22.75	1.56	1.250	16	1 1/8 x 5
20	27.50	25.00	1.69	1.250	20	1 1/8 x 5
24	32.00	29.50	1.88	1.375	20	1 1/4 x 5 1/2
30	38.75	36.00	2.12	1.375	28	1 1/4 x 6 1/2
36	46.00	42.75	2.38	1.625	32	1 1/2 x 7
42	53.00	49.50	2.62	1.625	36	1 1/2 x 7 1/2
48	59.50	56.00	2.75	1.625	44	1 1/2 x 8
54	66.25	62.75	3.00	2.00	44	1 3/4 x 8 1/2
60	73.00	69.25	3.12	2.00	52	1 3/4 x 9
64	80.00	76.00	3.38	2.00	52	1 3/4 x 9

Contact Tyler Union for 54”–64” flange fitting information.

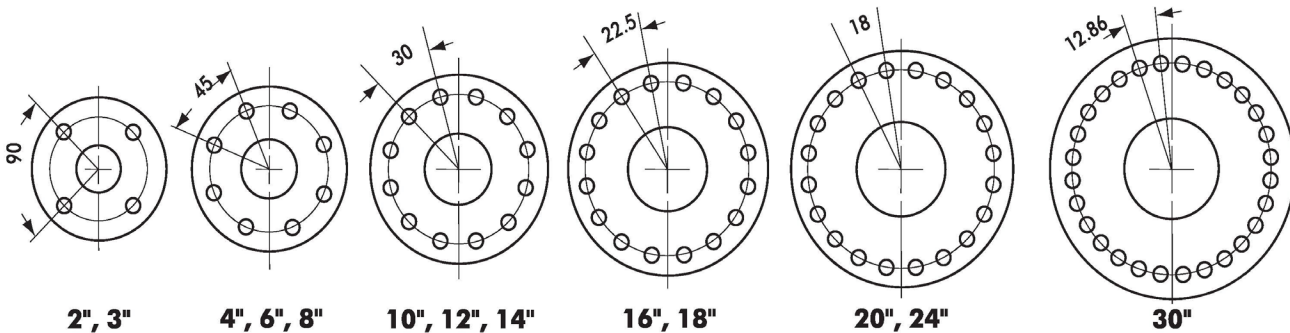

NOTE: Drilling templates are in multiples of four so that fittings may be made to face in any quarter. Bolt holes shall straddle the center line.

C110 DUCTILE IRON FULL BODY FITTINGS

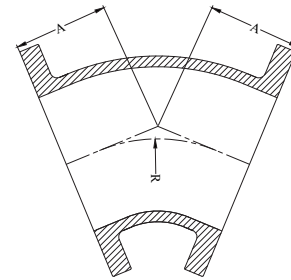
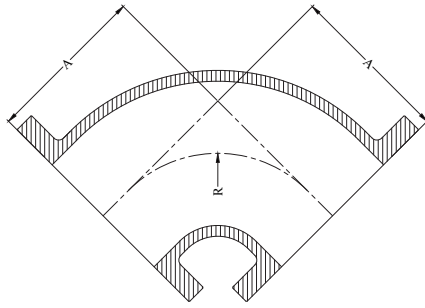

90° (1/4) BENDS				
Size	R	A	Domestic	Import
			Weight	Weight
2	3.00	4.50	14	—
3	4.00	5.50	26	25
4	4.50	6.50	44	45
6	6.00	8.00	67	65
8	7.00	9.00	115	105
10	9.00	11.00	159	165
12	10.00	12.00	244	235
14	11.50	14.00	341	290
16	12.50	15.00	455	370
18	14.00	16.50	527	450
20	15.50	18.00	878	580
24	18.50	22.00	1085	900
30	21.50	25.00	1427	1430
36	24.50	28.00	2135	2135
42	27.50	31.00	3055	3055
48	30.50	34.00	4095	4095

45° (1/8) BENDS				
Size	R	A	Domestic	Import
			Weight	Weight
2	—	—	—	—
3	3.62	3.00	20	20
4	4.81	4.00	36	40
6	7.25	5.00	57	55
8	8.44	5.50	105	90
10	10.88	6.50	127	130
12	13.25	7.50	149	195
14	12.06	7.50	260	220
16	13.25	8.00	322	280
18	14.50	8.50	371	325
20	16.88	9.50	485	430
24	18.12	11.00	742	630
30	27.75	15.00	1355	1120
36	35.00	18.00	1755	1755
42	42.25	21.00	2600	2600
48	49.50	24.00	3580	3580

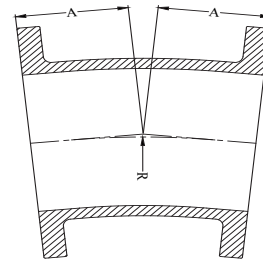
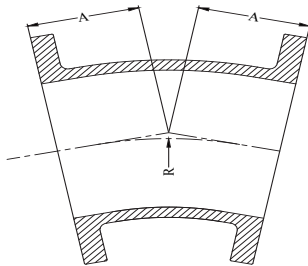

22½° (1/16) BENDS				
Size	R	A	Domestic	Import
			Weight	Weight
2	—	—	—	—
3	7.56	3.00	22	20
4	10.06	4.00	35	40
6	15.06	5.00	64	55
8	17.62	5.50	90	90
10	22.62	6.50	130	135
12	27.67	7.50	199	205
14	25.12	7.50	281	225
16	27.62	8.00	315	285
18	30.19	8.50	402	335
20	35.19	9.50	543	435
24	37.69	11.00	528	640
30	57.81	15.00	1385	1135
36	72.88	18.00	1790	1790
42	88.00	21.00	2665	2663
48	103.06	24.00	3665	3665

11¼° (1/32) BENDS				
Size	R	A	Domestic	Import
			Weight	Weight
2	—	—	—	—
3	15.25	3.00	20	20
4	20.31	4.00	40	40
6	30.50	5.00	56	55
8	35.50	5.50	90	90
10	45.69	6.50	136	135
12	55.81	7.50	213	205
14	50.75	7.50	261	225
16	55.81	8.00	315	285
18	60.94	8.50	385	335
20	71.06	9.50	505	435
24	76.12	11.00	760	645
30	116.75	15.00	1395	1150
36	147.25	18.00	1805	1805
42	177.69	21.00	2680	2680
48	208.12	24.00	3695	3695

C110 DUCTILE IRON FULL BODY FITTINGS

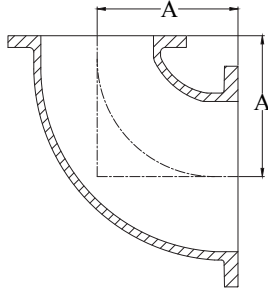

90° REDUCING BEND (1/4)		
Size	A	Weight
4x3	6.50	35
6x4	8.00	65
8x4	9.00	88
8x6	9.00	96
10x6	11.00	126
10x8	11.00	151
12x6	12.00	172
12x8	12.00	191
12x10	12.00	218
14x6	14.00	230
14x8	14.00	240
16x10	15.00	280

*Not included in AWWA C110. Contact Tyler Union for sizes not shown.

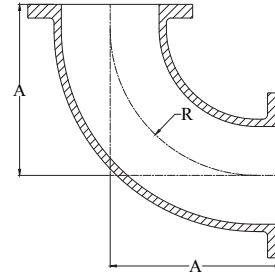

90° LONG RADIUS BEND (1/4)			
Size	R	A	Weight
3	6.25	7.75	32
4	7.00	9.00	46
6	9.50	11.50	83
8	12.00	14.00	140
10	14.50	16.50	252
12	17.00	19.00	310
14	19.00	21.50	475
16	21.50	24.00	630
18	—	26.50	840
20	—	29.00	1080
24	—	34.00	1640

*Not included in AWWA C110. Contact Tyler Union for sizes not shown.

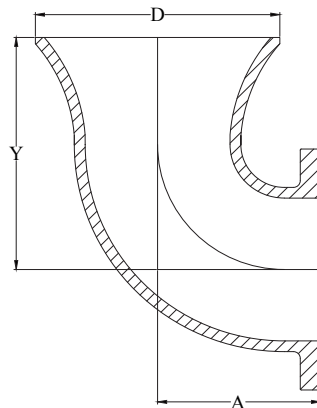

FLANGE AND FLARE 90° BEND (1/4)				
Size	D	A	Y	Weight
3	8.00	5.50	8.50	26
4	9.00	6.50	9.50	39
6	11.00	8.00	12.00	73
8	14.00	9.00	13.00	110
10	16.00	11.00	15.00	171
12	19.00	12.00	16.00	253
14	21.00	14.00	21.50	450
16	24.00	15.00	23.00	545
18	25.00	16.50	24.50	675
20	28.00	18.00	26.00	860
24	32.00	22.00	30.00	1195
30	39.00	25.00	38.00	2070
36	48.00	28.00	38.00	2900

C110 DUCTILE IRON FULL BODY FITTINGS

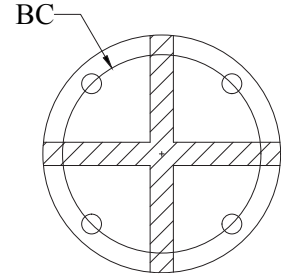
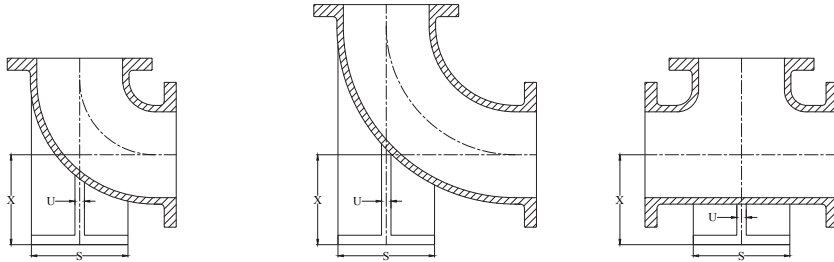

90° BASE BENDS			90° LONG RADIUS BASE BEND		BASE TEES			
Size	X	S	U	Support Pipe size	Weight			
					90°	90° L R	Tee	90°
3	4.88	5.00	0.50	1.50	38	41	47	35
4	5.50	6.00	0.50	2.00	50	60	76	55
6	7.00	7.00	0.62	2.50	83	100	115	85
8	8.38	9.00	0.88	4.00	142	180	195	145
10	9.75	9.00	0.88	4.00	210	315	315	145
12	11.25	11.00	1.00	6.00	300	427	450	300
14	12.50	11.00	1.00	6.00	400	580	570	360
16	13.75	11.00	1.00	6.00	505	740	710	445
18	15.00	13.50	1.12	8.00	645	—	900	565
20	16.00	13.50	1.12	8.00	805	—	1125	700
24	18.50	13.50	1.12	8.00	1215	—	1927	1030
30	23.00	16.00	1.15	10.00	1945	—	—	1625
36	26.00	19.00	1.15	12.00	2395	2895	—	2385
42	30.00	23.50	1.28	—	—	—	—	3465
48	34.00	25.00	1.42	—	—	—	—	4610

BASE DRILLING DETAILS			
Size	BC	Bolt Hole Diameter	No of Holes
3	3.88	5/8	4
4	4.75	3/4	4
6	5.50	3/4	4
8	7.50	3/4	4
10	7.50	3/4	4
12	9.50	7/8	4
14	9.50	7/8	4
16	9.50	7/8	4
18	11.75	7/8	4
20	11.75	7/8	4
24	11.75	7/8	4
30	14.25	1	4
36	17.00	1	4
42	21.25	1 1/8	4
48	22.75	1 1/4	4

Base bends are made to order only and not returnable. Bases are furnished faced and drilled.

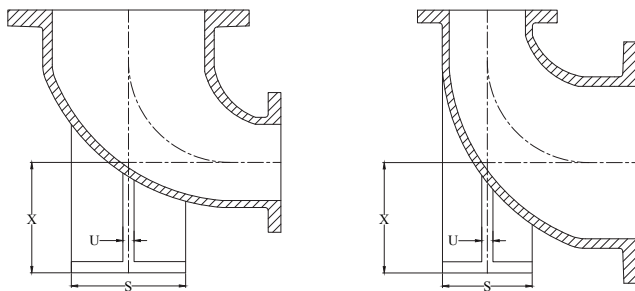

Base Under Large End

Base Under Small End

BASE				
Size	X	S	U	Weight
4x3	5.50	6.00	0.50	45
6x4	7.00	8.50	0.62	75
8x4	8.38	9.00	0.88	118
8x6	8.38	9.00	0.88	135
10x6	9.75	9.00	0.88	175
10x8	9.75	9.00	0.88	184
12x6	11.25	11.00	1.00	230
12x8	11.25	11.00	1.00	255

Note: X dimensions are identical on Base Under Large End & Base Under Small End. S dimension is determined by the largest fitting opening.

C110 DUCTILE IRON FULL BODY FITTINGS

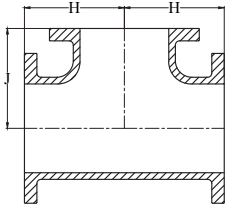

Straight Tees, Reducing on Branch Tees

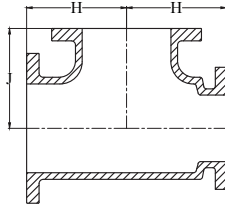

*Reducing on Run

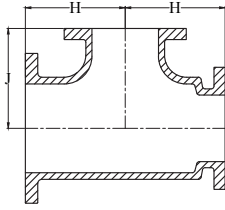

*Reducing on Run and Branch

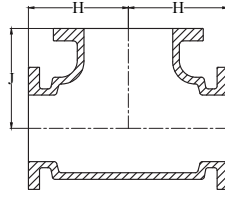

*Bullhead Tees

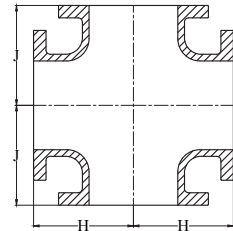

Straight and Reducing Crosses

TEES AND CROSSES									
Sizes					Domestic Weight		Import Weight		
Run	Run	Branch	H	J	Tee	Cross	Tee	Cross	
2	2	2	4.50	4.50	20	—	—	—	
3	3	2	5.50	5.50	35	—	—	—	
3	3	3	5.50	5.50	42	51	40	50	
4	3	3	6.50	5.50	53	—	—	—	
4	4	2	6.50	6.50	55	—	—	—	
4	4	3	6.50	6.50	54	76	60	70	
4	4	4	6.50	6.50	60	—	65	80	
4	4	6	8.00	8.00	88	—	—	—	
*6	4	4	8.00	8.00	85	—	—	—	
6	6	8	9.00	9.00	90	112	85	95	
6	6	4	8.00	8.00	90	141	90	110	
6	6	6	8.00	8.00	98	125	95	120	
*8	6	4	9.00	9.00	130	—	—	—	
*8	6	8	9.00	9.00	154	—	—	—	
8	8	3	9.00	9.00	128	140	—	—	
8	8	4	9.00	9.00	155	155	140	155	
8	8	6	9.00	9.00	148	172	145	165	
8	8	8	9.00	9.00	179	195	155	195	
*8	8	10	11.00	11.00	225	—	—	—	
*8	8	12	12.00	12.00	277	—	—	—	
*†10	6	6	13.00	13.00	278	—	—	—	
*†10	8	6	13.00	13.00	298	—	—	—	
*†10	8	8	13.00	13.00	278	—	—	—	
*†10	8	10	13.00	13.00	325	—	—	—	
10	10	4	11.00	11.00	239	220	205	220	
10	10	6	11.00	11.00	215	242	215	240	
10	10	8	11.00	11.00	254	294	225	265	
10	10	10	11.00	11.00	265	—	270	330	
10	10	12	12.00	12.00	337	—	—	—	
*†12	6	6	14.00	14.00	346	—	—	—	
*†12	6	8	14.00	14.00	362	—	—	—	
*†12	8	6	14.00	14.00	355	—	—	—	
*12	8	8	12.00	12.00	375	—	—	—	
*12	8	12	14.00	14.00	420	—	—	—	
*†12	10	6	14.00	14.00	390	—	—	—	
12	10	8	12.00	12.00	400	—	—	—	
12	10	10	12.00	12.00	420	—	—	—	
12	10	12	12.00	12.00	440	—	—	—	

* Not included in AWWA C110.

† H and J dimensions are two inches longer than straight tees.

C110 DUCTILE IRON FULL BODY FITTINGS

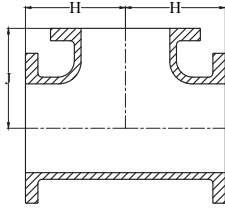

Straight Tees, Reducing on Branch Tees

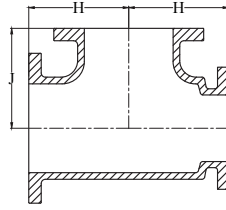

*Reducing on Run

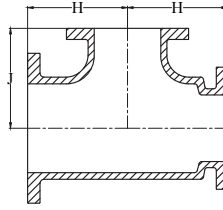

*Reducing on Run and Branch

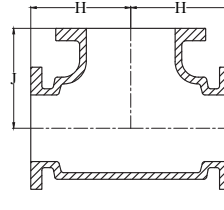

*Bullhead Tees

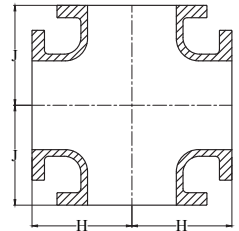

Straight and Reducing Crosses

TEES AND CROSSES								
Sizes					Domestic Weight		Import Weight	
Run	Run	Branch	H	J	Tee	Cross	Tee	Cross
12	12	4	12.00	12.00	322	310	290	—
12	12	6	12.00	12.00	297	326	295	—
12	12	8	12.00	12.00	346	351	310	—
12	12	10	12.00	12.00	394	415	360	—
12	12	12	12.00	12.00	369	438	385	—
*14	14	4	14.00	14.00	410	—	—	—
14	14	6	14.00	14.00	420	450	375	—
14	14	8	14.00	14.00	435	475	390	—
14	14	10	14.00	14.00	450	—	400	—
14	14	12	14.00	14.00	470	555	425	—
*14	14	14	14.00	14.00	500	595	435	—
*16	*14	4	15.00	15.00	525	—	—	—
16	*16	6	15.00	15.00	573	565	465	490
16	16	8	15.00	15.00	555	590	475	520
16	16	10	15.00	15.00	565	620	495	555
16	16	12	15.00	15.00	590	665	520	605
16	16	14	15.00	15.00	610	—	530	620
16	16	16	15.00	15.00	635	755	550	665
18	18	6	13.00	15.50	780	—	480	505
18	18	8	13.00	15.50	609	—	495	535
18	18	10	13.00	15.50	585	—	510	560
18	18	12	13.00	15.50	638	706	535	610
18	18	14	16.50	16.50	808	—	630	720
18	18	16	16.50	16.50	760	—	650	765
18	18	18	16.50	16.50	865	915	665	795
20	20	6	14.00	17.00	773	—	610	635
20	20	8	14.00	17.00	720	—	620	665
20	20	10	14.00	17.00	735	—	635	685
20	20	12	14.00	17.00	816	820	660	735
20	20	14	14.00	17.00	770	—	665	745
20	20	16	18.00	18.00	950	1065	810	915
20	20	18	18.00	18.00	965	—	820	945
20	20	20	18.00	18.00	1005	1175	855	1015
24	24	6	15.00	19.00	1089	—	845	875
24	24	8	15.00	19.00	1060	—	860	895
24	24	10	15.00	19.00	1020	—	88	930
24	24	12	15.00	19.00	1125	1100	890	960
24	24	14	15.00	19.00	1050	1125	900	975
24	24	16	15.00	19.00	1070	1160	915	1010
24	24	18	22.00	22.00	1534	—	1220	1365
24	24	20	22.00	22.00	1510	1695	1255	1430
24	24	24	22.00	22.00	1685	1850	1330	1570

* Not included in AWWA C110.

C110 DUCTILE IRON FULL BODY FITTINGS

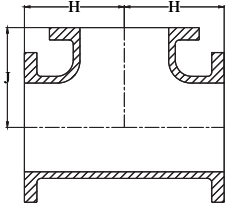

Straight Tees, Reducing on Branch Tees

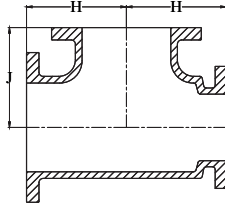

*Reducing on Run

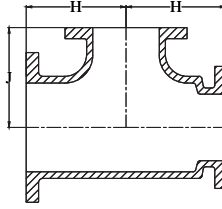

*Reducing on Run and Branch

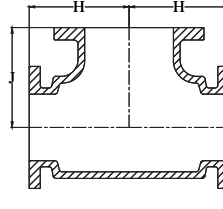

*Bullhead Tees

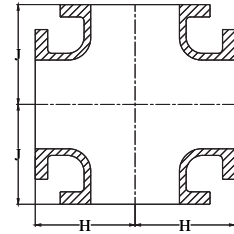

Straight and Reducing Crosses

TEES AND CROSSES								
Sizes					Domestic Weight		Import Weight	
Run	Run	Branch	H	J	Tee	Cross	Tee	Cross
30	30	6	18.00	23.00	1725	—	—	—
30	30	8	18.00	23.00	—	—	1490	1565
30	30	10	18.00	23.00	—	—	1490	1565
30	30	12	18.00	23.00	1801	—	1490	1565
30	30	14	18.00	23.00	—	—	1490	1570
30	30	16	18.00	23.00	—	—	1505	1605
30	30	18	18.00	23.00	1852	—	1515	1615
30	30	20	18.00	23.00	—	—	1540	1670
30	30	24	25.00	25.00	2475	2695	2025	2245
30	30	30	25.00	25.00	2615	2985	2150	2500
36	36	12	20.00	26.00	—	—	2170	2240
36	36	14	20.00	26.00	—	—	2175	2240
36	36	16	20.00	26.00	—	—	2185	2270
36	36	18	20.00	26.00	—	—	2190	2280
36	36	20	20.00	26.00	—	—	2210	2325
36	36	24	20.00	26.00	2255	—	2255	2405
36	36	30	28.00	28.00	3000	—	3000	3300
36	36	36	28.00	28.00	3160	6740	3160	3620
42	42	12	23.00	30.00	—	—	3165	3200
42	42	14	23.00	30.00	—	—	3170	3200
42	42	16	23.00	30.00	—	—	3180	3270
42	42	18	23.00	30.00	—	—	3185	3300
42	42	20	23.00	30.00	—	—	3205	3320
42	42	24	23.00	30.00	3245	—	3245	3395
42	42	30	31.00	31.00	4125	—	4125	4375
42	42	36	31.00	31.00	5360	—	5360	5720
42	42	42	31.00	31.00	5580	—	5585	6155
48	48	12	26.00	34.00	—	—	4315	4390
48	48	14	26.00	34.00	—	—	4315	4385
48	48	16	26.00	34.00	—	—	4330	4415
48	48	18	26.00	34.00	—	—	4330	4420
48	48	20	26.00	34.00	—	—	4350	4460
48	48	24	26.00	34.00	4385	—	4385	4535
48	48	30	26.00	34.00	4455	—	4455	4670
48	48	36	34.00	34.00	5555	—	5555	5880
48	48	42	34.00	34.00	7195	—	7195	9630
48	48	48	34.00	34.00	7385	—	7385	8005

* Not included in AWWA C110.

C110 DUCTILE IRON FULL BODY FITTINGS

CONCENTRIC REDUCER				
			Domestic	Import
D	D1	L	Weight	Weight
3.00	2.00	6.00	17	-
4.00	2.00	7.00	23	-
4.00	3.00	7.00	29	30
6.00	2.00	9.00	30	-
6.00	3.00	9.00	44	40
6.00	4.00	9.00	46	45
6.00	5.00	9.00	56	-
8.00	3.00	11.00	61	65
8.00	4.00	11.00	63	-
8.00	5.00	11.00	70	-
8.00	6.00	11.00	75	75
10.00	4.00	12.00	98	85
10.00	6.00	12.00	107	90
10.00	8.00	12.00	116	110
12.00	4.00	14.00	119	120
12.00	6.00	14.00	130	130
12.00	8.00	14.00	152	145
12.00	10.00	14.00	178	170
14.00	6.00	16.00	165	155
14.00	8.00	16.00	185	175
14.00	10.00	16.00	205	190
14.00	12.00	16.00	235	220
16.00	6.00	18.00	210	190
16.00	8.00	18.00	230	210
16.00	10.00	18.00	255	235
16.00	12.00	18.00	285	265
16.00	14.00	18.00	315	280
18.00	8.00	19.00	265	240
18.00	10.00	19.00	290	265
18.00	12.00	19.00	320	295
18.00	14.00	19.00	350	310
18.00	16.00	19.00	405	340
20.00	10.00	20.00	418	-
20.00	12.00	20.00	465	345
20.00	14.00	20.00	430	355
20.00	16.00	20.00	445	390
20.00	18.00	20.00	470	410
24.00	12.00	24.00	608	480
24.00	14.00	24.00	565	490
24.00	16.00	24.00	610	525
24.00	18.00	24.00	645	550
24.00	20.00	24.00	695	590
30.00	16.00	30.00	945	-
30.00	18.00	30.00	970	810
30.00	20.00	30.00	1144	870
30.00	24.00	30.00	1155	970
36.00	20.00	36.00	-	1230
36.00	24.00	36.00	-	1345
36.00	30.00	36.00	-	1555
42.00	24.00	42.00	1810	1820
42.00	30.00	42.00	2060	2060
42.00	36.00	42.00	-	2345
48.00	30.00	48.00	2615	2625
48.00	36.00	48.00	2940	2950
48.00	42.00	48.00	3320	3320

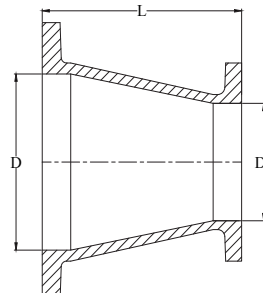

Concentric Reducer

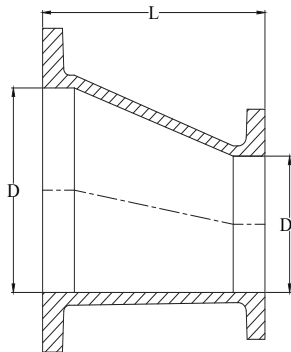

Eccentric Reducer

*ECCENTRIC REDUCER				
			Domestic	Import
D	D1	L	Weight	Weight
4.00	3.00	7.00	30	-
6.00	3.00	9.00	45	-
6.00	4.00	9.00	52	45
8.00	4.00	11.00	70	-
8.00	6.00	11.00	80	-
10.00	4.00	12.00	95	-
10.00	6.00	12.00	98	-
10.00	8.00	12.00	123	-
12.00	4.00	14.00	120	-
12.00	6.00	14.00	135	-
12.00	8.00	14.00	149	-
12.00	10.00	14.00	177	-
14.00	6.00	16.00	165	-
14.00	8.00	16.00	185	-
14.00	10.00	16.00	205	-
14.00	12.00	16.00	294	-
16.00	6.00	18.00	210	-
16.00	8.00	18.00	230	-
16.00	10.00	18.00	255	-
16.00	12.00	18.00	285	-
16.00	14.00	18.00	315	-
18.00	8.00	19.00	265	-
18.00	10.00	19.00	290	-
18.00	12.00	19.00	306	-
18.00	14.00	19.00	350	-
18.00	16.00	19.00	385	-
20.00	10.00	20.00	350	-
20.00	12.00	20.00	370	-
20.00	14.00	20.00	402	-
20.00	16.00	20.00	449	-
20.00	18.00	20.00	455	-
24.00	12.00	24.00	535	-
24.00	14.00	24.00	570	-
24.00	16.00	24.00	614	-
24.00	18.00	24.00	645	-
24.00	20.00	24.00	695	-
30.00	16.00	30.00	778	-
30.00	18.00	30.00	810	-
30.00	20.00	30.00	870	-
30.00	24.00	30.00	970	-
36.00	24.00	36.00	1425	-
36.00	30.00	36.00	2120	-
42.00	24.00	42.00	2340	-
42.00	30.00	42.00	2060	-
42.00	36.00	42.00	2345	-
48.00	30.00	48.00	2625	-
48.00	36.00	48.00	2950	-
48.00	42.00	48.00	3320	-

*Eccentric Reducers not included in AWWA C110.

C110 DUCTILE IRON FULL BODY FITTINGS

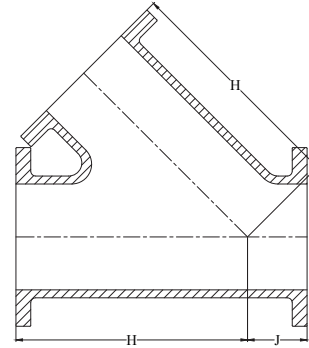
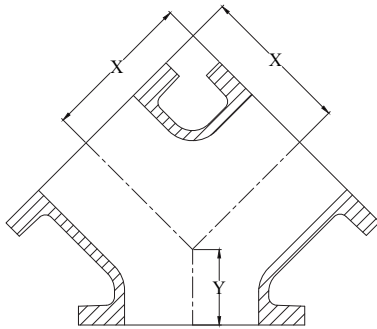

*TRUE WYES				
Sizes				Domestic
Stem	Branch	X	Y	Weight
4	4	6.50	3.00	49
6	4	8.00	3.50	75
6	6	8.00	3.50	84
8	6	9.00	4.50	134
8	8	9.00	4.50	125
10	6	8.00	5.00	140
10	8	9.00	5.00	155
10	10	11.00	5.00	220
12	8	9.00	5.50	210
12	10	11.00	5.50	240
12	12	12.00	5.50	315
16	16	13.00	6.50	520

*Not included in AWWA C110.

*WYES / LATERALS				
Sizes				Domestic
Run	Branch	H	J	Tee
3	3	10.00	3.00	49
4	3	12.00	3.00	68
4	4	12.00	3.00	76
6	4	14.50	3.50	106
6	6	14.50	3.50	131
8	4	17.50	4.50	153
8	6	17.50	4.50	188
8	8	17.50	4.50	201
10	4	20.50	5.00	232
10	6	20.50	5.00	288
10	8	20.50	5.00	333
10	10	20.50	5.00	300
12	4	24.50	5.50	355
12	6	24.50	5.50	370
12	8	24.50	5.50	395
12	10	24.50	5.50	420
12	12	24.50	5.50	460
14	6	27.00	6.00	500
14	8	27.00	6.00	525
14	10	27.00	6.00	555
14	12	27.00	6.00	600
14	14	27.00	6.00	640
16	6	30.00	6.50	655
16	8	30.00	6.50	680
16	10	30.00	6.50	715
16	12	30.00	6.50	755
16	14	30.00	6.50	800
16	16	30.00	6.50	850
18	8	32.00	7.00	820
18	10	32.00	7.00	855
18	12	32.00	7.00	1003
18	14	32.00	7.00	940
18	16	32.00	7.00	990
18	18	32.00	7.00	1035
20	10	35.00	8.00	1095
20	12	35.00	8.00	1130
20	14	35.00	8.00	1170
20	16	35.00	8.00	1220
20	20	35.00	8.00	1345
24	24	40.50	9.00	2020
36	36	60.00	19.50	5740

*Not included in AWWA C110.

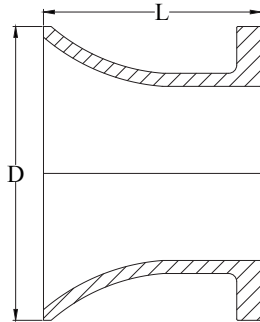

*FLANGE x FLARE PIECE			
Size	D	L	Weight
3	7.00	8.00	21
4	9.00	8.00	30
6	11.00	8.00	44
8	14.00	10.00	75
10	16.00	10.50	113
12	19.00	12.00	155
14	21.00	16.00	225
16	24.00	16.00	330
18	25.00	16.00	355
20	28.00	16.00	465
24	32.00	16.00	598
30	39.00	24.00	900
36	46.00	24.00	1200

*Not included in AWWA C110.

C110 DUCTILE IRON FULL BODY FITTINGS

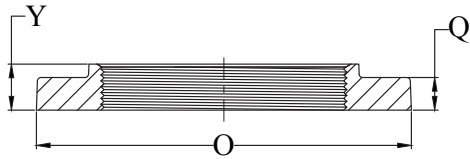

Flange for Steel Pipe
Reducing Flange for Steel Pipe

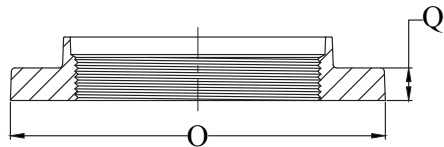

Flange for DI Pipe
Reducing Flange for DI Pipe

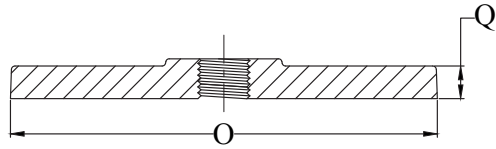

Under 12" Blind Flange
with Optional 2" Tap

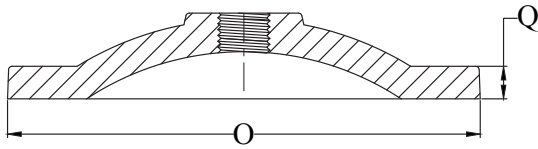

12" and Larger Blind Flange
with Optional 2" Tap

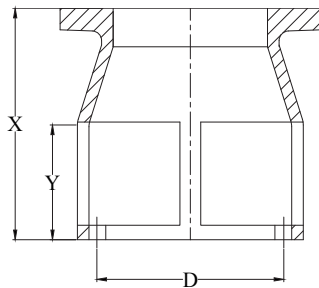

*FLANGE SLUDGE SHOE				
Size	D	X	Y	Domestic Weight
3	5.75	12.00	6.00	28
4	7.00	12.00	6.00	35
6	7.87	12.00	6.00	45
8	10.12	12.00	6.00	69
10	12.25	12.00	6.00	88
12	15.25	12.00	6.00	120

*Not included in AWWA C110.

FLANGES										
Size	Sizes				Domestic Weight	Import Weight	Domestic Weight	Import Weight	Domestic Weight	Import Weight
	O	Q	Y	Z	Steel	Steel	DI	DI	Blind	Blind
2	6.00	0.62	1.00	4.75	4	-	-	-	-	-
2½	7.00	0.69	1.13	5.50	6	-	-	-	-	-
3	7.50	0.75	1.19	6.00	9	-	6	7	8	9
4	9.00	0.94	1.31	7.50	15	-	13	12	14	16
6	11.00	1.00	1.56	9.50	20	-	19	17	27	25
8	13.50	1.12	1.75	11.75	31	-	29	26	38	38
10	16.00	1.19	1.94	14.25	50	-	36	38	55	66
12	19.00	1.25	2.19	-	63	-	61	57	73	85
14	21.00	1.38	2.25	-	-	-	59	61	116	120
16	23.50	1.44	2.50	-	-	-	78	83	153	145
18	25.00	1.56	2.69	-	-	-	98	98	176	179
20	27.50	1.69	2.88	-	-	-	103	110	215	244
24	32.00	1.88	3.25	-	-	-	147	145	348	364
30	38.75	2.12	-	-	-	-	255	212	615	546
36	46.00	2.38	-	-	-	-	360	324	900	958
42	53.00	2.62	-	-	-	-	535	533	1300	1300
48	59.50	2.75	-	-	-	-	650	646	1620	1740

DI REDUCING FLANGE THREADED FOR STEEL PIPE		
Size	Tap x O.D.	Domestic weight
4x3	3x9	16
6x4	4x11	25
8x4	4x13.5	44
8x6	6x13.5	31
10x6	6x16	50
12x6	6x19	60
10x8	8x16	55
12x10	10x19	72

DI REDUCING FLANGE THREADED FOR DUCTILE IRON PIPE		
Size	Tap x O.D.	Weight
4x3	3x9	16
6x4	4x11	25
8x4	4x13.5	40
8x6	6x13.5	35
10x8	8x16	50
12x8	8x19	85

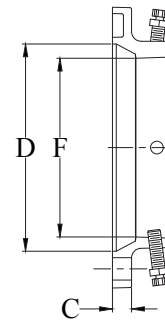
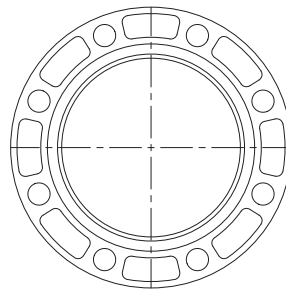

ADAPTER FLANGE									
Size	Rated Working Pressure	No. of Set Screws	Bolt Circle	Ductile Iron Pipe OD +.06 or -.06	D +.06 -.04	F +.07 -.03	C	Domestic Weight	Import Weight
3.00	250	4	6.00	3.96	4.94	4.06	0.94	7	6.5
4.00	250	4	7.50	4.80	6.02	4.90	1.00	8	8
6.00	250	8	9.50	6.90	8.12	7.00	1.06	12	12
8.00	250	8	11.75	9.05	10.27	9.15	1.12	18	18
10.00	250	12	14.25	11.10	12.34	11.20	1.19	28	28
12.00	150	12	17.00	13.20	14.44	13.30	1.25	40	34

All set screws are 5/8" 80lb. torque head.

Note: Recommended for class 53-class 56 wall thickness D.I. pipe.

C110 DUCTILE IRON FULL BODY FITTINGS

TAP LOCATIONS

Fittings can be supplied with tap sizes and located to ANSI B16.1 and MSS-SP-45. Specify fitting size, tap location by letter (refer to drawings below) and tap size by NPT dimension, on order.

NOTE: Boss is always required at location “Y” or “V” on straight and reducing sizes of 90° degree bends, and on tapered sides of reducers.

TAP LOCATIONS	
Fitting Size	Max Tap Without Boss
3	1/2
4-6	3/4
8	1 1/4
10-16	1 1/2
18-36	2

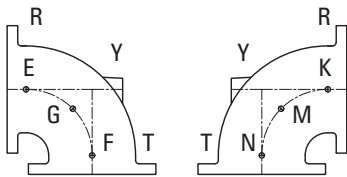

90° Bend, Straight Size

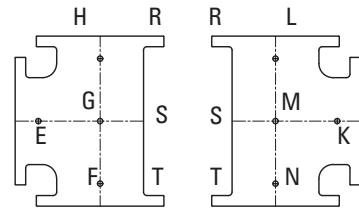

Tee, Straight Size

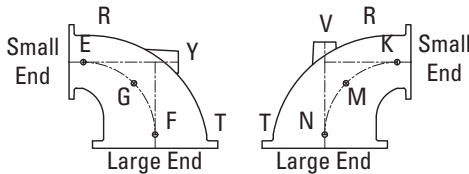

90° Bend, Reducing Size

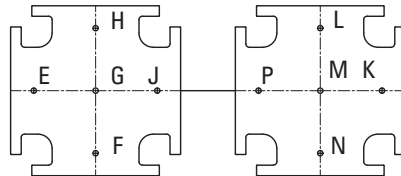

Cross, Straight Size

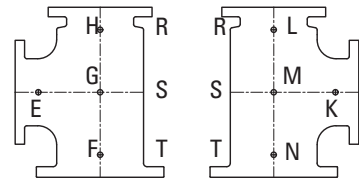

Tee, Reducing Size

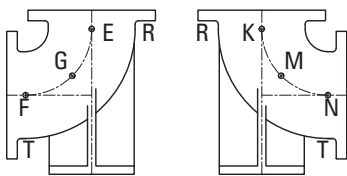

Base 90° Bend Elbow

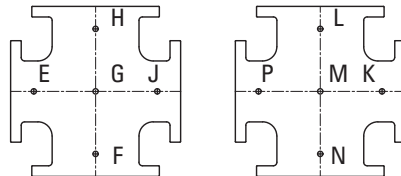

Cross, Reducing Size

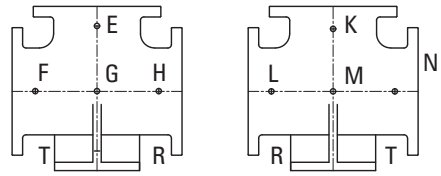

Base Tee

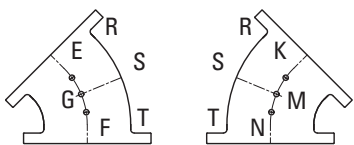

45° Bend

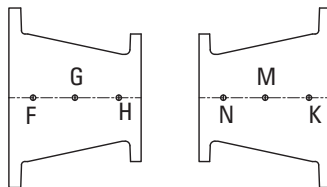

Concentric Reducer

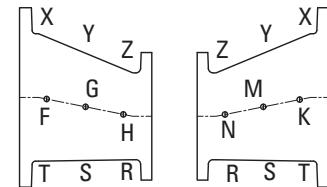

Eccentric Reducer

C110 DUCTILE IRON FULL BODY FITTINGS

SAMPLE SPECIFICATIONS

(Current ANSI/AWWA revisions apply)

Class 250 flanged fittings, 2” through 30”, shall be manufactured of ductile iron in accordance with all applicable terms and provisions of standard ANSI/AWWA C110/A21.10. Flange surfaces shall be faced and drilled in accordance with ANSI Class 250, B16.1. All ductile iron flanged fittings shall be rated for water pressure of 250 psi.

NOTE: Fittings are available prime coated, bare or epoxy coated. All coated fittings meet requirements of NSF-61, NSF-372 and Annex G. Interiors of fittings shall be lined and seal coated in accordance with ANSI/AWWA C104/A21.4. Cement mortar lining for ductile iron pipe and fittings for potable water unless otherwise specified. Installation of fittings shall be per AWWA C110.

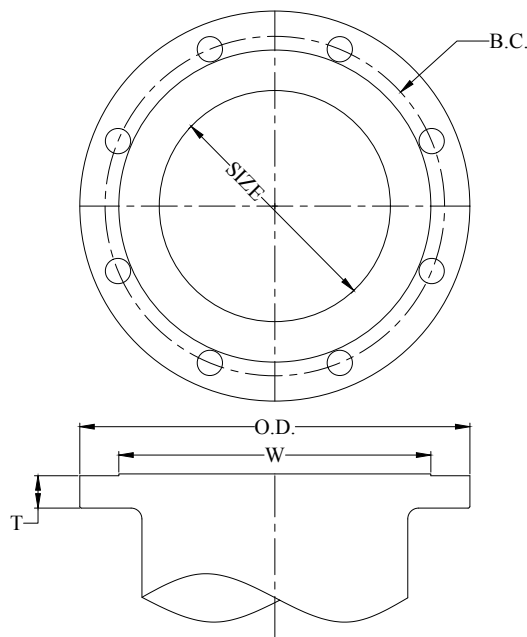

ANSI / AWWA C110 CLASS 250 FLANGE FITTINGS FLANGE DETAILS							
Nominal Pipe Size Inch	Flange O.D.	W (Raised Face)	Dia. of Bolt Circle	Flange Thickness T	Bolt Hole Diameter	Number of Bolts	Bolt Dia. and Lengths
2	6.50	4.19	5.00	0.88	0.750	8	5/8 x 3
3	8.25	5.69	6.62	1.12	0.875	8	3/4 x 3 1/2
4	10.00	6.94	7.88	1.25	0.875	8	3/4 x 4
6	12.50	9.69	10.62	1.44	0.875	12	3/4 x 4
8	15.00	11.94	13.00	1.62	1.000	12	7/8 x 4 1/2
10	17.50	14.06	15.25	1.88	1.125	16	1 x 5 1/2
12	20.50	16.44	17.75	2.00	1.250	16	1 1/8 x 5 1/2
14	23.00	18.94	20.25	2.12	1.250	20	1 1/8 x 6
16	25.50	21.06	22.50	2.25	1.375	20	1 1/4 x 6 1/2
18	28.00	23.31	24.75	2.38	1.375	24	1 1/4 x 6 1/2
20	30.50	25.56	27.00	2.50	1.375	24	1 1/4 x 7
24	36.00	30.31	32.00	2.75	1.625	24	1 1/2 x 7 1/2
30	43.00	37.19	39.25	3.00	2.000	28	1 3/4 x 8 1/2
36	50.00	43.69	46.00	3.38	2.250	32	2 x 11
42	57.00	50.44	52.75	3.69	2.250	36	2 x 11
48	65.00	58.44	60.75	4.00	2.250	40	2 x 11

*For LL information on sizes 36” and above contact Tyler Union.

C110 DUCTILE IRON FULL BODY FITTINGS

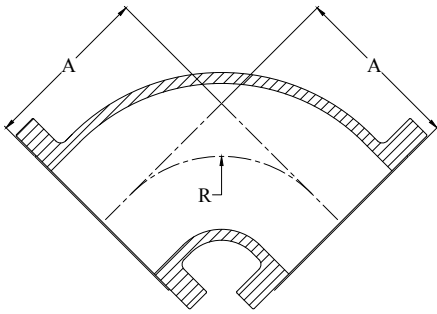

90° (1/4) BENDS		
Size	R	A
2	3.00	4.50
3	4.00	6.00
4	4.50	7.00
6	6.00	8.50
8	7.00	10.00
10	9.00	11.50
12	10.00	13.00
14	11.50	15.00
16	12.50	16.50
18	14.00	18.00
20	15.50	19.50
24	18.50	22.50
30	21.50	27.50

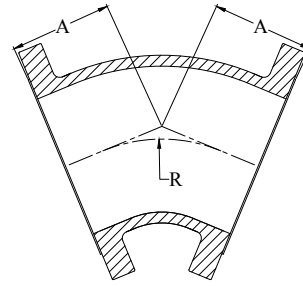

45° (1/8) BENDS		
Size	R	A
3	3.62	3.50
4	4.81	4.50
6	7.25	5.50
8	8.44	6.00
10	10.88	7.00
12	13.25	8.00
14	12.06	8.50
16	13.25	9.50
18	14.5	10.00
20	16.88	10.50
24	18.12	12.00
30	27.75	15.00

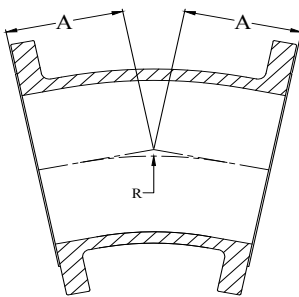

22 1/2° (1/16) BENDS		
Size	R	A
3	7.56	3.50
4	10.06	4.50
6	15.06	5.50
8	17.62	6.00
10	22.62	7.00
12	27.62	8.00

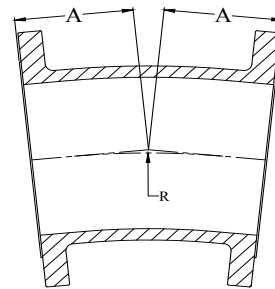

11 1/4° (1/32) BENDS		
Size	R	A
3	15.25	3.50
4	20.31	4.50
6	30.50	5.50
8	35.30	6.00
10	45.69	7.00
12	55.81	8.00

C110 DUCTILE IRON FULL BODY FITTINGS

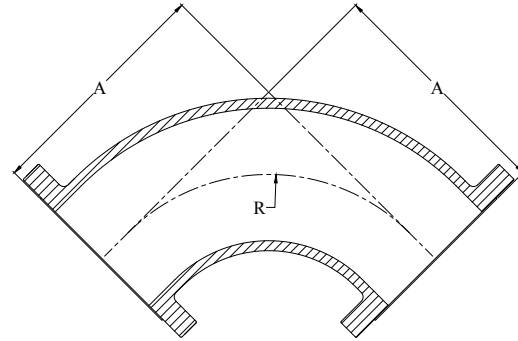
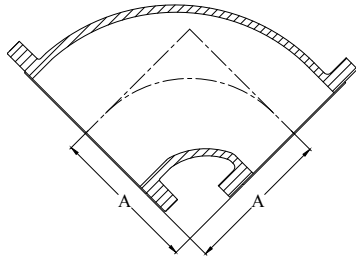

*90° REDUCING BEND (1/4)		
Size	A	Domestic Weight
4x3	6.50	35
6x4	8.00	—
8x4	9.00	—
8x6	9.00	—
10x6	11.00	—
10x8	10.00	—
12x6	12.00	—
12x8	12.00	—
12x10	12.00	—
14x3	14.00	—
14x8	14.00	—
16x10	16.00	—

*90° REDUCING BEND (1/4)			
Size	R	A	Domestic Weight
3	6.25	7.75	32
4	7.00	9.00	—
6	9.50	11.50	—
8	14.00	14.00	—
10	16.50	16.50	—
12	17.00	19.00	—
14	19.00	21.50	—
16	21.50	24.00	—
18	—	26.50	—
20	—	29.00	—
24	—	34.00	—

*Not included in AWWA C110.

*Not included in AWWA C110.

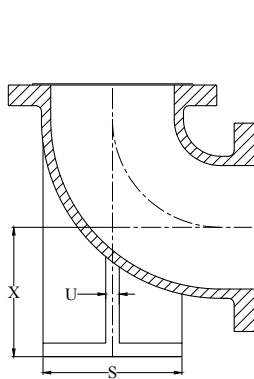

90° Base Bends

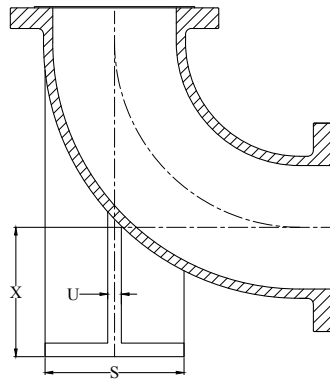

90° Long Radius Base Bends

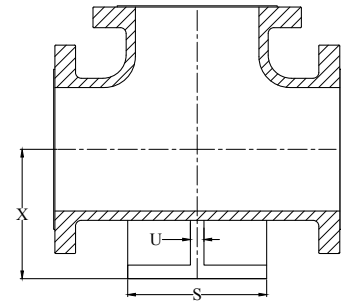

Base Tees

BASE BENDS / LONG RADIUS BENDS / BASE TEES				
Size	X	S	U	Support Pipe size
3	5.25	6.12	0.62	1.5
4	6.00	6.50	0.50	2
6	7.50	7.50	0.75	2.5
8	9.00	10.00	0.88	4
10	10.50	10.00	0.88	4
12	12.00	10.50	1.00	6
14	13.50	12.50	1.12	6
16	14.75	12.50	1.12	6
18	16.25	15.00	1.12	8
20	17.88	15.00	1.25	8
24	20.75	17.50	1.25	8
30	23.00	16.00	1.15	10
36	26.00	19.00	1.15	10

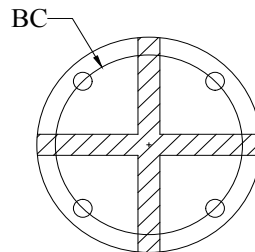

BASE DRILLING DETAILS			
Size	BC	Bolt Hole Diameter	No of Holes
3	4.50	7/8	4
4	5.00	3/4	4
6	5.88	7/8	4
8	7.88	7/8	4
10	7.88	7/8	4
12	10.62	7/8	4
14	10.62	7/8	4
16	10.62	7/8	4
18	13.00	7/8	4
20	13.00	7/8	4
24	15.25	1 1/8	4

Base Bends are made to order only and not returnable.
Bases are furnished faced and drilled.

C110 DUCTILE IRON FULL BODY FITTINGS

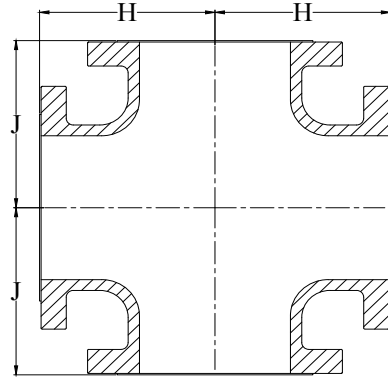
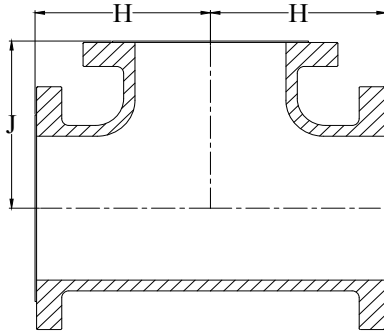

TEES & CROSSES						
Size					Domestic Weight	
Run	Run	Branch	H	J	Tee	Cross
2	2	2	5.00	5.00	—	—
3	3	2	6.00	6.00	—	—
3	3	3	6.00	6.00	60	—
4	4	3	7.00	7.00	—	—
4	4	4	7.00	7.00	87	118
*6	6	2	8.50	8.50	—	—
6	6	3	8.50	8.50	—	—
6	6	4	8.50	8.50	—	—
6	6	6	8.50	8.50	—	—
8	8	3	10.00	10.00	—	—
8	8	4	10.00	10.00	—	—
8	8	6	10.00	10.00	—	—
8	8	8	10.00	10.00	—	—
10	10	4	11.50	11.50	—	—
10	10	6	11.50	11.50	—	—
10	10	8	11.50	11.50	—	—
10	10	10	11.50	11.50	—	—
12	12	4	13.00	13.00	—	—
12	12	6	13.00	13.00	—	—
12	12	8	13.00	13.00	—	—
12	12	10	13.00	13.00	—	—
12	12	12	13.00	13.00	—	—
*14	14	4	15.00	15.00	—	—
14	14	6	15.00	15.00	—	—
14	14	8	15.00	15.00	—	—
14	14	10	15.00	15.00	—	—
14	14	12	15.00	15.00	—	—
14	14	14	15.00	15.00	—	—
*16	16	4	16.50	16.50	—	—
16	16	6	16.50	16.50	—	—
16	16	8	16.50	16.50	—	—
16	16	10	16.50	16.50	—	—
16	16	12	16.50	16.50	—	—
16	16	14	16.50	16.50	—	—
16	16	16	16.50	16.50	—	—

TEES & CROSSES						
Size					Domestic Weight	
Run	Run	Branch	H	J	Tee	Cross
18	18	6	14.00	17.00	—	—
18	18	8	14.00	17.00	—	—
18	18	10	14.00	17.00	—	—
18	18	12	14.00	17.00	—	—
18	18	14	18.00	18.00	—	—
18	18	16	18.00	18.00	—	—
18	18	18	18.00	18.00	—	—
20	20	6	15.50	18.50	—	—
20	20	8	15.50	18.50	—	—
20	20	10	15.50	18.50	—	—
20	20	12	15.50	18.50	—	—
20	20	14	15.50	18.50	—	—
20	20	16	19.50	19.50	—	—
20	20	18	19.50	19.50	—	—
20	20	20	19.50	19.50	—	—
24	24	6	17.00	21.50	—	—
24	24	8	17.00	21.50	—	—
24	24	10	17.00	21.50	—	—
24	24	12	17.00	21.50	—	—
24	24	14	17.00	21.50	—	—
24	24	16	17.00	21.50	—	—
24	24	18	22.50	22.50	—	—
24	24	20	22.50	22.50	—	—
24	24	24	22.50	22.50	—	—
*30	30	6	20.50	25.50	—	—
30	30	12	20.50	25.50	—	—
30	30	18	20.50	25.50	—	—
30	30	24	27.50	27.50	—	—
30	30	30	27.50	27.50	—	—

C110 DUCTILE IRON FULL BODY FITTINGS

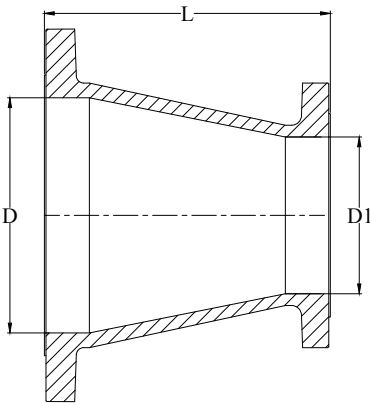

CONCENTRIC REDUCER		
Size		
D	D1	L
3.00	2.00	6.00
4.00	2.00	7.00
4.00	3.00	7.00
6.00	2.00	9.00
6.00	3.00	9.00
6.00	4.00	9.00
6.00	5.00	9.00
8.00	3.00	11.00
8.00	4.00	11.00
8.00	5.00	11.00
8.00	6.00	11.00
10.00	4.00	12.00
10.00	6.00	12.00
10.00	8.00	12.00
12.00	4.00	14.00
12.00	6.00	14.00
12.00	8.00	14.00
12.00	10.00	14.00
14.00	6.00	16.00
14.00	8.00	16.00
14.00	10.00	16.00
14.00	12.00	16.00
16.00	6.00	18.00
16.00	8.00	18.00
16.00	10.00	18.00
16.00	12.00	18.00
16.00	14.00	18.00
18.00	8.00	19.00
18.00	10.00	19.00
18.00	12.00	19.00
18.00	14.00	19.00
18.00	16.00	19.00
20.00	10.00	20.00
20.00	12.00	20.00
20.00	14.00	20.00
20.00	16.00	20.00
20.00	18.00	20.00
24.00	12.00	24.00
24.00	14.00	24.00
24.00	16.00	24.00
24.00	18.00	24.00
24.00	20.00	24.00
30.00	16.00	30.00
30.00	18.00	30.00
30.00	20.00	30.00
30.00	24.00	30.00

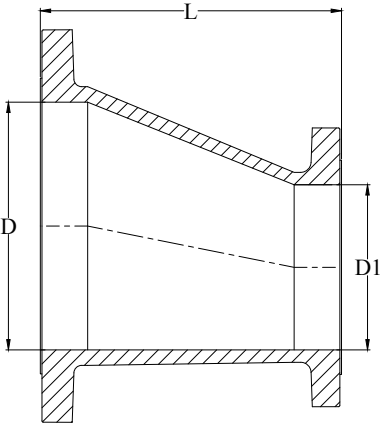

*ECCENTRIC REDUCER		
Size		
D	D1	L
4.00	3.00	7.00
6.00	3.00	9.00
6.00	4.00	9.00
8.00	4.00	11.00
8.00	6.00	11.00
10.00	4.00	12.00
10.00	6.00	12.00
10.00	8.00	12.00
12.00	4.00	14.00
12.00	6.00	14.00
12.00	8.00	14.00
12.00	10.00	14.00
14.00	6.00	16.00
14.00	8.00	16.00
14.00	10.00	16.00
14.00	12.00	16.00
16.00	6.00	18.00
16.00	8.00	18.00
16.00	10.00	18.00
16.00	12.00	18.00
16.00	14.00	18.00
18.00	8.00	19.00
18.00	10.00	19.00
18.00	12.00	19.00
18.00	14.00	19.00
18.00	16.00	19.00
20.00	10.00	20.00
20.00	12.00	20.00
20.00	14.00	20.00
20.00	16.00	20.00
20.00	18.00	20.00
24.00	12.00	24.00
24.00	14.00	24.00
24.00	16.00	24.00
24.00	18.00	24.00
24.00	20.00	24.00
30.00	16.00	30.00
30.00	18.00	30.00
30.00	20.00	30.00
30.00	24.00	30.00

*Not included in AWWA C110.

C110 DUCTILE IRON FULL BODY FITTINGS

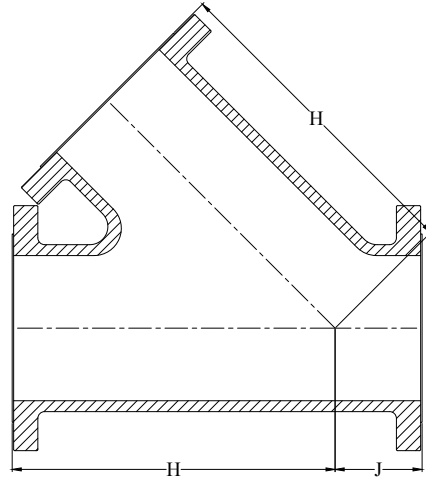
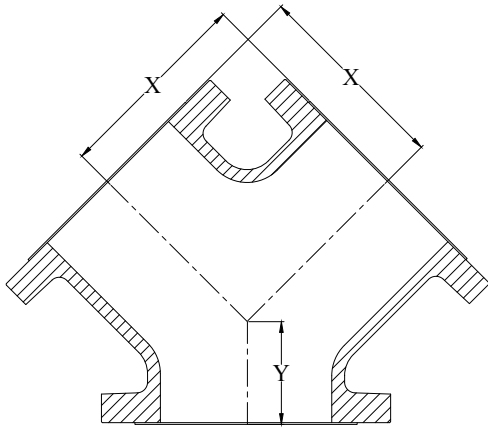

*TRUE WYES			
Size			
Stem	Branch	x	y
4	4	6.50	3.00
6	4	8.00	3.50
6	6	8.00	3.50
8	6	9.00	4.50
8	8	9.00	4.50
10	6	8.00	5.00
10	8	9.00	5.00
10	10	11.00	5.00
12	8	9.00	5.50
12	10	11.00	5.50
12	12	12.00	5.50
16	16	13.00	6.50

*Not included in AWWA C110.

*WYES / LATERALS			
Size			
Stem	Branch	H	J
3	3	11.00	3.00
4	3	13.50	3.00
4	4	13.50	3.00
6	4	17.50	4.00
6	6	17.50	4.00
8	4	20.50	5.00
8	6	20.50	5.00
8	8	20.50	5.00
10	4	24.00	5.50
10	6	24.00	5.50
10	8	24.00	5.50
10	10	24.00	5.50
12	4	27.50	6.00
12	6	27.50	6.00
12	8	27.50	6.00
12	10	27.50	6.00
12	12	27.50	6.00
14	6	31.00	6.50
14	8	31.00	6.50
14	10	31.00	6.50
14	12	31.00	6.50
14	14	31.00	6.50
16	6	34.50	7.50
16	8	34.50	7.50
16	10	34.50	7.50
16	12	34.50	7.50
16	14	34.50	7.50
16	16	34.50	7.50
18	8	37.50	8.00
18	10	37.50	8.00
18	12	37.50	8.00
18	14	37.50	8.00
18	16	37.50	8.00
18	18	37.50	8.00
20	20	40.50	8.50
24	24	47.50	10.00

*Not included in AWWA C110.

C110 DUCTILE IRON FULL BODY FITTINGS

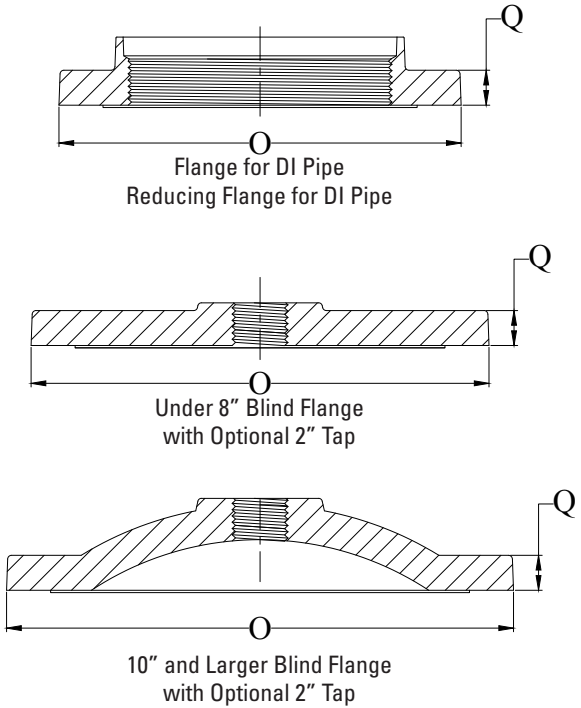

FLANGES		
Size	O	Q
2	6.00	0.62
3	7.50	0.75
4	9.00	0.94
6	11.00	1.00
8	13.50	1.12
10	16.00	1.19
12	19.00	1.25
14	21.00	1.38
16	23.50	1.44
18	25.00	1.56
20	27.50	1.69
24	32.00	1.88
30	38.80	2.12
36	46.00	2.38
42	53.00	2.62
48	59.50	2.75

CAST IRON SCREW TYPE VALVE BOXES

for 1 1/4" through 2" curbstops, enlarged base
accommodates 2" curbstops, 2 1/2" shaft — screw type

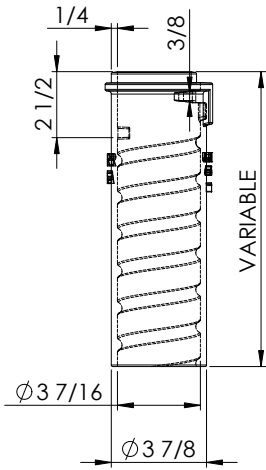

6500 SERIES, SCREW TYPE ASSEMBLIES WITH WATER LID					
BOX (components)	**D-UPC 670610	Weight	Extensions In inches	** (ND) UPC 670610	Weight
89-A (12T & 12B)	146681	20	15-21	111863	20
90-B (12T & 15B)	146742	21	18-24	111870	21
90-C (15T & 15B)	146803	22	21-27	111887	24
91-C (15T & 21B)	146865	24	24-33	111894	26
92-C (15T & 27B)	146926	26	30-39	111900	28
92-D (18T & 27B)	146988	28	30-42	111917	29
93-D (18T & 33B)	147046	32	36-48	111924	33
93-E (24T & 33B)	147114	37	36-54	111931	39
94-E (24T & 39B)	147183	41	42-60	111948	44
95-E (30T & 39B)	147251	44	41-64	111955	49
100-E (24T & 21B & #154 Ext)	147312	50	54-72	111832	55
100-F (30T & 21B & #154 Ext)	147381	53	54-78	111849	59
101-F (30T & 27B & #154 Ext)	147459	55	60-84	111856	61

** D=Domestic ND=Import

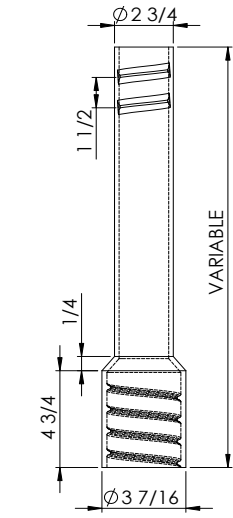
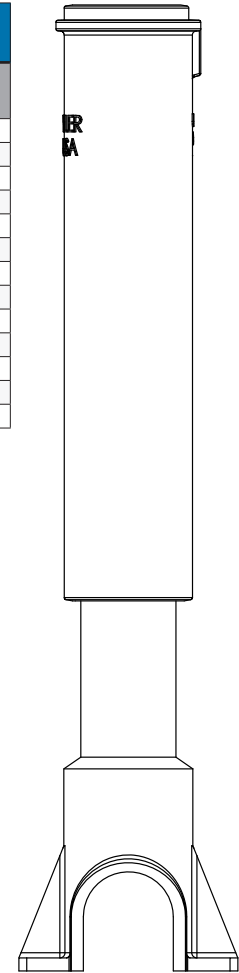

TOP SECTION WITH WATER LID				
Item	**D-UPC 670610	Weight	** (ND) UPC 670610	Weight
12T	147510	11	112006	12
15T	147589	12	112013	15
18T	147640	15	112020	16
24T	147701	19	112037	22
30T	147763	30	112044	27

** D=Domestic ND=Import

BOTTOM ONLY				
Item	**D-UPC 670610	Weight	** (ND) UPC 670610	Weight
12B	144670	9	136941	8
15B	144687	10	111788	9
21B	144694	13	111795	11
27B	144700	15	111801	13
33B	144717	19	111818	17
39B	144724	21	111825	22

** D=Domestic ND=Import

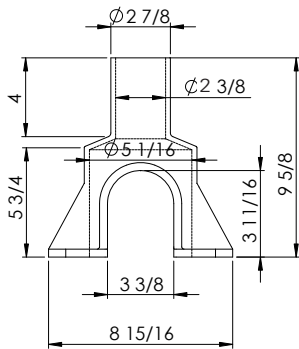
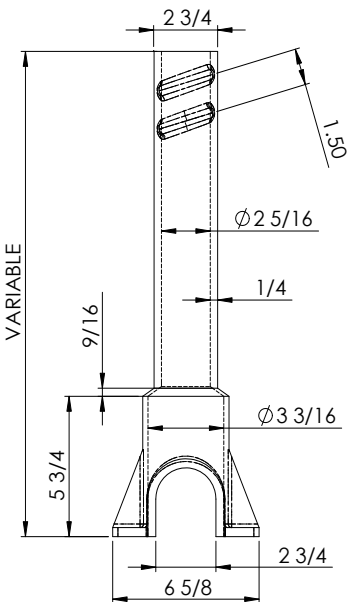

6500 PARTS					
Item	**D-UPC 670610	Weight	** (ND) UPC 670610	Weight	Height Increase
151 Extension	144762	8	111962	9	9
152 Extension	144779	11	111979	14	16
153 Extension	144786	16	111786	21	28
154 Extension	144793	17	111993	21	30
Enlarged Base	144809	9	136934	11	6
2 1/2" Water Lid	144830	1	-	-	-
Brass Screw	144816	-	-	-	-
Wrench	144908	0.5	-	-	-
2 1/2" Repair Lid Outside cover	385518	2	-	-	-

** D=Domestic ND=Import

CAST IRON TWO-PIECE VALVE BOXES for 4" through 12" valves, 5 1/4 shaft, screw type

Tyler Union Valve boxes are available either assembled or as individual tops and bottoms.

NOTE: Domestic valve boxes available in Heavy Duty only. Non-Domestic available in Standard or Heavy Duty.

6850 ASSEMBLED BOXES (LESS LID)						
Box (Components)	Extension Height	** (D-HD) UPC 670610	** (ND-HD) UPC 670610	Weight	** (ND-Std) UPC 670610	Weight
461-S (10T + 15B)	19-22	145776	502098	50	112280	35
462-S (10T + 24B)	27-32	145783	502104	58	112297	43
562-S (16T + 24B)	27-37	145790	502111	71	112303	50
563-S (16T + 30B)	33-43	145752	-	78	112310	60
564-S (16T + 36B)	39-50	145806	502128	85	112327	66
662-S (26T + 30B)	36-52	145769	-	93	112341	76
664-S (26T + 36B)	39-60	145813	-	100	112358	84
665-S (26T + 24B)	39-63	375296	-	87	-	-
666-S (26T+24B+60 Ext)	53-71	145820	502135	128	112365	95
668-S (26T+36B+60 Ext)	64-82	145837	-	136	112372	111

** D = Domestic ND = Import HD = Heavy Duty Weight Std. = Standard Weight

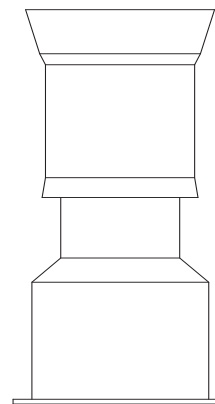

6850 Assembly
(Less Lid)

6850 INDIVIDUAL TOPS (LESS LID)							
Box	Top length	** (D-HD) UPC 670610	Weight	** (ND-HD) UPC 670610	Weight	** (ND-Std) UPC 670610	Weight
461-S	(10T)	144939	22	502142	23	112402	15
462-S	(10T)	144939	22	502142	23	112402	15
562-S	(16T)	144946	37	502159	36	112419	22
563-S	(16T)	144946	37	502159	36	112419	22
564-S	(16T)	144946	37	502159	36	112419	22
662-S	(26T)	144953	51	502166	51	112426	38
664-S	(26T)	144953	51	502166	51	112426	38
666-S	(26T)	144953	51	502166	51	112426	38
668-S	(26T)	144953	51	502166	51	112426	38

** D = Domestic ND = Import HD = Heavy Duty Weight Std. = Standard Weight

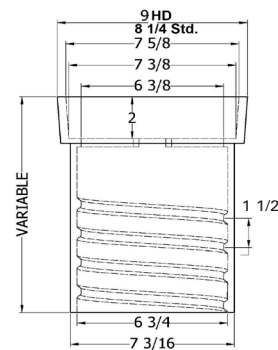

Top

6850 INDIVIDUAL BOTTOMS							
Box	Bottom Length	** (D-HD) UPC 670610	Weight	** (ND-HD) UPC 670610	Weight	** (ND-Std) UPC 670610	Weight
461-S	(15B)	145004	29	502173	27	112242	20
462-S	(24B)	145011	35	502180	35	112259	28
562-S	(24B)	145011	35	502180	35	112259	28
563-S	(30B)	144991	41	502197	42	112266	38
564-S	(36B)	145028	52	502203	49	112273	44
662-S	(30B)	144991	41	502197	42	112266	38
664-S	(36B)	145028	52	502203	49	112273	44
666-S	(24B)	145011	35	502180	35	112259	28
668-S	(36B)	145028	52	502203	49	112273	44
-	(48B)	-	-	-	-	452737	62
-	(60B)	-	-	-	-	452744	85

** D = Domestic ND = Import HD = Heavy Duty Weight Std. = Standard Weight

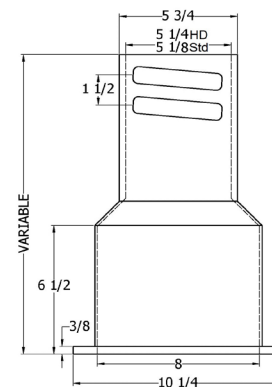

Bottom

See page 50 for extensions.

CAST IRON TWO-PIECE VALVE BOXES for 4" through 12" valves, 5 1/4 shaft, slip type

Tyler Union Valve boxes are available either assembled or as individual tops and bottoms.

NOTE: Domestic valve boxes available in Heavy Duty only. Non-Domestic available in Standard or Heavy Duty.

6855 ASSEMBLED BOXES (LESS LID)						
Box (Components)	Extension Height	** (D-HD) UPC 670610	** (ND-HD) UPC 670610	Weight	** (ND-Std.) UPC 670610	Weight
461-A (10T + 15B)	19-22	145844	502234	55	112099	34
462-A (10T + 24B)	27-32	145831	-	65	112105	48
562-A (16T + 24B)	27-37	145868	502241	72	112112	55
563-A (16T + 30B)	33-43	145714	-	81	112129	67
564-A (16T + 36B)	39-50	145875	502258	83	112136	72
662-A (26T + 30B)	36-52	145721	-	97	112143	83
664-A (26T + 36B)	39-60	145882	502265	99	112150	88
666-A (26T+24B+60 Ext)	53-71	145899	-	124	112167	108
668-A (26T+36B+60 Ext)	64-82	145905	-	135	112181	124

** D = Domestic ND = Import HD = Heavy Duty Weight Std. = Standard Weight

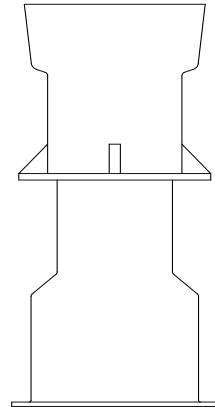

6855 Assembly
(Less Lid)

6855 INDIVIDUAL TOPS (LESS LID)							
Box	Top Length	** (D-HD) UPC 670610	Weight	** (ND-HD) UPC 670610	Weight	** (ND-Std.) UPC 670610	Weight
461-A	(10T)	144960	28	502272	29	112211	16
462-A	(10T)	144960	28	502272	29	112211	16
562-A	(16T)	144977	34	502289	36	112228	25
563-A	(16T)	144977	34	502289	36	112228	25
564-A	(16T)	144977	34	502289	36	112228	25
662-A	(26T)	144984	44	502296	52	112235	41
664-A	(26T)	144984	44	502296	52	112235	41
666-A	(26T)	144984	44	502296	52	112235	41
668-A	(26T)	144984	44	502296	52	112235	41

** D = Domestic ND = Import HD = Heavy Duty Weight Std. = Standard Weight

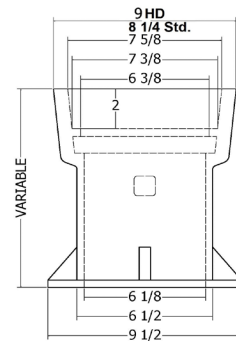

Top

6855 INDIVIDUAL BOTTOMS							
Box	Bottom Length	** (D-HD) UPC 670610	Weight	** (ND-HD) UPC 670610	Weight	** (ND-Std.) UPC 670610	Weight
461-A	(15B)	145073	27	502302	26	112051	18
462-A	(24B)	145080	36	502319	36	112068	30
562-A	(24B)	145080	36	502319	36	112068	30
563-A	(30B)	145127	47	502333	45	112075	42
564-A	(36B)	145097	51	502340	47	112082	47
662-A	(30B)	145127	47	502333	45	112075	42
664-A	(36B)	145097	51	502340	47	112082	47
666-A	(24B)	*145080	36	*502319	36	*112068	30
668-A	(36B)	*145097	51	*502240	47	*112082	47
-	(60B)	-	-	-	-	458302	75

** D=Domestic ND=Import HD=Heavy Duty Weight Std.=Standard Weight

*Note: When installing with an extension, a 6850 screw type bottom is required.

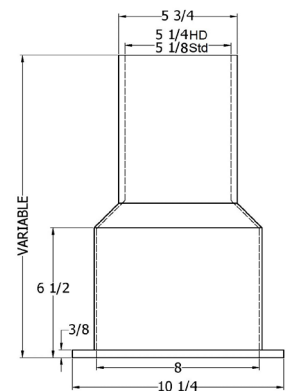

Bottom

See page 50 for extensions.

CAST IRON THREE-PIECE VALVE BOXES for 3" through 20" valves, 5 1/4 shaft, screw type (Base required, order separately)

Tyler Union Valve boxes are available either assembled or as individual tops and bottoms.

NOTE: Domestic valve boxes available in Heavy Duty only. Non-Domestic available in Standard or Heavy Duty.

6860 ASSEMBLED BOXES (LESS LID)						
Box (Components)	Extension Height	** (D-HD) UPC 670610	** (ND-HD) UPC 670610	Weight	** (ND-Std.) UPC 670610	Weight
AA (10T + 12B)	27-37	145912	-	42	136668	29
A (16T + 18B)	33-42	145929	-	65	136651	38
B (16T + 24B)	39-49	145936	-	69	136675	51
C (16T + 30B)	45-54	145943	-	73	136682	55
CC (16T + 36B)	51-60	145950	-	75	136699	59
D (26T + 30B)	45-66	145967	502357	88	136811	71
DD (26T + 36B)	51-72	145974	502364	90	136828	75
E (16T+24B+60 Ext)	63-72	145981	-	105	136835	80
F (26T+24B+60 Ext)	63-84	145998	-	120	136842	96
G (26T+36B+60 Ext)	74-94	146001	502371	126	136859	104

** D = Domestic ND = Import HD = Heavy Duty Weight Std. = Standard Weight

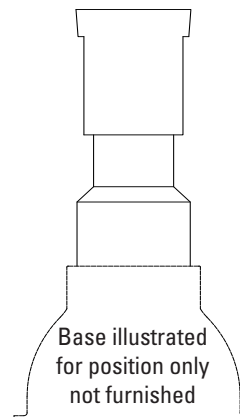

6860 Assembly
(Less Lid)

6860 INDIVIDUAL TOPS (LESS LID)							
Box	TOP Length	** (D-HD) UPC 670610	Weight	** (ND-HD) UPC 670610	Weight	** (ND-Std.) UPC 670610	Weight
AA	(10T)	144939	22	502142	23	112402	15
A	(10T)	144939	22	502142	23	112402	15
B	(16T)	144946	37	502159	36	112419	22
C	(16T)	144946	37	502159	36	112419	22
CC	(16T)	144946	37	502159	36	112419	22
D	(26T)	144953	51	502166	49	112426	38
DD	(26T)	144953	51	502166	49	112426	38
E	(16T)	144946	37	502159	36	112419	22
F	(26T)	144953	51	502166	49	112426	38
G	(26T)	144953	51	502166	49	112426	38

** D = Domestic ND = Import HD = Heavy Duty Weight Std. = Standard Weight

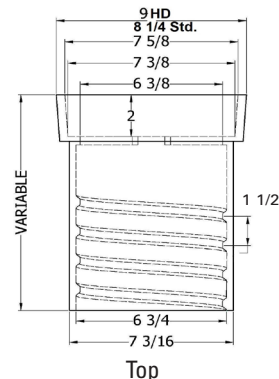

Top

6860 INDIVIDUAL BOTTOMS							
Box	Bottom Length	** (D-HD) UPC 670610	Weight	** (ND-HD) UPC 670610	Weight	** (ND-Std.) UPC 670610	Weight
AA	(12B)	145134	24	-	-	250524	14
A	(18B)	145141	27	505594	29	250517	23
B	(24B)	145158	33	502388	33	136958	29
C	(30B)	145165	40	502395	37	136613	33
CC	(36B)	145172	45	502401	42	136620	43
D	(30B)	145165	40	502395	37	136613	33
DD	(36B)	145172	45	502401	42	136620	43
E	(24B)	145158	33	502388	33	136958	29
F	(24B)	145158	33	502388	33	136958	29
G	(36B)	145172	45	502401	42	136620	43
-	(48B)	-	-	-	-	452713	55
-	(60B)	-	-	-	-	452720	91

** D=Domestic ND=Import HD=Heavy Duty Weight Std.=Standard Weight

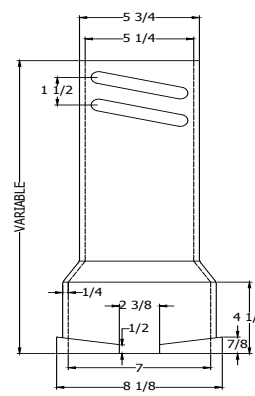

Bottom

See page 50 for extensions.

CAST IRON THREE-PIECE VALVE BOXES
for 3" through 20" valves, 5/4 shaft, screw type
(Base required, order separately)

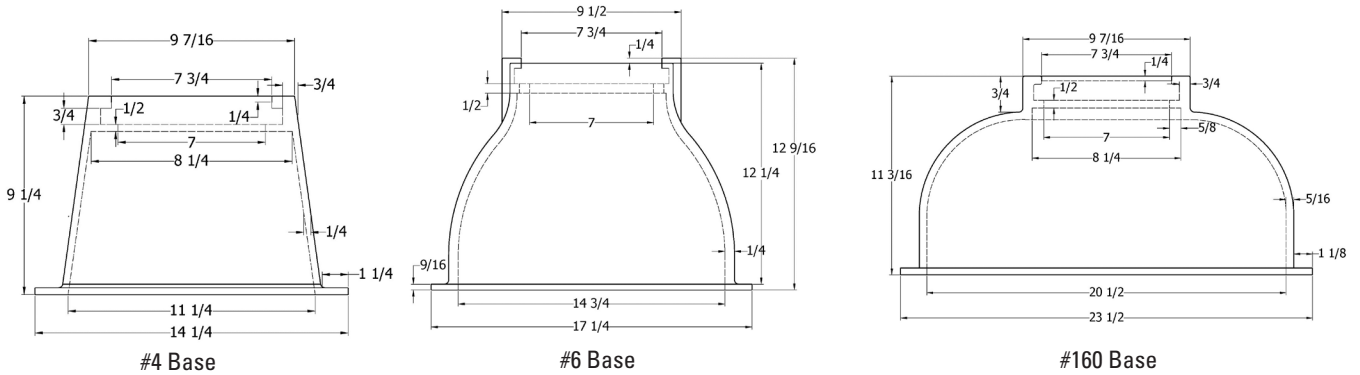

6860 BASES						
Item Description	** (D-HD) UPC 670610	Weight	** (ND)UPC 670610	Weight	** (ND-Std) UPC 670610	Weight
#4, 11 1/4" Wide	145653	42	-	34	381532	22
#6, 14 3/4" Wide	145660	42	502432	45	381525	36
#160, 20 1/2" Wide	145684	71	502425	88	256861	55

** D = Domestic ND = Import HD = Heavy Duty Weight Std. = Standard Weight

6850/60 EXTENSIONS							
Item/Description	Height Increase	** (D-HD) UPC 670610	Weight	** (ND-HD) UPC 670610	Weight	** (ND-Std.) UPC 670610	Weight
#58 Screw-Type	14	145141	27	505594	29	250517	23
#59 Screw-Type	18	145158	32	502388	-	136958	29
#60 Screw-Type	24	145059	39	502210	36	112389	29

** D = Domestic ND = Import HD = Heavy Duty Weight Std. = Standard Weight

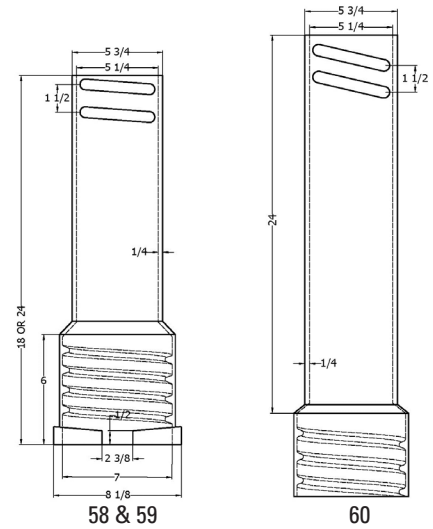

6855 EXTENSIONS					
Item/Description	Height Increase	** (D-HD) UPC 670610	Weight	** (ND-Std.) UPC 670610	Weight
#58-A Slip-Type	6-14	145233	30	136637	26
#59-A Slip-Type	6-18	145240	35	136644	28
#60-A Slip-Type	6-24	145066	41	112198	39

*NOTE: When installing these extensions, a 6850 screw type bottom is required.

** D = Domestic ND = Import HD = Heavy Duty Weight Std. = Standard Weight

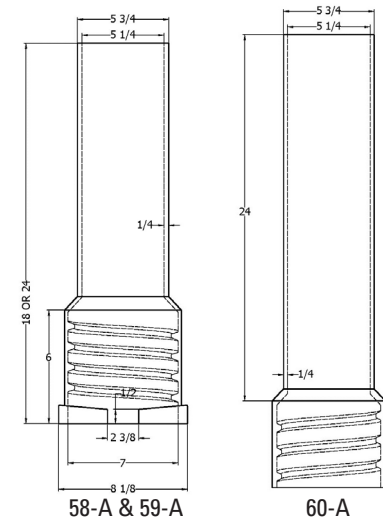

DROP AND LOCK LIDS

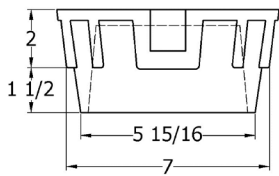
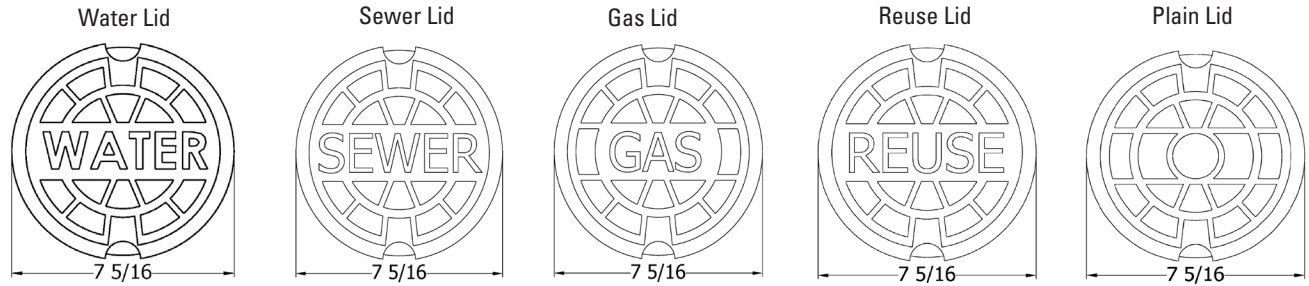

*5 1/4 DROP LID					
Item Description	** (D-HD) UPC 670610	Weight	** (ND) UPC 670610	Weight	Marking
5 1/4 Drop Lid	145325	12	136910	9	WATER
5 1/4 Drop Lid	145349	12	136903	9	SEWER
5 1/4 Drop Lid	145332	12	136873	9	GAS
5 1/4 Drop Lid	458975	12	-	-	REUSE
5 1/4 Drop Lid	145356	12	136897	9	PLAIN

** D = Domestic ND = Import HD = Heavy Duty Weight Std. = Standard Weight
 *Lids marked WATER will be shipped unless otherwise specified.

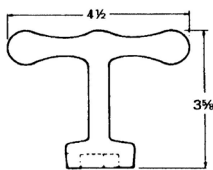
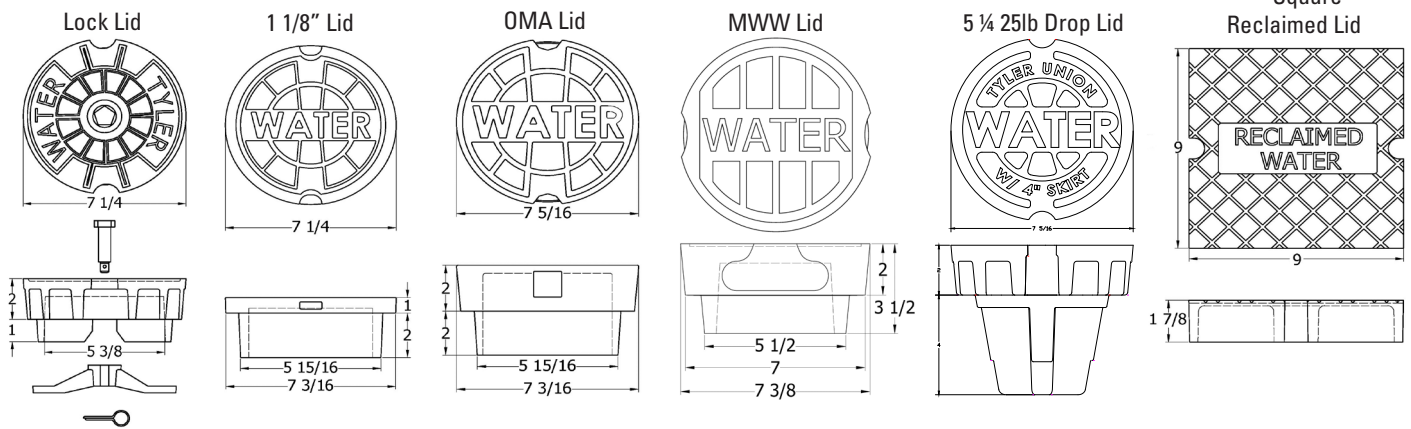

Wrench
 Fits Standard Waterworks
 Pentagon Head 27/32" Brass
 Screws

WRENCH		
Description	UPC 670610	Weight
Wrench	144908	0.5

SPECIALTY LIDS					
Item Description	** (D-HD) UPC 670610	Weight	** (ND) UPC 670610	Weight	Marking
5 1/4 Lock Lid	145462	12	136866	11	WATER
*1 1/8 Lid	145509	10	112532	9	WATER
5 1/4 OMA Drop Lid	145370	12	136927	12	WATER
5 1/4 MWW Drop Lid	145370	12	136880	12	WATER
5 1/4 25lb Drop Lid	145451	25	-	-	WATER
***Square Drop Lid	458982	14	-	-	RECLAIMED WATER

*Note: Use with 1 1/8 riser only.
 ** D = Domestic ND = Non-Domestic HD = Heavy Duty Weight Std. = Standard Weight
 ***Note: Use with 9T Top #144622.

CAST IRON — FIXED AND ADJUSTABLE RISERS PLUS SPECIALTY VALVE BOX TOPS

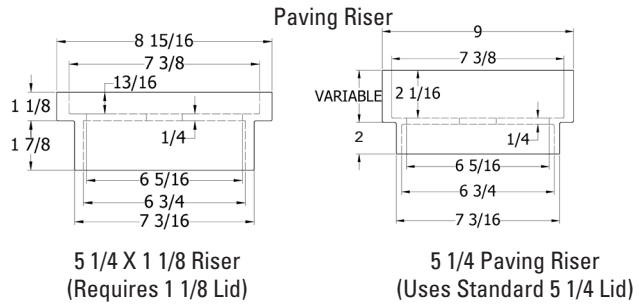
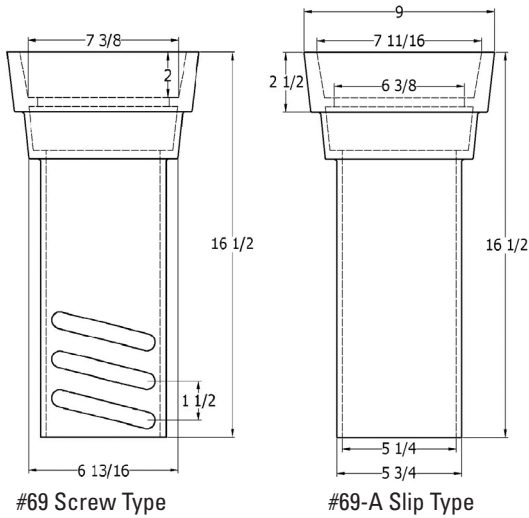

RISERS					
Item / Description	Height Increase	**D-HD) UPC 670610	Weight	**ND-UPC 670610	Weight
5 1/4 x 1 Slip-In	1	533641	8	—	—
*5 1/4 x 1 1/8 Slip-In	1 1/8	145554	9	112549	8
5 1/4 x 1 1/2 Slip-In	1 1/2	533672	11	—	—
5 1/4 x 2 Slip-In	2	533689	13	—	—
5 1/4 x 2 1/4 Slip-In*	2 1/4	145547	15	112556	12
5 1/4 x 3 Slip-In	3	533696	20	—	—
5 1/4 x 4 Slip-In	4	533702	28	—	—

* Note: Works with 1 1/8 Lid #145509.
 ** D = Domestic ND = Import

ADJUSTABLE RISER					
Item/Description	Height Increase	*(D-HD)UPC 670610	Weight	*(ND-HD) UPC 670610	Weight
#69 Adjustable Riser	2 1/2"-9"	148197	32	112396	26
#69-A Adjustable Riser	2 1/2"-12"	148241	31	112204	29

** D = Domestic ND = Import HD = Heavy Duty Weight

G05 Valve Box & Lid

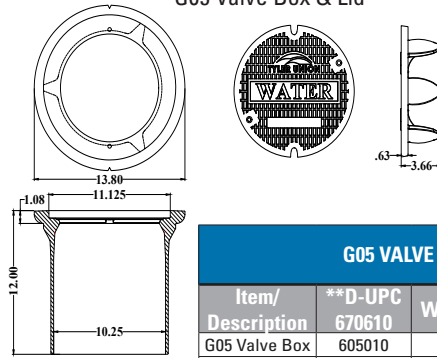

G05 VALVE BOX & LID				
Item/Description	**D-UPC 670610	Weight	**ND-UPC 670610	Weight
G05 Valve Box	605010	42	605005	42
G05 Lid	502551	16	605000	16
G05 Box & Lid	506011	58	605007	58

Specialty Tops

7126 Top (Uses Standard 5 1/4 Lids)

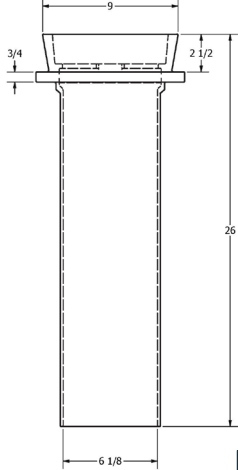

Square Top

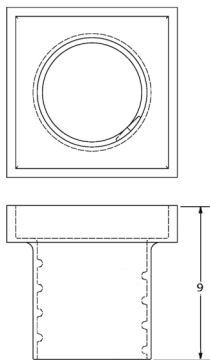

910 18T Top

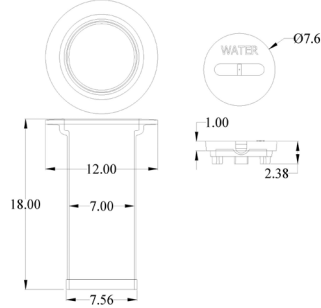

940 18T Top

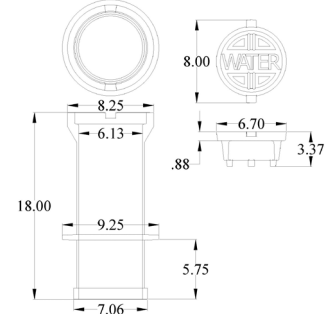

SPECIALTY TOPS				
Item/Description	**D-UPC 670610	Weight	**ND-UPC 670610	Weight
7126 26T Top	376774	42	481140	36
*Square 9T Top	144622	36	—	—
910 18T Top	—	—	502883	37
910 18T Top w/Lid	—	—	457305	49
940 18T Top	—	—	502890	35
940 18T Top w/Lid	—	—	457299	45
Monument Box w/Lid	—	—	506904	67

** D = Domestic ND = Import * Works with Square Lid #458982.

Monument Box with Lid

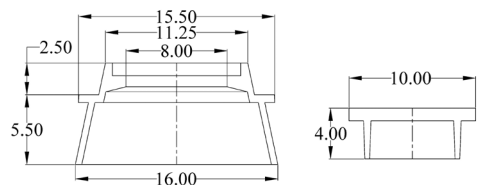

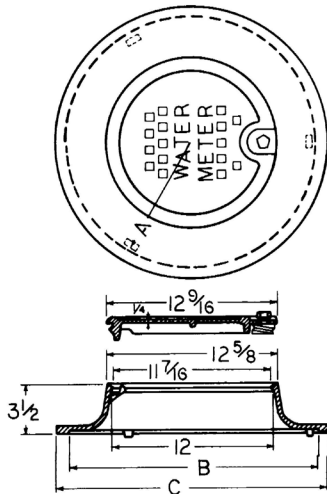

6150 & 6150 TR METER COVERS CAST IRON			
Item/Description	A	B	C
18" 6150 Series	8 3/4"	18	20
20" 6150 Series	9 3/4"	20	22

6150 METER COVERS CAST IRON		
Item/Description	UPC 670610	Weight
6150-18 Ring & Lid B/L*	148449	38
6150-18 Ring & Lid B/S*	148456	38
6150-18 Ring Only	148647	27
6150 -18/20 Lid with Lock B/L*	148494	11
6150 -L-18/20 Lid less lock	148593	14
6150-18 / 20 Lid with Lock B/S*	148500	11
6150-20 Ring & Lid B/L*	148463	37
6150-20 Ring & Lid B/S*	148470	37
6150-20 Ring Only	148630	27

*B/L = large head bolts (1 - 1/32"); *B/S = small head bolts (27/32" Standard)

NOTE: The B/L & B/S pentagon head screws use the same worm or locking gear.

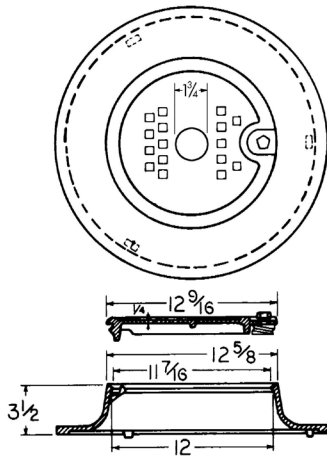

6150TR METER COVER CAST IRON		
Item/Description	UPC 670610	Weight
6150-18 TR Ring & Lid B/L*	148531	40
6150-18 TR Ring & Lid B/S*	148524	40
6150-18/20 TR Lid With Lock B/L*	148579	14
6150-18/20 TR Lid Less Lock	148586	14
6150-18/20 TR Lid With Lock B/S*	148562	14
6150-20 Ring & Lid B/L*	148555	40
6150-20 Ring & Lid B/S*	148548	40
6150-20 Ring & Lid B/S*	148470	40

*B/L = large head bolts (1 - 1/32"); *B/S = small head bolts (27/32" Standard)

NOTE: The B/L & B/S pentagon head screws use the same worm or locking gear.

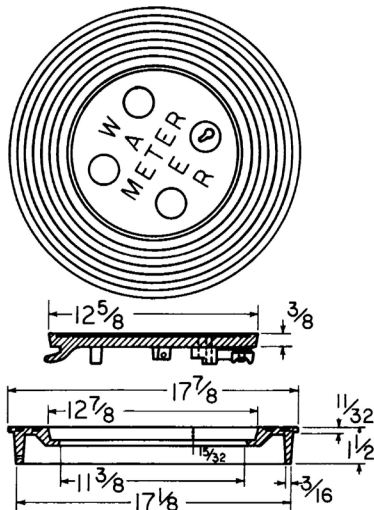

6200 METER COVER CAST IRON		
Item/Description	UPC 670610	Weight
6200 Ring & Lid Less Lock	148708	28
6200-R Ring Only	148760	18
6200-L Lid Less Lock	148739	13
6200-L Lid With Lock	148722	11

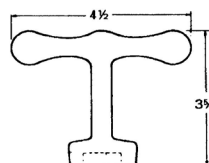

WRENCH		
Description	UPC 670610	Weight
Wrench	144908	0.5

MJ TUFGRIP® TLD

SERIES 1000

FOR DUCTILE IRON PIPE

A Proven Third-Generation Mechanical Joint Restraint



Tyler Union’s TUFGrip® restraint represents the culmination of 20 years of engineering and testing. As a third-generation restraint, TUFGrip is the best available technology in the waterworks market for use in restraining PVC, ductile and HDPE pipe.

FEATURES & ADVANTAGES

- Torque limiting nut on gripping wedge assembly twists off within a designed torque range, eliminating the need for specialized tools.
- Gripping wedge assembly pivots provide stronger engagement of pipe wall at lower torque requirement (45–60 ft-lb).
- Proven restraint technology utilizing fewer gripping wedges in frequently applied diameters, reducing trench time and project cost.
- Restraint’s heavy-duty construction and design eliminates the need for costly thrust blocks and tie rods.
- Suitable for potable and wastewater applications.

SPECIFICATIONS

- Designed and proven to restrain plain end ductile iron pipe conforming to ANSI/AWWA C151/A21.51 in diameters 3”–48” with a maximum surface hardness value of 250 Brinell at the engagement point of the wedges. (ISO 2531 for Ductile Iron Pipe specifies a maximum hardness value of 230 Brinell).
- Proven for use on heavy wall **Schedule 40 or greater steel pipe in sizes 3”–12” and on all sizes 3”–16” when pipe O.D. and wall thickness conforms to C151 **Note: IPS diameter steel pipe requires the use of an MJ Transition gasket .
- Restraint design conforms with applicable requirements of ANSI/AWWA C111, ANSI/AWWA C153 and ANSI/AWWA C110.
- Restraint engineered for securing plain end pipe to mechanical joint fittings conforming to ANSI/AWWA C110, C111 and C153.
- Restraints rated for working water pressure of 350 psi and transitory surges of 100 psi for 3”–16” and 250 psi for 18”–48”.
- Cast of ASTM A536 compliant 65-45-12 ductile iron complete with a cast on date code and country of origin for traceability.
- Restraints and all components are designed and proven for a 2:1 safety factor based on the pipe pressure rating.
- Restraint deflection rating when installed on nominal diameter pipe: 3° max for 3”, 5° max for 4”–12”, 2° max for 14”–16” and 1.5° max for 18”–48”.
- Standard coating for domestic restraint is 4–6 mil of TUF-Bond™ (thermoset polyester for impact, corrosion and UV protection).
- Gripping wedges are heat treated to a minimum 420 Brinell hardness.
- Gripping wedge, wedge collar bolt and twist-off torque limiting nut shall be E-coated.
- FM approved for 4”–12” applications and UL listed and approved for 3”–36” applications.
- Not recommended for use on plain end fittings.
- Color coded black for pipe type (ductile/*cast iron/*steel) *Note: Refer to the following pages for cast iron and steel pipe applications.

ISO 9001-2015 Registered	Listed with Underwriters Laboratory	Factory Mutual Approved
--------------------------	-------------------------------------	-------------------------

Product Source/Type	Name of Project	Name of Contractor	Project Engineer	Spec. Section and/or Project No.



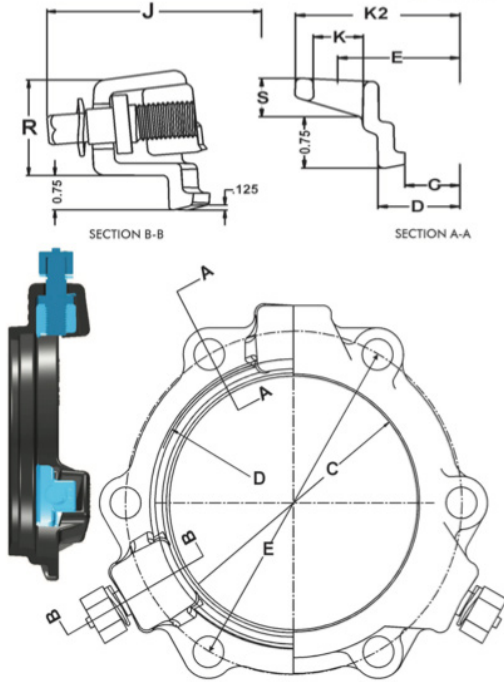

TUFGRIP® MJ Restraint Dimensions								
Size (In.)	C	D	E	K2	J	K	R	S
3	4.08	4.88	6.19	7.67	9.82	3/4	2.20	0.86
4	4.93	5.92	7.50	8.98	10.67	7/8	2.20	0.73
6	7.03	8.02	9.50	10.98	12.77	7/8	2.24	0.82
8	9.18	10.17	11.75	13.23	14.92	7/8	2.28	0.82
10	11.23	12.22	14.00	15.70	16.97	7/8	2.37	0.93
12	13.33	14.32	16.25	17.95	19.07	7/8	2.40	0.93
14	15.44	16.40	18.75	20.43	21.18	7/8	2.57	0.91
16	17.54	18.50	21.00	22.88	23.28	7/8	2.7	1.05
18	19.64	20.60	23.25	25.43	25.38	7/8	2.57	1.05
20	21.74	22.70	25.50	27.50	27.48	7/8	2.66	1.15
24	25.94	26.90	30.00	32.00	31.68	7/8	2.72	1.35
30	32.18	33.30	36.88	39.42	39.78	1-1/8	3.86	1.53
36	38.48	39.60	43.75	46.29	46.08	1-1/8	3.86	1.53
42	44.68	45.80	50.62	53.62	53.08	1-3/8	4.56	2.05
48	50.98	52.10	57.50	60.50	59.28	1-3/8	4.56	2.05

SERIES 1000 TLD-DUCTILE TUFGRIP® — APPLICATION CHART

Size (In.)	Part # – Gland Only	Part # – Gland Only	Wedge Qty.	T-head Bolt Qty.	Bolt Size	Gland weight (lbs.)	Weight (w/Acc.)	Pressure Rating	Pipe O.D.
	Hybrid	100% Domestic							
3	540823	600900	2	4	5/8" x 3"	6.5	10.5	350	3.96
4	515944	600905	2	4	3/4" x 3-1/2"	7.1	11.8	350	4.80
6	515968	600910	3	6	3/4" x 4"	11.2	18.8	350	6.90
8	515975	600915	3	6	3/4" x 4"	13.1	20.3	350	9.05
10	515982	600920	6	8	3/4" x 4"	26.0	32.5	350	11.10
12	515999	600925	8	8	3/4" x 4"	31.5	40.4	350	13.20
14	516231	600930	10	10	3/4" x 4-1/2"	43.3	53.6	350	15.30
16	516255	600935	12	12	3/4" x 4-1/2"	54.1	66.3	350	17.40
18	516279	600940	12	12	3/4" x 4-1/2"	59.8	72.2	250	19.50
20	516293	600945	14	14	3/4" x 4-1/2"	69.8	83.8	250	21.60
24	516316	600950	16	16	3/4" x 5"	90.4	106.9	250	25.80
30	539759	600955	20	20	1" x 7-1/2"	248	290	250	32.00
36	539764	600960	24	24	1" x 7-1/2"	277	327	250	38.30
42	539695	600961	28	28	1-1/4" x 8-1/2"	448	512	250	44.50
48	539699	600962	32	32	1-1/4" x 8-1/2"	519	597	250	50.80

ISO 9001-2015 Registered

Listed with Underwriters Laboratory

Factory Mutual Approved

STOP-LOOK:

- Extra length T-head bolts are provided with 30"-48" restraints to facilitate mechanical joint assembly.
- For UL/FM Approvals, 3"-12" were tested at 5° of deflection and 14"-24" were tested at 3° of deflection; all tests were to 700 psi.
- The Series 1000 TUF Grip is specified for use on ductile iron pipe, but can be used on some sizes of cast grey iron or pit cast pipe if the pipe is not severely corroded, is in sound condition and has an outside diameter compatible with the as provided dimensions.
- TUFGRIP 30"-48" provided with TRU-Lock™ mechanical joint gasket to ensure pressure ratings and safety factors are met.
- Installation and hydrostatic testing shall be in accordance with AWWA C600 and AWWA C651.
- Some vertical applications where the piping is partially buried may require additional restraint — contact Tyler Union.
- **Caution:** Pressure testing of piping systems restrained or un-restrained with insufficient backfill or bracing is not recommended.



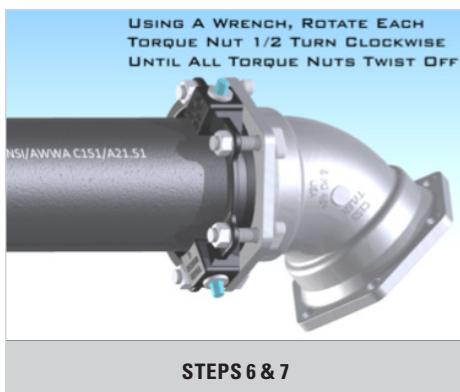

ASSEMBLY STEPS

SERIES 1000 FOR DUCTILE IRON PIPE

1. Ensure the beveled pipe end to be joined and mechanical joint socket is clean and free of debris. Slide the black TUFGrip onto the pipe to be restrained. The TUFGrip compression lip extension must be toward the beveled end of the pipe to be restrained.
2. Evenly lubricate the beveled pipe end, pipe wall exterior and inside surface of the MJ gasket with a lubricant that meets the requirements of AWWA C111. Now place the **MJ gasket over the plain beveled end of the pipe with the narrow edge of the tapered gasket toward the beveled end of the pipe to be restrained. ****NOTE:** For steel pipe with IPS diameter in sizes 3"–12", use of a MJ Transition gasket is required.
3. Fully insert the pipe end into the MJ socket pipe landing. Keeping the pipe straight, slide/push the MJ gasket firmly and evenly into the socket recess. Joint must be kept straight during assembly.
4. Push the TUFGrip compression lip extension evenly against the thick side of the gasket and insert T-head bolts with the T-head against the back side of the MJ fitting bolt flange. Use only T-head bolts and nuts that meet AWWA C111 requirements. Evenly hand-tighten the nuts on the T-head bolts making sure the gland is centered around the pipe and within the MJ socket. If joint deflection is needed, only deflect the pipe in the joint after hand tightening of all nuts is completed. *Joint deflection is 3° max for 3", 5° max for 4"–12", 2° max for 14"–16" and 1.5° max for 18"–48". ***NOTE:** Maximum deflection values provided apply with nominal pipe, fitting and restraint diameters.
5. Using a wrench, tighten the nuts on the T-head bolts a few turns at a time in an alternating or star pattern, maintaining equal spacing or distance between the TUFGrip bolt flange and face of the MJ socket bolt flange as the MJ gasket is compressed. The T-head bolt and nut torque requirement is 45–60 ft-lb for 3", 75–90 ft-lb for 4"–24", 100–120 ft-lb for 30"–36", and 120–150 ft-lb for 42"–48". **DO NOT OVER TORQUE!**
6. Hand-tighten the torque limiting nut attached to each TUFGrip wedge assembly in a clockwise direction with an alternating or star pattern until all gripping wedges are in contact with the pipe wall. Rotational direction of torque limiting nut is indicated by a recessed arrow on the face of the nut. With a wrench (box, socket or pneumatic), continue to tighten each torque nut half turn in an alternating or star pattern around the restraint until all torque limiting nuts twist off. **NEVER** turn a torque limiting nut more than half turn without turning the remaining torque nuts an equal amount!
7. When all torque limiting nuts twist off, the assembly of the mechanical joint is complete.



MJ TUFGRIP® TLD

SERIES 1000

FOR DUCTILE IRON PIPE

A Proven Third-Generation Mechanical Joint Restraint

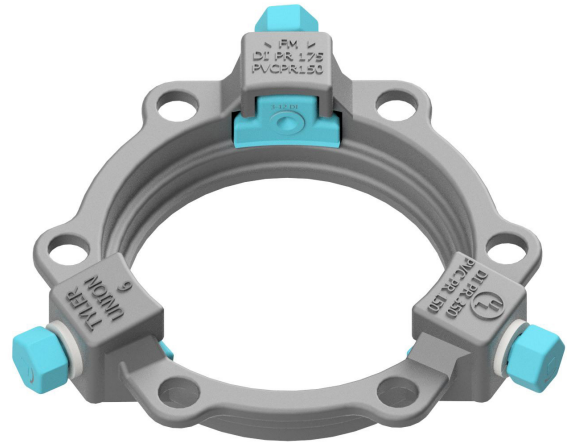

Tyler Union’s TUFGRip® restraint represents the culmination of 20 years of engineering and testing. As a third-generation restraint, TUFGRip is the best available technology in the waterworks market for use in restraining PVC, ductile and HDPE pipe.

FEATURES & ADVANTAGES

- Torque limiting nut on gripping wedge assembly twists off within a designed torque range, eliminating the need for specialized tools.
- Gripping wedge assembly pivots providing stronger engagement of pipe wall at lower torque requirement (45–60 ft-lb).
- Proven restraint technology utilizing fewer gripping wedges in frequently applied diameters, reducing trench time and project cost.
- Restraint’s heavy-duty construction and design eliminates the need for costly thrust blocks and tie rods.
- Suitable for potable and wastewater applications.

SPECIFICATIONS

- Designed and proven to restrain plain end ductile iron pipe conforming to ANSI/AWWA C151/A21.51 in diameters 3”–48” with a maximum surface hardness value of 250 Brinell at the engagement point of the wedges. (ISO 2531 for Ductile Iron Pipe specifies a maximum hardness value of 230 Brinell).
- Proven for use on heavy wall **Schedule 40 or greater steel pipe in sizes 3”–12” and on all sizes 3”–16” when pipe O.D. and wall thickness conforms to C151. ****Note:** IPS diameter steel pipe requires the use of an MJ Transition gasket.
- Restraint design conforms with applicable requirements of ANSI/AWWA C111, ANSI/AWWA C153 and ANSI/AWWA C110.
- Restraint engineered for securing plain end pipe to Mechanical joint fittings conforming to ANSI/AWWA C110, C111 and C153.
- Restraints rated for working water pressure of 350 psi and transitory surges of 100psi for 3”–16” and 250 psi for 18”–48”.
- Cast of ASTM A536 compliant 65-45-12 ductile iron complete with a cast on date code and country of origin for traceability.
- Restraints and all components are designed and proven for a 2:1 safety factor based on the pipe pressure rating.
- Restraint deflection rating when installed on nominal diameter pipe: 3° max for 3”, 5° max for 4”–12”, 2° max for 14”–16”, and 1.5° max for 18”–48”.
- Standard coating for non-domestic restraint is 4-6 mil of *alkyd resin baking enamel. Note: TUFBRond Coating available upon request.
- Gripping wedges are heat treated to a minimum 420 Brinell hardness.
- Gripping wedge, wedge collar bolt and twist-off torque limiting nut shall be E-coated.
- FM approved for 4”–12” applications and UL listed and approved for 3”–36” applications.
- Not recommended for use on plain end fittings.
- Color coded black for pipe type (ductile/*cast iron/*steel). ***Note:** Refer to the following pages for cast iron and steel pipe applications.

ISO 9001-2015 Registered		Listed with Underwriters Laboratory		Factory Mutual Approved	
Product Source/Type	Name of Project	Name of Contractor	Project Engineer	Spec. Section and/or Project No.	

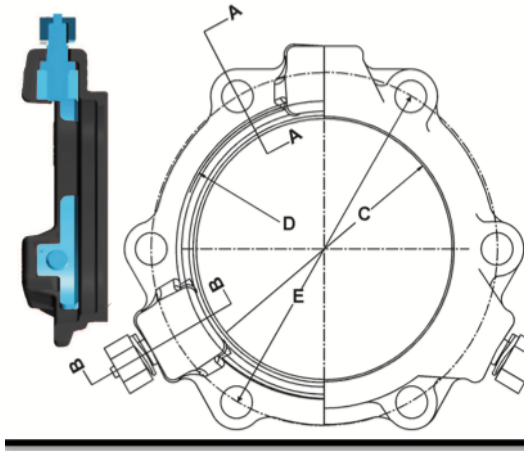

TUFGRIP® MJ Restraint Dimensions								
Size (In.)	C	D	E	K2	J	K	R	S
3	4.08	4.88	6.19	7.67	9.82	3/4	2.20	0.86
4	4.93	5.92	7.50	8.98	10.67	7/8	2.20	0.73
6	7.03	8.02	9.50	10.98	12.77	7/8	2.24	0.82
8	9.18	10.17	11.75	13.23	14.92	7/8	2.28	0.82
10	11.23	12.22	14.00	15.70	16.97	7/8	2.37	0.93
12	13.33	14.32	16.25	17.95	19.07	7/8	2.40	0.93
14	15.44	16.40	18.75	20.43	21.18	7/8	2.57	0.91
16	17.54	18.50	21.00	22.88	23.28	7/8	2.7	1.05
18	19.64	20.60	23.25	25.43	25.38	7/8	2.57	1.05
20	21.74	22.70	25.50	27.50	27.48	7/8	2.66	1.15
24	25.94	26.90	30.00	32.00	31.68	7/8	2.72	1.35
30	32.18	33.30	36.88	39.42	39.78	1-1/8	3.86	1.53
36	38.48	39.60	43.75	46.29	46.08	1-1/8	3.86	1.53
42	44.68	45.80	50.62	53.62	53.08	1-3/8	4.56	2.05
48	50.98	52.10	57.50	60.50	59.28	1-3/8	4.56	2.05

SERIES 1000 TLD-DUCTILE TUFGRIP® — APPLICATION CHART

Size (In.)	Part # – Gland Only	Wedge Qty.	T-head Bolt Qty.	Bolt Size	Gland weight (lbs.)	Weight (w/Acc.)	Pressure Rating	Pipe O.D.
	Non-Domestic							
3	113805	2	4	5/8" x 3"	6.5	10.5	350	3.96
4	113812	2	4	3/4" x 3-1/2"	7.1	11.8	350	4.80
6	113829	3	6	3/4" x 4"	11.2	18.8	350	6.90
8	113836	3	6	3/4" x 4"	13.1	20.3	350	9.05
10	113843	6	8	3/4" x 4"	26.0	32.5	350	11.10
12	113850	8	8	3/4" x 4"	31.5	40.4	350	13.20
14	113867	10	10	3/4" x 4-1/2"	43.3	53.6	350	15.30
16	113874	12	12	3/4" x 4-1/2"	54.1	66.3	350	17.40
18	113898	12	12	3/4" x 4-1/2"	59.8	72.2	250	19.50
20	113904	14	14	3/4" x 4-1/2"	69.8	83.8	250	21.60
24	113911	16	16	3/4" x 5"	90.4	106.9	250	25.80
30	461289	20	20	1" x 7-1/2"	248	290	250	32.00
36	461333	24	24	1" x 7-1/2"	277	327	250	38.30
42	461319	28	28	1-1/4" x 8-1/2"	448	512	250	44.50
48	461326	32	32	1-1/4" x 8-1/2"	519	597	250	50.80

ISO 9001-2015 Registered

Listed with Underwriters Laboratory

Factory Mutual Approved

STOP-LOOK:

- Extra length T-head bolts are provided with 30"-48" restraints to facilitate mechanical joint assembly.
- For UL/FM Approvals, 3"-12" were tested at 5° of deflection and 14"-24" were tested at 3° of deflection; all tests were to 700 psi.
- The Series 1000 TUFGRIP is specified for use on ductile iron pipe but can be used on some sizes of cast grey iron or pit cast pipe if the pipe is not severely corroded, is in sound condition and has an outside diameter compatible with the as provided dimensions.
- TUFGRIP 30"-48" provided with TRU-Lock™ mechanical joint gasket to ensure pressure ratings and safety factors are met.
- Installation and hydrostatic testing shall be in accordance with AWWA C600 and AWWA C651.
- Some vertical applications where the piping is partially buried may require additional restraint — contact Tyler Union.
- **Caution:** Pressure testing of piping systems restrained or un-restrained with insufficient backfill or bracing is not recommended.

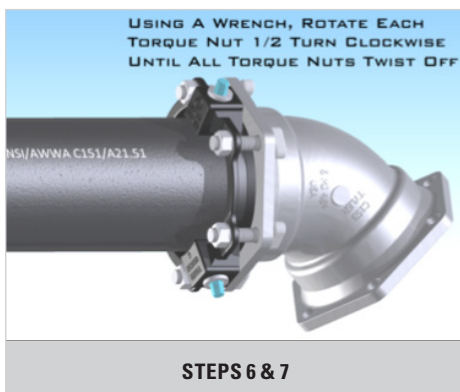

ASSEMBLY STEPS

SERIES 1000 FOR DUCTILE IRON PIPE

1. Ensure the beveled pipe end to be joined and mechanical joint socket is clean and free of debris. Slide the black TUFGrip onto the pipe to be restrained. The TUFGrip compression lip extension must be toward the beveled end of the pipe to be restrained.
2. Evenly lubricate the beveled pipe end, pipe wall exterior and inside surface of the MJ gasket with a lubricant that meets the requirements of AWWA C111. Now place the **MJ gasket over the plain beveled end of the pipe with the narrow edge of the tapered gasket toward the beveled end of the pipe to be restrained. ****NOTE:** For steel pipe with IPS diameter in sizes 3"–12", use of a MJ Transition gasket is required.
3. Fully insert the pipe end into the MJ socket pipe landing. Keeping the pipe straight, slide/push the MJ gasket firmly and evenly into the socket recess. Joint must be kept straight during assembly.
4. Push the TUFGrip compression lip extension evenly against the thick side of the gasket and insert T-head bolts with the T-head against the back side of the MJ fitting bolt flange. Use only T-head bolts and nuts that meet AWWA C111 requirements. Evenly hand-tighten the nuts on the T-head bolts making sure the gland is centered around the pipe and within the MJ socket. If joint deflection is needed, only deflect the pipe in the joint after hand tightening of all nuts is completed. *Joint deflection is 3° max for 3", 5° max for 4"–12", 2° max for 14"–16", and 1.5° max for 18"–48". ***NOTE:** Maximum deflection values provided apply with nominal pipe, fitting and restraint diameters.
5. Using a wrench, tighten the nuts on the T-head bolts a few turns at a time in an alternating or star pattern, maintaining equal spacing or distance between the TUFGrip bolt flange and face of the MJ socket bolt flange as the MJ gasket is compressed. The T-head bolt and nut torque requirement is 45–60 ft-lb for 3", 75–90 ft-lb for 4"–24", 100–120 ft-lb for 30"–36", and 120–150 ft-lb for 42"–48". **DO NOT OVER TORQUE!**
6. Hand-tighten the torque limiting nut attached to each TUFGrip wedge assembly in a clockwise direction with an alternating or star pattern until all gripping wedges are in contact with the pipe wall. Rotational direction of torque limiting nut is indicated by a recessed arrow on the face of the nut. With a wrench (box, socket or pneumatic), continue to tighten each torque nut half turn in an alternating or star pattern around the restraint until all torque limiting nuts twist off. **NEVER** turn a torque limiting nut more than half turn without turning the remaining torque nuts an equal amount!
7. When all torque limiting nuts twist off, the assembly of the mechanical joint is complete.

MJ TUFGRIP™ TLD SPLIT

SERIES 1000S

FOR DUCTILE IRON PIPE

A Proven Third-Generation Mechanical Joint Restraint

Tyler Union’s TUFGrip™ restraint represents the culmination of 20 years of engineering and testing. As a third-generation restraint, TUFGrip is the best available technology in the waterworks market for use in restraining PVC, ductile and HDPE pipe.

FEATURES & ADVANTAGES

- Torque limiting nut on gripping wedge assembly twists off within a designed torque range, eliminating the need for specialized tools.
- Gripping wedge assembly pivots providing stronger engagement of pipe wall at lower torque requirement (45–60 ft.-lbs.).
- Proven restraint technology utilizing fewer gripping wedges in frequently applied diameters, reducing trench time and project cost.
- Restraint’s heavy-duty construction and design eliminates the need for costly thrust blocks and tie rods.
- Suitable for potable and wastewater applications.



SPECIFICATIONS

- Designed and proven to restrain plain end ductile iron pipe conforming to ANSI/AWWA C151/A21.51 in diameters 4”–12” with a maximum surface hardness value of 250 Brinell at the engagement point of the wedges. (ISO 2531 for Ductile Iron Pipe specifies a maximum hardness value of 230 Brinell).
- Restraint design conforms with applicable requirements of ANSI/AWWA C111, ANSI/AWWA C153 and ANSI/AWWA C110.
- Restraint engineered for securing plain end pipe to mechanical joint fittings conforming to ANSI/AWWA C110, C111 and C153.
- Restraint rated for working water pressure of 350 psi for 4”–12” restraints.
- Cast of ASTM A536 compliant 65-45-12 ductile iron complete with a cast on date code and country of origin for traceability.
- Restraints and all components are designed and proven for a 2:1 safety factor based on the pipe pressure rating.
- Deflection rating when installed on AWWA C151 pipe with nominal diameter shall be 3° for 4”–12” restraints.
- Standard coating for Non-Domestic restraint is 4-6 mil of *alkyd resin baking enamel. ***Note:** TUF-Bond™ coatings available upon request.
- Gripping wedges are heat treated to a minimum 420 Brinell hardness.
- Gripping wedge, wedge collar bolt and twist-off torque limiting nut shall be e-coated.
- Not recommended for use on plain end fittings.
- Color coded black for pipe type (ductile pipe/*cast iron pipe). ***Note: Refer to the next page for cast iron pipe application.**

ISO 9001-2015 Registered

Product Source/Type	Name of Project	Name of Contractor	Project Engineer	Spec. Section and/or Project No.

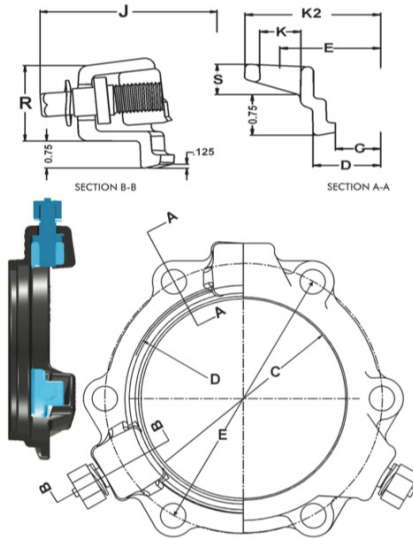

MJ TUFGRIP™ TLD SPLIT DIMENSIONS								
Size (In.)	C	D	E	K2	J	K	R	S
4	4.93	5.92	7.50	8.98	10.67	7/8	2.20	0.73
6	7.03	8.02	9.50	10.98	12.77	7/8	2.24	0.82
8	9.18	10.17	11.75	13.23	14.92	7/8	2.28	0.82
10	11.23	12.22	14.00	15.70	16.97	7/8	2.37	0.93
12	13.33	14.32	16.25	17.95	19.07	7/8	2.40	0.93

SERIES 1000 TLD-DUCTILE MJ TUFGRIP™ — APPLICATION CHART

Size (In.)	Part # – Gland Only		Wedge Qty.	T-head Bolt Qty.	Bolt Size	Gland Weight (lbs.)	Weight (w/Acc.)	*Pressure Rating	Pipe O.D. (Inches)
	Domestic	Non-Domestic							
4	N/A	495918	2	4	3/4" x 3-1/2"	7.1	11.8	350	4.80
6	N/A	495925	3	6	3/4" x 4"	11.2	18.8	350	6.90
8	N/A	495932	3	6	3/4" x 4"	13.1	20.3	350	9.05
10	N/A	495949	6	8	3/4" x 4"	26.0	32.5	350	11.10
12	N/A	495956	8	8	3/4" x 4"	31.5	40.4	350	13.20

*Note: The pressure ratings are rated working water pressures for the restraint.

****ADDITIONAL SERIES 2000S SPLIT TLP-PVC MJ TUFGRIP™ RESTRAINT RATINGS**

Size (In.)	AWWA C900			ASTM D2241		
	DR14	DR18	DR25	SDR17	SDR21	SDR26
4	305	235	150	250	200	160
6	305	235	150	250	200	160
8	305	235	150	250	200	160
10	305	235	150	250	200	160
12	305	235	150	250	200	-

**Note: Ratings for ordinary water works restraint applications with transitory surges only.

ISO 9001-2015 Registered

STOP-LOOK:

- The Series 1000S TUFGRIP is specified for use on ductile iron pipe but can be used on some sizes of cast grey iron or pit cast pipe as provided (pipe not severely corroded, in sound condition and with an outside diameter compatible with restraint "C" dimension).
- Installation and hydrostatic testing shall be in accordance with AWWA C600 and AWWA C651.

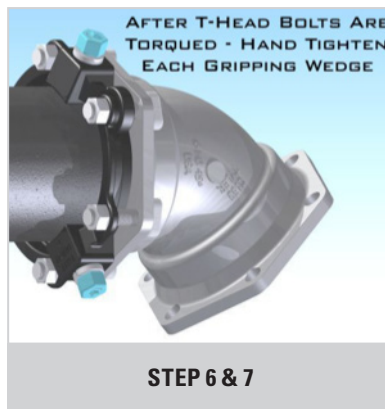
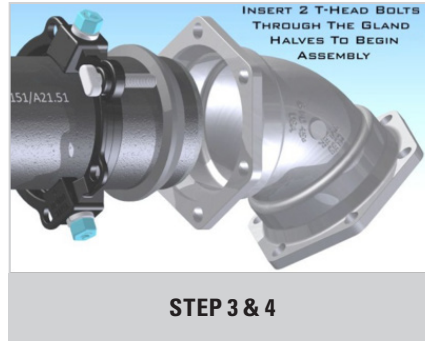

ASSEMBLY STEPS – SERIES 1000S TLD SPLIT – FOR DUCTILE IRON PIPE

1. Ensure the beveled pipe end to be joined and mechanical joint socket are clean and free of debris.
2. Lubricate the pipe end and exterior plus the inside surface of gasket with joint lubricant that meets the requirements of AWWA C111. Now place the MJ gasket over the plain beveled end of the pipe with the narrow edge of the tapered gasket toward the beveled end of the pipe to be restrained.
3. Fully insert the pipe end into the MJ socket pipe landing. Keeping the pipe straight, slide/push the gasket firmly and evenly into the MJ socket recess.
4. Place the two halves of the black TUFGrip around the pipe with the compression lip extension toward the MJ socket. Join the two restraint halves together with two T-head bolts. Use only T-head bolts, gaskets and nuts that meet AWWA C111 requirements.
5. With the two T-head bolts inserted through the restraint, push the TUFGrip lip extension evenly against the thick side of the MJ gasket. With the TUFGrip restraint against the gasket, the remaining T-head bolts are inserted with the T-head against the back of the MJ fitting bolt flange. Install two additional T-head bolts with nuts and hand tighten to secure the restraint to the fitting.
6. With the restraint secured to the fitting, remove the original assembly T-head bolts and reinsert with the T-head against the back of the MJ fitting bolt flange. Making sure the TUFGrip is centered around the pipe's wall, hand tighten all remaining T-head bolts and nuts. If joint deflection is needed, only deflect the pipe in the joint after hand tightening of all nuts is completed. Maximum joint deflection is 3° when pipe and fitting dimensions are nominal.
7. Using a wrench, tighten the nuts on the T-head bolts a few turns at a time in an alternating or star pattern. Maintain equal spacing between the TUFGrip bolt flange and the bolt flange of the MJ socket as the gasket is compressed. The T-head bolt and nut torque requirement is 75–90 ft.-lbs. for 4"–12" restraints.
DO NOT OVER TORQUE!
8. Hand tighten the torque limiting nut attached to the TUFGrip wedge assemblies in a clockwise direction with an alternating or star pattern until all gripping wedges are in contact with the pipe wall. Rotational direction of torque limiting nut is indicated by a recessed arrow on the face of the nut. With a wrench, continue to tighten each torque nut half turn in an alternating or star pattern until all torque limiting nuts twist off. **NEVER** turn a torque limiting nut more than half turn without turning the remaining torque nuts an equal amount!
9. When all torque limiting nuts twist off, the mechanical joint and restraint assembly is complete.

MJ TUFGRIP® TLP

SERIES 2000

FOR PVC & PVCU PIPE

A Proven Third-Generation Mechanical Joint Restraint

Tyler Union’s TUFGrip® restraint represents the culmination of 20 years of engineering and testing. As a third-generation restraint, TUFGrip is the best available technology in the waterworks market for use in restraining PVC, ductile and HDPE pipe.

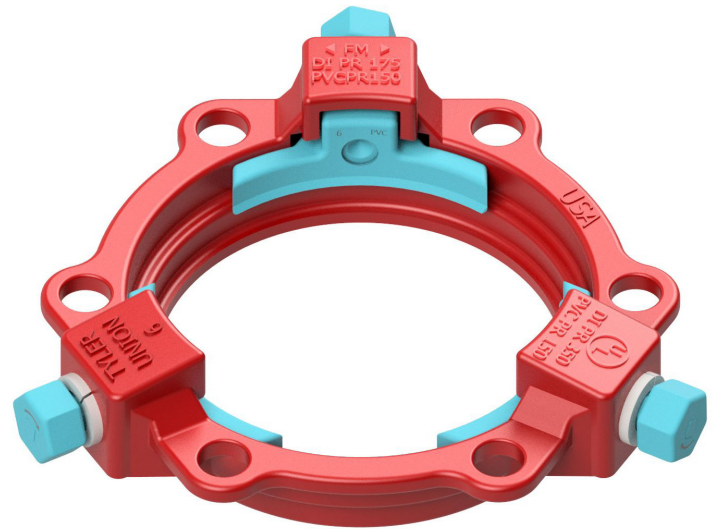

FEATURES & ADVANTAGES

- Torque limiting nut on gripping wedge assembly twists off within a designed torque range, eliminating the need for specialized tools.
- Gripping wedge assembly pivots providing stronger engagement of pipe wall at lower torque requirement (45–60 ft-lb).
- Proven restraint technology utilizing fewer gripping wedges in frequently applied diameters, reducing trench time and project cost.
- There is no washer or spacer to remove when installing restraints on 3”–12” ASTM D2241 PVC pipe with IPS outside diameter.
- Restraint’s heavy duty construction and design eliminates the need for costly thrust blocks and tie rods.
- Suitable for potable and wastewater applications.
- Approved for use on multiple classes of pipe — **additional pressure ratings and associated pipe classes provided on the following pages.**

SPECIFICATIONS

- Proven to restrain plain end PVC pipe in diameters 3”–36”, PVCU pipe in diameters 4”–12” and HDPE Pipe 3”–16”.
- Restraint design conforms to applicable requirements of ANSI/AWWA C111, ANSI/AWWA C153 and ANSI/AWWA C110.
- Restraint engineered for securing plain end pipe to mechanical joint fittings conforming to ANSI/AWWA C110, C111 and C153.
- Rated for working water pressure of 305 psi for 3”–12”, 235 psi for 14”–24”, 150 psi for 30” and 125 psi for 36” (**details on next page**).
- Cast of ASTM compliant 65-45-12 ductile iron complete with cast on date code and country of origin for traceability.
- Restraint and all components are designed and proven for a 2:1 safety factor based on the PVC, PVCU and HDPE pipe pressure rating. **Note:** Refer to the following pages for pressure rating.
- Restraint deflection rating when installed on nominal diameter pipe: 3° max for 3”–12”, 2° max for 14”–16” and 1.5° max for 18”–36”.
- Standard coating for domestic restraint is 4–6 mil of TUF-Bond™ (thermoset polyester for impact, corrosion and UV protection).
- Gripping wedge, wedge collar bolt and twist-off torque limiting nut shall be E-coated.
- FM approved for 4”–12” applications and UL listed and approved for 4”–12” applications.
- Color coded red for pipe type (C900 PVC/ *C909 PVCU/D2241 PVC). ***Note:** Refer to next page for C909 pipe applications.

ISO 9001-2015 Registered	Listed with Underwriters Laboratory	Factory Mutual Approved
--------------------------	-------------------------------------	-------------------------

Product Source/Type	Name of Project	Name of Contractor	Project Engineer	Spec. Section and/or Project No.



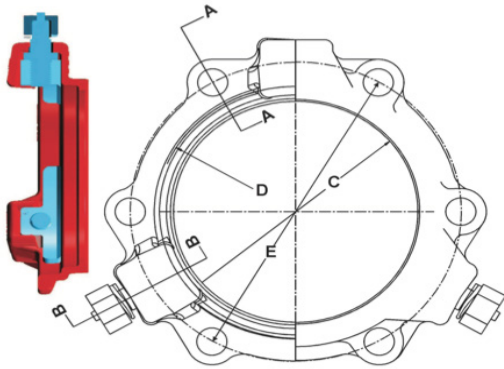
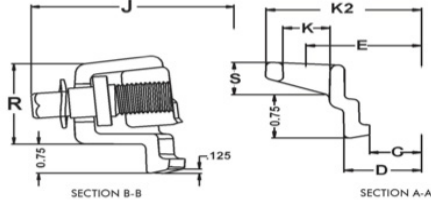

TUFGRIP® MJ Restraint Dimensions								
Size (In.)	C	D	E	K2	J	K	R	S
3	4.08	4.88	6.19	7.67	9.82	3/4	2.20	0.86
4	4.93	5.92	7.50	8.98	10.67	7/8	2.20	0.73
6	7.03	8.02	9.50	10.98	12.77	7/8	2.24	0.82
8	9.18	10.17	11.75	13.23	14.92	7/8	2.28	0.82
10	11.23	12.22	14.00	15.70	16.97	7/8	2.37	0.93
12	13.33	14.32	16.25	17.95	19.07	7/8	2.40	0.93
14	15.44	16.40	18.75	20.43	21.18	7/8	2.57	0.91
16	17.54	18.50	21.00	22.88	23.28	7/8	2.7	1.05
18	19.64	20.60	23.25	25.43	25.38	7/8	2.57	1.05
20	21.74	22.70	25.50	27.50	27.48	7/8	2.66	1.15
24	25.94	26.90	30.00	32.00	31.68	7/8	2.72	1.35
30	32.18	33.30	36.88	39.42	39.78	1-1/8	3.86	1.53
36	38.48	39.60	43.75	46.29	46.08	1-1/8	3.86	1.53

SERIES 2000 TLP-PVC TUFGRIP® — APPLICATION CHART

Size (In.)	Part # – Gland Only	Part # – Gland Only	Wedge Qty.	T-head Bolt Qty.	Bolt Size	Gland weight (lbs.)	Weight (w/Acc.)	Pressure Rating	Pipe O.D.
	Hybrid	100% Domestic							
3	CALL	N/A	2	4	5/8" x 3"	7.0	11.0	*305 / DR14	3.50
4	516002	601000	2	4	3/4" x 3-1/2"	8.3	12.2	*305 / DR14	4.50-4.80
6	516019	601005	3	6	3/4" x 4"	12.4	18.3	*305 / DR14	6.63-6.90
8	516026	601010	3	6	3/4" x 4"	14.9	20.8	*305 / DR14	8.63-9.12
10	516033	601015	6	8	3/4" x 4"	25.7	33.4	*305 / DR14	10.75-11.10
12	516040	601020	8	8	3/4" x 4"	34.1	42.0	*305 / DR14	12.75-13.20
14	516248	601025	10	10	3/4" x 4-1/2"	45.1	55.4	*235 / DR18	15.30
16	516262	601030	12	12	3/4" x 4-1/2"	56.2	68.4	*235 / DR18	17.40
18	516286	601035	12	12	3/4" x 4-1/2"	62.4	74.8	*235 / DR25	19.50
20	516309	601040	14	14	3/4" x 4-1/2"	72.9	86.9	*235 / DR25	21.60
24	516323	601045	16	16	3/4" x 5"	93.2	109.8	*235 / DR25	25.80
30	CALL	CALL	20	20	1" x 7-1/2"	251	293	*150 / DR25	32.00
36	CALL	CALL	24	24	1" x 7-1/2"	281	331	*125 / DR25	38.30

*Note: The pressure ratings are rated working water pressures for the restraint. See page 3 for additional ratings.

ISO 9001-2015 Registered

Listed with Underwriters Laboratory

Factory Mutual Approved

STOP-LOOK:

- Extra length T-head bolts are provided with 30"-36" restraints to facilitate mechanical joint assembly per AWWA C600.
- For UL/FM approvals, 3"-12" were tested to 755 psi, 14"-16" were tested to 755 psi and 18"-24" were tested to 535 psi.
- TUFGRIP 30"- 36" provided with TRU-Lock™ Mechanical joint gasket to ensure pressure rating & safety factors are met.
- Mechanical joint T-head bolt torques for C909 applications are as provided; *55-65 ft-lb for 4"-8" and *65-75 ft-lb for 10"-12" assembly. You must specify restraints are for C909 PVCO pipe upon order placement. Call for availability.
- Installation and hydrostatic testing shall be in accordance with AWWA C600 and AWWA C651.
- TUFGRIP 4"-24" restraints shall meet the requirements of ASTM F1674, current revision.
- **Caution:** Pressure testing of piping systems restrained or un-restrained with insufficient backfill or bracing is not recommended.



Tyler Union Waterworks Customer Service
 833-723-1135
customer.service@tylerunion.com
www.tylerunion.com



****ADDITIONAL SERIES 2000 TLP-TUF GRIP® RESTRAINT RATINGS**

Size (In.)	AWWA C900			AWWA C905			ASTM D2241			HDPE* AWWA C906				
	DR14	DR18	DR25	DR18	DR25	DR32.5	SDR17	SDR21	SDR26	DR7.3	DR9	DR11	DR13.5	DR17
3	-	-	-	-	-	-	250	200	160	254	200	160	128	100
4	305	235	165	-	-	-	250	200	160	254	200	160	128	100
6	305	235	165	-	-	-	250	200	160	254	200	160	128	100
8	305	235	165	-	-	-	250	200	160	254	200	160	128	100
10	305	235	165	-	-	-	250	200	160	254	200	160	128	100
12	305	235	165	-	-	-	250	200	-	254	200	160	128	100
14	-	-	-	235	165	125	-	-	-	254	200	160	128	100
16	-	-	-	235	165	125	-	-	-	254	200	160	128	100
18	-	-	-	200	165	-	-	-	-	-	-	-	-	-
20	-	-	-	200	165	-	-	-	-	-	-	-	-	-
24	-	-	-	165	165	125	-	-	-	-	-	-	-	-
30	-	-	-	-	165	125	-	-	-	-	-	-	-	-
36	-	-	-	-	125	125	-	-	-	-	-	-	-	-

****NOTE:** Pressure ratings for ordinary water works restraint application with transitory surges only; ****NOTE:** AWWA C909 PVCO restraint pressure rating is per the pressure rating listed on the pipe; ***NOTE:** HDPE applications require a separate stiffener ring. 3"-16" for DI OD Pipe and 3"-12" for IPS Pipe; assembly steps for (3"-12" ASTM D2241 IPS PVC), (4"-12" AWWA C909 PVCO) and (4"-36" AWWAC900).

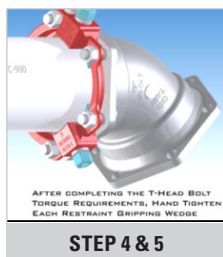
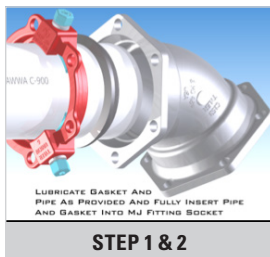

INSTALLATION

1. Ensure the beveled pipe end to be joined and mechanical joint socket is clean and free of debris. Slide the red TUFGRIP onto the beveled end of the pipe to be restrained. The TUFGRIP compression lip extension must be toward the beveled end of the pipe being restrained.
2. Evenly lubricate the beveled pipe end, exterior pipe wall and inside surface of the gasket with a lubricant that meets the requirements of AWWA C111. Now place the ****MJ** gasket over the plain beveled end of the pipe with the narrow edge of the tapered gasket toward the pipe end. ****NOTE:** Use MJ transition gasket with IPS diameter pipe.
3. Fully insert the beveled pipe end into the MJ socket pipe landing. Keeping the pipe straight in the MJ socket, slide/push the MJ gasket firmly and evenly into the MJ socket recess. Joint must be kept straight during assembly.
4. Push the TUFGRIP compression lip extension evenly against the thick side of the MJ gasket and insert all T-head bolts with nuts. Use only T-head bolts and nuts that meet AWWA C111 requirements. With the TUFGRIP restraint lip extension against the MJ gasket, evenly hand-tighten the nuts on the T-head bolts making sure the restraint body is centered on the pipe and within the MJ socket. If joint deflection is needed, deflect the pipe only after hand tightening of all nuts is completed. Joint deflection is 3° max for 3", 5° max for 4"-12", 2° max for 14"-16", 1.5° max for 18"-36". **NOTE:** Maximum deflection values provided apply with nominal pipe, fitting and restraint diameters.
5. Using a wrench, tighten the T-head bolts and nuts a few turns at a time in an alternating or star pattern. Maintain equal spacing or distance between the TUFGRIP bolt flange and the MJ socket bolt flange as the MJ gasket is compressed. Repeat the process in an alternating pattern for all T-head bolts and nuts. The T-head bolt and nut torque requirement is 45-60 ft-lb for 3", 75-90 ft-lb for 4"-24", and 100-120 ft-lb for 30"-36". **NOTE:** The C909 PVCO T-head bolt and nut torque is 55-65 ft-lb for 4"-8" and 65-75 ft-lb for 10"-12" restraints. **DO NOT OVER TORQUE T-HEAD BOLTS and NUTS WHEN ASSEMBLING PVC and PVCO PIPE!**
6. ****Hand-tighten** the torque limiting nuts attached to the TUFGRIP wedge assemblies in a clockwise direction with an alternating or star pattern until all gripping wedges are in contact with the pipe wall. Rotational direction of torque nut is indicated by a recessed arrow on the face of the nut. With a wrench (box, socket or pneumatic), continue to tighten each torque nut half turn in an alternating or star pattern around the restraint until all torque limiting nuts twist off. **NEVER** turn a torque limiting nut more than half turn without turning the remaining torque nuts an equal amount! ****NOTE:** For IPS and PVCO applications, ensure step 5 is completed before engaging wedges. Failure to comply will result in excessive pipe wall deflection and torque nuts will not twist off as designed.
7. When all torque limiting nuts twist off, the mechanical joint and restraint assembly are complete.



MJ TUFGRIP® TLP

SERIES 2000

FOR PVC & PVCU PIPE

A Proven Third-Generation Mechanical Joint Restraint

Tyler Union's TUFGrip® restraint represents the culmination of 20 years of engineering and testing. As a third-generation restraint, TUFGrip is the best available technology in the waterworks market for use in restraining PVC, ductile and HDPE pipe.



FEATURES & ADVANTAGES

- Torque limiting nut on gripping wedge assembly twists off within a designed torque range, eliminating the need for specialized tools.
- Gripping wedge assembly pivots providing stronger engagement of pipe wall at lower torque requirement (45–60 ft-lb).
- Proven restraint technology utilizing fewer gripping wedges in frequently applied diameters, reducing trench time and project cost.
- There is no washer or spacer to remove when installing restraints on 3"–12" ASTM D2241 PVC pipe with IPS outside diameter.
- Restraint's heavy duty construction and design eliminates the need for costly thrust blocks and tie rods.
- Suitable for potable and wastewater applications.
- Approved for use on multiple classes of pipe — **additional pressure ratings and associated pipe classes provided on the following pages.**

SPECIFICATIONS

- Proven to restrain plain end PVC pipe in diameters 3"–36", PVCU pipe in diameters 4"–12" and HDPE Pipe 4"–16".
- Restraint design conforms to applicable requirements of ANSI/AWWA C111, ANSI/AWWA C153 and ANSI/AWWA C110.
- Restraint engineered for securing plain end pipe to mechanical joint fittings conforming to ANSI/AWWA C110, C111 and C153.
- Rated for working water pressure of 305 psi for 3"–12", 235 psi for 14"–24", 150 psi for 30" and 125 psi for 36" (**details on next page**).
- Cast of ASTM compliant 65-45-12 ductile iron complete with cast on date code and country of origin for traceability.
- Restraint and all components are designed and proven for a 2:1 safety factor based on the PVC, PVCU and HDPE pipe pressure rating. **Note:** Refer to the following pages for pressure rating.
- Restraint deflection rating when installed on nominal diameter pipe: 3° max for 3"–12", 2° max for 14"–16", and 1.5° max for 18"–36".
- Standard coating for non-domestic restraint is 4–6 mil of alkyd resin baking enamel. Note: TUF-Bond™ available upon request.
- Gripping wedge, wedge collar bolt and twist-off torque limiting nut shall be E-coated.
- FM approved for 4"–12" applications and UL listed and approved for 4"–12" applications.
- Color coded red for pipe type (C900 PVC/ *C909 PVCU/D2241 PVC). ***Note:** Refer to next page for C909 pipe applications.

ISO 9001-2015 Registered		Listed with Underwriters Laboratory		Factory Mutual Approved	
Product Source/Type	Name of Project	Name of Contractor	Project Engineer	Spec. Section and/or Project No.	

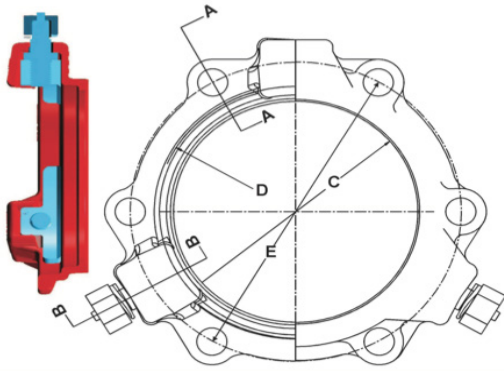
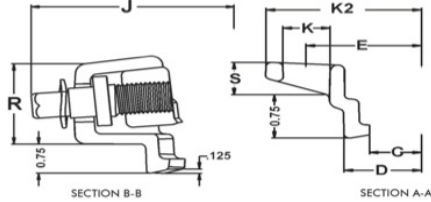

TUFGRIP® MJ Restraint Dimensions								
Size (In.)	C	D	E	K2	J	K	R	S
3	4.08	4.88	6.19	7.67	9.82	3/4	2.20	0.86
4	4.93	5.92	7.50	8.98	10.67	7/8	2.20	0.73
6	7.03	8.02	9.50	10.98	12.77	7/8	2.24	0.82
8	9.18	10.17	11.75	13.23	14.92	7/8	2.28	0.82
10	11.23	12.22	14.00	15.70	16.97	7/8	2.37	0.93
12	13.33	14.32	16.25	17.95	19.07	7/8	2.40	0.93
14	15.44	16.40	18.75	20.43	21.18	7/8	2.57	0.91
16	17.54	18.50	21.00	22.88	23.28	7/8	2.7	1.05
18	19.64	20.60	23.25	25.43	25.38	7/8	2.57	1.05
20	21.74	22.70	25.50	27.50	27.48	7/8	2.66	1.15
24	25.94	26.90	30.00	32.00	31.68	7/8	2.72	1.35
30	32.18	33.30	36.88	39.42	39.78	1-1/8	3.86	1.53
36	38.48	39.60	43.75	46.29	46.08	1-1/8	3.86	1.53

SERIES 2000 TLP-PVC TUFGRIP® — APPLICATION CHART

Size (In.)	Part # – Gland Only	Wedge Qty.	T-head Bolt Qty.	Bolt Size	Gland weight (lbs.)	Weight (w/Acc.)	*Pressure Rating	Pipe O.D.
	Non-Domestic							
3	113928	2	4	5/8" x 3"	7.0	11.0	*305 / DR14	3.50
4	113935	2	4	3/4" x 3-1/2"	8.3	12.2	*305 / DR14	4.50-4.80
6	113942	3	6	3/4" x 4"	12.4	18.3	*305 / DR14	6.63-6.90
8	113959	3	6	3/4" x 4"	14.9	20.8	*305 / DR14	8.63-9.12
10	113973	6	8	3/4" x 4"	25.7	33.4	*305 / DR14	10.75-11.10
12	113980	8	8	3/4" x 4"	34.1	42.0	*305 / DR14	12.75-13.20
14	113997	10	10	3/4" x 4-1/2"	45.1	55.4	*235 / DR18	15.30
16	114000	12	12	3/4" x 4-1/2"	56.2	68.4	*235 / DR18	17.40
18	114017	12	12	3/4" x 4-1/2"	62.4	74.8	*235 / DR25	19.50
20	114024	14	14	3/4" x 4-1/2"	72.9	86.9	*235 / DR25	21.60
24	114031	16	16	3/4" x 5"	93.2	109.8	*235 / DR25	25.80
30	461302	20	20	1" x 7-1/2"	251	293	*150 / DR25	32.00
36	461357	24	24	1" x 7-1/2"	281	331	*125 / DR25	38.30

*Note: The pressure ratings are rated working water pressures for the restraint. See page 3 for additional ratings.

ISO 9001-2015 Registered

Listed with Underwriters Laboratory

Factory Mutual Approved

STOP-LOOK:

- Extra length T-head bolts are provided with 30"-36" restraints to facilitate mechanical joint assembly per AWWA C600.
- For UL/FM Approvals, 3"-12" were tested to 755 psi, 14"-16" were tested to 755 psi and 18"-24" were tested to 535 psi.
- TUFGRIP 30"-36" provided with TRU-Lock™ mechanical joint gasket to ensure pressure rating and safety factors are met.
- Mechanical joint T-head bolt torques for C909 applications are as provided; *55-65 ft-lb for 4"-8" and *65-75 ft-lb for 10"-12" assembly. You must specify restraints are for C909 PVCO pipe upon order placement. Call for availability.
- Installation and hydrostatic testing shall be in accordance with AWWA C600 and AWWA C651.
- TUFGRIP 4"-24" restraints shall meet the requirements of ASTM F1674, current revision.
- **Caution:** Pressure testing of piping systems restrained or un-restrained with insufficient backfill or bracing is not recommended.

****ADDITIONAL SERIES 2000 TLP-TUF GRIP® RESTRAINT RATINGS**

Size (In.)	AWWA C900			AWWA C905			ASTM D2241			HDPE* AWWA C906				
	DR14	DR18	DR25	DR18	DR25	DR32.5	SDR17	SDR21	SDR26	DR7.3	DR9	DR11	DR13.5	DR17
3	-	-	-	-	-	-	250	200	160	254	200	160	128	100
4	305	235	165	-	-	-	250	200	160	254	200	160	128	100
6	305	235	165	-	-	-	250	200	160	254	200	160	128	100
8	305	235	165	-	-	-	250	200	160	254	200	160	128	100
10	305	235	165	-	-	-	250	200	160	254	200	160	128	100
12	305	235	165	-	-	-	250	200	-	254	200	160	128	100
14	-	-	-	235	165	125	-	-	-	254	200	160	128	100
16	-	-	-	235	165	125	-	-	-	254	200	160	128	100
18	-	-	-	200	165	-	-	-	-	-	-	-	-	-
20	-	-	-	200	165	-	-	-	-	-	-	-	-	-
24	-	-	-	165	165	125	-	-	-	-	-	-	-	-
30	-	-	-	-	165	125	-	-	-	-	-	-	-	-
36	-	-	-	-	125	125	-	-	-	-	-	-	-	-

****NOTE:** Pressure ratings for ordinary water works restraint application with transitory surges only; ****NOTE:** AWWA C909 PVC restraint pressure rating is per the pressure rating listed on the pipe; ****NOTE:** HDPE applications require a separate stiffener ring, 3"-16" for DI OD Pipe and 3"-12" for IPS Pipe; assembly steps for (3"-12" ASTM D2241 IPS PVC), (4"-12" AWWA C909 PVC) and (4"-36" AWWAC900).



INSTALLATION

1. Ensure the beveled pipe end to be joined and mechanical joint socket is clean and free of debris. Slide the red TUFGRIP onto the beveled end of the pipe to be restrained. The TUFGRIP compression lip extension must be toward the beveled end of the pipe being restrained.
2. Evenly lubricate the beveled pipe end, exterior pipe wall and inside surface of the gasket with a lubricant that meets the requirements of AWWA C111. Now place the ****MJ gasket** over the plain beveled end of the pipe with the narrow edge of the tapered gasket toward the pipe end. ****NOTE:** Use MJ transition gasket with IPS diameter pipe.
3. Fully insert the beveled pipe end into the MJ socket pipe landing. Keeping the pipe straight in the MJ socket, slide/push the MJ gasket firmly and evenly into the MJ socket recess. Joint must be kept straight during assembly.
4. Push the TUFGRIP compression lip extension evenly against the thick side of the MJ gasket and insert all T-head bolts with nuts. Use only T-head bolts and nuts that meet AWWA C111 requirements. With the TUFGRIP restraint lip extension against the MJ gasket, evenly hand-tighten the nuts on the T-head bolts, making sure the restraint body is centered on the pipe and within the MJ socket. If joint deflection is needed, deflect the pipe only after hand tightening of all nuts is completed. Joint deflection is 3° max for 3", 5° max for 4"-12", 2° max for 14"-16", 1.5° max for 18"-36". **NOTE:** Maximum deflection values provided apply with nominal pipe, fitting and restraint diameters.
5. Using a wrench, tighten the T-head bolts and nuts a few turns at a time in an alternating or star pattern. Maintain equal spacing or distance between the TUFGRIP bolt flange and the MJ socket bolt flange as the MJ gasket is compressed. Repeat the process in an alternating pattern for all T-head bolts and nuts. The T-head bolt and nut torque requirement is 45-60 ft-lb for 3", 75-90 ft-lb for 4"-24", and 100-120 ft-lb for 30"-36". **NOTE:** The C909 PVC T-head bolt and nut torque is 55-65 ft-lb for 4"-8" and 65-75 ft-lb for 10"-12" restraints. **DO NOT OVER TORQUE T-HEAD BOLTS and NUTS WHEN ASSEMBLING PVC and PVCO PIPE!**
6. ****Hand-tighten** the torque limiting nuts attached to the TUFGRIP wedge assemblies in a clockwise direction with an alternating or star pattern until all gripping wedges are in contact with the pipe wall. Rotational direction of torque nut is indicated by a recessed arrow on the face of the nut. With a wrench (box, socket or pneumatic), continue to tighten each torque nut half turn in an alternating or star pattern around the restraint until all torque limiting nuts twist off. **NEVER** turn a torque limiting nut more than half turn without turning the remaining torque nuts an equal amount! ****NOTE:** For IPS and PVCO applications, ensure step 5 is completed before engaging wedges. Failure to comply will result in excessive pipe wall deflection and torque nuts will not twist off as designed.
7. When all torque limiting nuts twist off, the mechanical joint and restraint assembly are complete.

MJ TUFGRIP® TLP SPLIT

SERIES 2000S

FOR PVC PIPE

A Proven Third-Generation Mechanical Joint Restraint

Tyler Union's TUFGrip® restraint represents the culmination of 20 years of engineering and testing. As a third-generation restraint, TUFGrip is the best available technology in the waterworks market for use in restraining PVC, ductile and HDPE pipe.

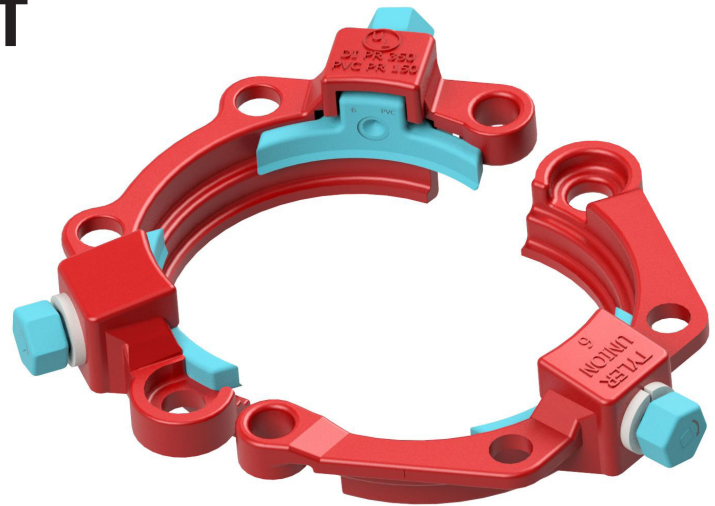

FEATURES & ADVANTAGES

- Unique split design assembles using standard T-bolts and without additional accessories in sizes 6"–12".
- Torque limiting nut on gripping wedge assembly twists off within a designed torque range eliminating the need for specialized tools.
- Gripping wedge assembly pivots providing stronger engagement of pipe wall at lower torque requirement (45–60 ft-lb).
- Proven restraint technology utilizing fewer gripping wedges in frequently applied diameters, reducing trench time and project cost.
- There is no washer or spacer to remove when installing restraints on 4"–12" ASTM D2241 PVC pipe with IPS outside diameter.
- Restraint's heavy duty construction and design eliminates the need for costly thrust blocks and tie rods.
- Suitable for potable and wastewater applications.
- Approved for use on multiple classes of pipe — **Additional pressure ratings and associated pipe classes provided on the next page.**

SPECIFICATIONS

- Proven to restrain plain end PVC pipe in diameters 4"–12".
- Restraint design conforms to applicable requirements of ANSI/AWWA C111, ANSI/AWWA C153, and ANSI/AWWA C110.
- Restraint engineered for securing plain end pipe to mechanical joint fittings, conforming to ANSI/AWWA C110, C111 and C153.
- Restraint rated for working water pressure of 305 psi for 4"–12" restraints (**details on next page**).
- Cast of ASTM A536 compliant 65-45-12 ductile iron complete with cast on date code and country of origin for traceability.
- Restraints and all components are designed and proven for a 2:1 safety factor based on the PVC pipe pressure rating.
- Restraint deflection rating when installed on nominal diameter pipe: 3° max for 4"–12".
- Standard coating for Non-Domestic restraint is 4-6 mil of *alkyd resin baking enamel. ***Note:** TUF-Bond™ coatings available upon request.
- Gripping wedge, wedge collar bolt and twist-off torque limiting nut shall be e-coated.
- Restraint body color coded red for pipe type (AWWA C900 PVC and ASTM D2241).

ISO 9001-2015 Registered

Product Source/Type	Name of Project	Name of Contractor	Project Engineer	Spec. Section and/or Project No.

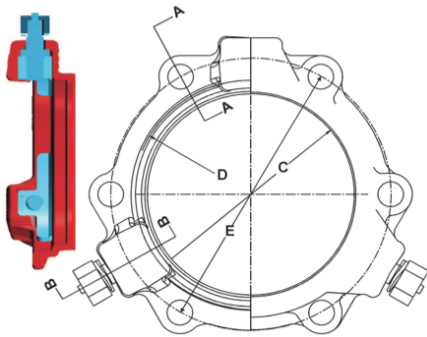
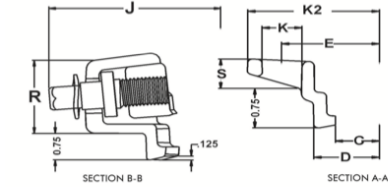

MJ TUFGRIP® TLP SPLIT DIMENSIONS								
Size (In.)	C	D	E	K2	J	K	R	S
4	4.93	5.92	7.50	8.98	10.67	7/8	2.20	0.73
6	7.03	8.02	9.50	10.98	12.77	7/8	2.24	0.82
8	9.18	10.17	11.75	13.23	14.92	7/8	2.28	0.82
10	11.23	12.22	14.00	15.70	16.97	7/8	2.37	0.93
12	13.33	14.32	16.25	17.95	19.07	7/8	2.40	0.93

SERIES 2000S TLP-PVC MJ TUFGRIP® — APPLICATION CHART

Size (In.)	Part # – Gland Only		Wedge Qty.	T-head Bolt Qty.	Bolt Size	Gland Weight (lbs.)	Weight (w/Acc.)	*Pressure Rating	Pipe O.D. (Inches)
	Domestic	Non-Domestic							
4	N/A	537052	2	4	3/4" x 3-1/2"	8.3	12.2	*305 / DR14	4.50-4.80
6	N/A	537069	3	6	3/4" x 4"	12.4	18.3	*305 / DR14	6.63-6.90
8	N/A	537076	3	6	3/4" x 4"	14.9	20.8	*305 / DR14	8.63-9.12
10	N/A	537083	6	8	3/4" x 4"	25.7	33.4	*305 / DR14	10.75-11.10
12	N/A	537090	8	8	3/4" x 4"	34.1	42.0	*305 / DR14	12.75-13.20

*Note: The pressure ratings are rated working water pressures for the restraint.

****ADDITIONAL SERIES 2000S SPLIT TLP-PVC MJ TUFGRIP® RESTRAINT RATINGS**

Size (In.)	AWWA C900			ASTM D2241		
	DR14	DR18	DR25	SDR17	SDR21	SDR26
4	305	235	150	250	200	160
6	305	235	150	250	200	160
8	305	235	150	250	200	160
10	305	235	150	250	200	160
12	305	235	150	250	200	-

**Note: Ratings are for ordinary water works restraint applications with transitory surges only.

NOTES

STOP-LOOK:

- Piping system installation and hydrostatic testing shall be in accordance with AWWA C600 and AWWA C65.
- TUFGRIP 4"-12" restraints shall meet the requirements of ASTM F1674, current revision.



ASSEMBLY STEPS – SERIES 2000S TLP SPLIT – FOR PVC PIPE

1. Ensure the beveled pipe end to be joined and mechanical joint socket are clean and free of debris.
2. Lubricate the pipe end and exterior plus the inside surface of gasket with joint lubricant that meets the requirements of AWWA C111. Now place the MJ gasket over the plain beveled end of the pipe with the narrow edge of the tapered gasket toward the beveled end of the pipe to be restrained.
3. Fully insert the pipe end into the MJ socket pipe landing. Keeping the pipe straight, slide/push the gasket firmly and evenly into the MJ socket recess. ****NOTE:** For IPS diameter pipe, use of an MJ transition gasket is required.
4. Place the two halves of the red TUFGrip around the pipe with the compression lip extension toward the MJ socket. Join the two restraint halves together with two T-head bolts. Use only T-head bolts, nuts and gasket that meet AWWA C111 requirements.
5. With the two T-head bolts inserted through the restraint, push the TUFGrip lip extension evenly against the thick side of the MJ gasket. With the TUFGrip restraint against the gasket, the remaining T-head bolts are inserted with the T-head against the back of the MJ fitting bolt flange. Install two additional T-head bolts with nuts, and hand tighten to secure the restraint to the fitting.
6. With the restraint secured to the fitting, remove the original assembly T-head bolts and reinsert with the T-head against the back of the MJ fitting bolt flange. Making sure the TUFGrip is centered around the pipe's wall, hand tighten all the remaining T-head bolts and nuts. If joint deflection is needed, only deflect the pipe in joint after hand tightening of all nuts is completed. Maximum joint deflection is 3° when pipe and fitting dimensions are nominal.
7. Using a wrench, tighten the nuts on the T-head bolts a few turns at a time in an alternating or star pattern. Maintain equal spacing between the TUFGrip bolt flange and the bolt flange of the MJ socket as the gasket is compressed. The T-head bolt and nut torque requirement is 75–90 ft.-lbs. for 4"–12" restraints. **DO NOT OVER TORQUE!**
8. Hand tighten the torque limiting nut attached to the TUFGrip wedge assemblies in a clockwise direction with an alternating or star pattern until all gripping wedges are in contact with the pipe wall. Rotational direction of torque nut is indicated by a recessed arrow on the face of the nut. With a wrench, continue to tighten each torque nut half turn in an alternating or star pattern until all torque limiting nuts twist off. NEVER tighten a torque limiting nut more than half turn without turning the remaining torque nuts an equal amount! ****NOTE:** For IPS applications, ensure step 7 is complete before engaging the wedges. Failure to comply will result in excessive pipe wall deflection and torque nuts will not twist off as designed.
9. When all torque limiting nuts twist off, the mechanical joint and restraint assembly are complete.

TUFGRIP™ DUAL WEDGE®

SERIES 1500

FOR PVC, DUCTILE AND HDPE PIPE

A Proven Third-Generation Mechanical Joint Restraint

Tyler Union’s TUFGrip™ restraint represents the culmination of 20 years of engineering and testing. As a third generation restraint, TUFGrip is the best available technology in the waterworks market for use in restraining PVC, ductile and HDPE pipe.



FEATURES & ADVANTAGES

- Torque limiting nut on gripping wedge assembly twists off within a designed torque range, eliminating the need for specialized tools.
- Gripping wedge assembly pivots providing stronger engagement of pipe wall at lower torque requirement (45–60 ft-lb).
- Proven restraint technology utilizing fewer gripping wedges in frequently applied diameters, reducing trench time and project cost.
- Restraint’s heavy duty construction and design eliminates the need for costly thrust blocks and tie rods.
- Approved for use on multiple classes of pipe — pressure ratings and associated pipe classes provided on the following pages.
- Suitable for potable and wastewater applications.
- Controlled wedge contour to accommodate contact circumference when assembled on different types of pipe.

SPECIFICATIONS

- Proven to restrain plain end PVC, ductile iron and HDPE pipe.
****Note:** IPS diameter pipe requires the use of an MJ Transition gasket.
- Restraint design conforms with applicable requirements of ANSI/AWWA C111, ANSI/AWWA C153 and ANSI/AWWA C110.
- Restraint engineered for securing plain end pipe to Mechanical joint fittings conforming to ANSI/AWWA C110, C111 and C153.
- Cast of ASTM A536 compliant 65-45-12 ductile iron complete with a cast on date code and country of origin for traceability.
- Restraints and all components are designed and proven for a 2:1 safety factor based on the pipe pressure rating.
- Restraint deflection rating when installed on nominal diameter pipe: 3° max for 4”–12”, 2° max for 14”–16” and 1.5° max for 18”–24”.
- Standard coating for Non-Domestic restraint is 4-6 mil of *alkyd resin baking enamel. ***Note:** TUF-Bond™ coatings available upon request.
- Gripping wedges are heat treated to a minimum 420 Brinell hardness.
- Gripping wedge, wedge collar bolt and twist-off torque limiting nut shall be E-coated.
- FM approved for 4”–16” applications and UL listed and approved for 4”–24” applications.
- Not recommended for use on plain end fittings.
- Color coded orange for use on multiple classes of pipe and to distinguish from traditional restraints.

ISO 9001-2015 Registered		Listed with Underwriters Laboratory		Factory Mutual Approved
Product Source/Type	Name of Project	Name of Contractor	Project Engineer	Spec. Section and/or Project No.

TUFGRIP™ DUAL WEDGE®

SERIES 1500

FOR PVC, DUCTILE AND HDPE PIPE

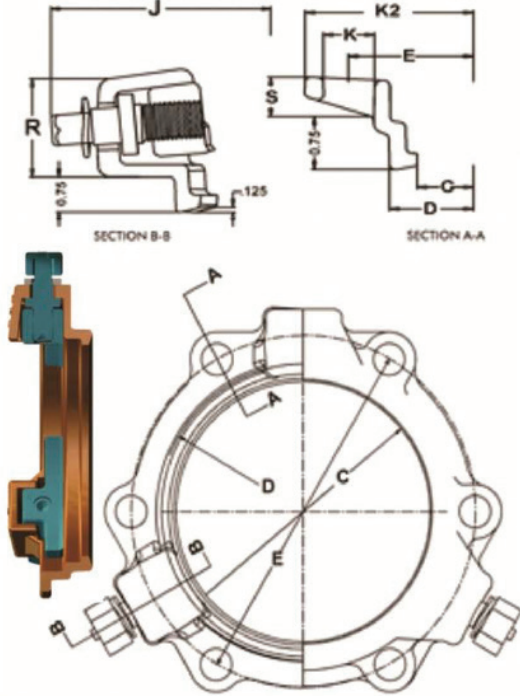

TUFGRIP™ MJ Restraint Dimensions								
Size (In.)	C	D	E	K2	J	K	R	S
4	4.93	5.92	7.50	8.98	10.67	7/8	2.20	0.73
6	7.03	8.02	9.50	10.98	12.77	7/8	2.24	0.82
8	9.18	10.17	11.75	13.23	14.92	7/8	2.28	0.82
10	11.23	12.22	14.00	15.70	16.97	7/8	2.37	0.93
12	13.33	14.32	16.25	17.95	19.07	7/8	2.40	0.93
14	15.44	16.40	18.75	20.43	21.18	7/8	2.57	0.91
16	17.54	18.50	21.00	22.88	23.28	7/8	2.7	1.05
18	19.64	20.60	23.25	25.43	25.38	7/8	2.57	1.05
20	21.74	22.70	25.50	27.50	27.48	7/8	2.66	1.15
24	25.94	26.90	30.00	32.00	31.68	7/8	2.72	1.35
30	32.18	33.30	36.88	39.42	39.78	1-1/8	3.86	1.53
36	38.48	39.60	43.75	46.29	46.08	1-1/8	3.86	1.53
42	44.68	45.80	50.62	53.62	53.08	1-3/8	4.56	2.05
48	50.98	52.10	57.50	60.50	59.28	1-3/8	4.56	2.05

SERIES 1500 TDW — TUFGRIP™ — APPLICATION CHART

Size (In.)	Part # – Gland Only Non-Domestic	Wedge Qty.	T-head Bolt Qty.	Bolt Size	Gland weight (lbs.)	Weight (w/Acc.)	DI Pipe	C-900 C-905	Pipe O.D.
4	602000	2	4	3/4" x 3-1/2"	7.1	11.8	350	*305/DR14	4.80
6	602005	3	6	3/4" x 4"	11.2	18.8	350	*305/DR14	6.90
8	602010	3	6	3/4" x 4"	13.1	20.3	350	*305/DR14	9.05
10	602015	6	8	3/4" x 4"	26.0	32.5	350	*305/DR14	11.10
12	602020	8	8	3/4" x 4"	31.5	40.4	350	*305/DR14	13.20
14	602025	10	10	3/4" x 4-1/2"	43.3	53.6	350	*235/DR18	15.30
16	602030	12	12	3/4" x 4-1/2"	54.1	66.3	350	*235/DR18	17.40
18	602035	12	12	3/4" x 4-1/2"	59.8	72.2	250	*235/DR25	19.50
20	602040	14	14	3/4" x 4-1/2"	69.8	83.8	250	*235/DR25	21.60
24	602045	16	16	3/4" x 5"	90.4	106.9	250	*235/DR25	25.80

NOTE: The pressure ratings are rated working water pressure for the restraint. See page 3 for additional ratings.

ISO 9001-2015 Registered

Listed with Underwriters Laboratory

Factory Mutual Approved

STOP-LOOK:

- For approvals, 4"-12" were tested at 3° of deflection, 14"-16" were tested at 2° of deflection and 18"-24" were tested at 1.5° of deflection; 4"-16" tests were to 700 psi and 18"-24" tests were to 500 psi.
- The Series 1500 TUFGRIP is specified for use on PVC, ductile and HDPE pipe, but can be used on some sizes of cast grey iron or pit cast pipe if the pipe is not severely corroded, is in sound condition and has an outside diameter compatible with the as provided dimensions.
- Installation and hydrostatic testing shall be in accordance with AWWA C600 and AWWA C651.

****SERIES 1500 TDW-TUF GRIP™ RESTRAINT RATINGS**

Size (In.)	Ductile Pipe	AWWA C900			AWWA C905			AWWA C909	ASTM D2241			HDPE* AWWA C906				
	C151/A21.51	DR14	DR18	DR25	DR18	DR25	DR32.5		SDR17	SDR21	SDR26	DR7.3	DR9	DR11	DR13.5	DR17
4	350	305	235	165	-	-	-	235/150*	250	200	160	254	200	160	128	100
6	350	305	235	165	-	-	-	235/150*	250	200	160	254	200	160	128	100
8	350	305	235	165	-	-	-	235/150*	250	200	160	254	200	160	128	100
10	350	305	235	165	-	-	-	235/150*	250	200	160	254	200	160	128	100
12	350	305	235	165	-	-	-	235/150*	250	200	160	254	200	160	128	100
14	350	-	-	-	235	165	125	-	-	-	-	254	200	160	128	100
16	350	-	-	-	235	165	125	-	-	-	-	254	200	160	128	100
18	250	-	-	-	200	165	125	-	-	-	-	-	-	-	-	-
20	250	-	-	-	200	165	125	-	-	-	-	-	-	-	-	-
24	250	-	-	-	165	165	125	-	-	-	-	-	-	-	-	-

NOTE: Pressure ratings for ordinary water works restraint applications with transitory surges only.
NOTE: AWWA C909 PVC0 restraint pressure rating is per the pressure.
NOTE: HDPE applications require a separate stiffener ring, 4"-16" for DI OD pipe and 4"-12" for IPS OD pipe rating listed on the pipe.



LUBRICATE GASKET AND PIPE AS PROVIDED AND FULLY INSERT PIPE AND GASKET INTO MJ FITTING HUB

STEP 1 & 2



INSERT AND HAND TIGHTEN T-HEAD BOLTS AND NUTS KEEPING PIPE STRAIGHT DURING INITIAL ASSEMBLY

STEP 3

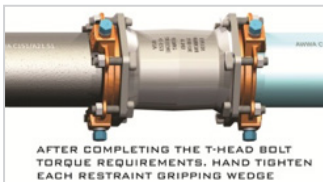

AFTER COMPLETING THE T-HEAD BOLT TORQUE REQUIREMENTS, HAND TIGHTEN EACH RESTRAINT GRIPPING WEDGE

STEP 4 & 5

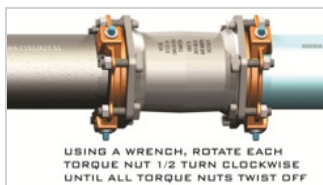

USING A WRENCH, ROTATE EACH TORQUE NUT 1/2 TURN CLOCKWISE UNTIL ALL TORQUE NUTS TWIST OFF

STEP 6 & 7

INSTALLATION

1. Ensure the beveled pipe end to be joined and mechanical joint socket is clean and free of debris. Slide the orange TUFGrip onto the beveled end of the pipe to be restrained. The TUFGrip compression lip extension must be toward the beveled end of the pipe being restrained.
2. Evenly lubricate the beveled pipe end, exterior pipe wall and inside surface of the gasket with a lubricant that meets the requirements of AWWA C111. Now place the **MJ gasket over the plain beveled end of the pipe with the narrow edge of the tapered gasket toward the pipe end. ****NOTE:** Use MJ transition gasket with IPS diameter pipe.
3. Fully insert the beveled pipe end into the MJ socket pipe landing. Keeping the pipe straight in the MJ socket, slide/push the MJ gasket firmly and evenly into the MJ socket recess. Joint must be kept straight during assembly.
4. Push the TUFGrip compression lip extension evenly against the thick side of the MJ gasket and insert all T-head bolts with nuts. Use only T-head bolts and nuts that meet AWWA C111 requirements. With the TUFGrip restraint lip extension against the MJ gasket, evenly hand-tighten the nuts on the T-head bolts making sure the restraint body is centered on the pipe and within the MJ socket. If joint deflection is needed, deflect the pipe only after hand tightening of all nuts is completed. Joint deflection is 3° max for 4"-12", 2° max for 14"-16", 1.5° max for 18"-24". **NOTE:** Maximum deflection values provided apply with nominal pipe, fitting and restraint diameters.
5. Using a wrench, tighten the T-head bolts and nuts a few turns at a time in an alternating or star pattern. Maintain equal spacing or distance between the TUFGrip bolt flange and the MJ socket bolt flange as the MJ gasket is compressed. Repeat the process in an alternating pattern for all T-head bolts and nuts. The T-head bolt and nut torque requirement is 75-90 ft-lb for 4"-24".
6. **NOTE:** The C909 PVC0 T-head bolt and nut torque is 55-65 ft-lb for 4"-8" and 65-75 ft-lb for 10"-12" restraints. **DO NOT OVER TORQUE T-HEAD BOLTS and NUTS WHEN ASSEMBLING PVC and PVC0 PIPE!**
7. ****Hand-tighten the torque limiting nuts attached to the TUFGrip wedge assemblies in a clockwise direction with an alternating or star pattern until all gripping wedges are in contact with the pipe wall. Rotational direction of torque nut is indicated by recessed arrow on the face of the nut. With a wrench (box, socket or pneumatic), continue to tighten each torque nut half turn in an alternating or star pattern around the restraint until all torque limiting nuts twist off. NEVER turn a torque limiting nut more than half turn without turning the remaining torque nuts an equal amount! ****NOTE:** For IPS and PVC0 applications, ensure step 5 is completed before engaging wedges. Failure to comply will result in excessive pipe wall deflection and torque nuts will not twist off as designed.**
8. When all torque limiting nuts twist off, the mechanical joint and restraint assembly are complete.

TUF FLANGE KIT

SERIES 4000

FOR PVC, DUCTILE AND HDPE PIPE

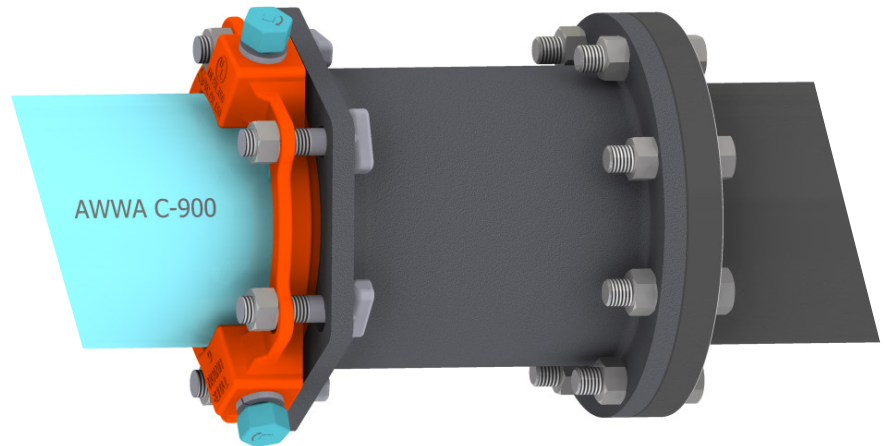

FEATURES & ADVANTAGES

- No special tools required for assembly.
- Plain end pipe doesn't need to be square cut.
- Accommodates pipe misalignment.
- Assembly uses industry standard MJ and Flange gaskets made of SBR (styrene butadiene rubber) per ANSI/AWWA C111.
- Suitable for potable and wastewater applications.

SPECIFICATIONS

- TUF FLANGE Kit restrains plain end PVC, ductile iron and HDPE pipe to flanged fittings, where the flange conforms to ANSI/AWWA C111, ANSI/AWWA C110.
- Design conforms with applicable requirements of ANSI/AWWA C111, ANSI/AWWA C110, ANSI/AWWA C153, ANSI B16.1 class 125.
- Material compliant with ASTM A536 ductile iron grade 65-45-12/70-50-05/60-42-10.
- Cast on date code with country of origin for traceability.
- Safety factor of 2:1. PVC and HDPE based on pipe pressure rating. PSI rating of 350 for sizes 4"-12".
- Restraint deflection rating when installed on nominal diameter pipe: 3° max for 4"-12".
- Standard coating for restraint gland is 4-6 mil of TUF Bond™ (thermoset polyester for impact, corrosion and UV protection). Adapter 2-3 mil of Black Asphaltic coating.
- UL and FM approved for 4"-12".
- Pipe can be field cut. Minimum insertion depth required for deflection.
- Not recommended for use on plain end fittings.
- T-bolts/nut are produced from high-strength, low-alloy steel per ANSI/AWWA C111/A21.11.
- Gripping wedges are heat treated to a minimum 420 Brinell hardness.

ISO 9001-2015 Registered



100% Domestic Available

Tyler Union Waterworks Customer Service
833-723-1135
customer.service@tylerunion.com
www.tylerunion.com

TYLER UNION[®]
Quality Waterworks Products

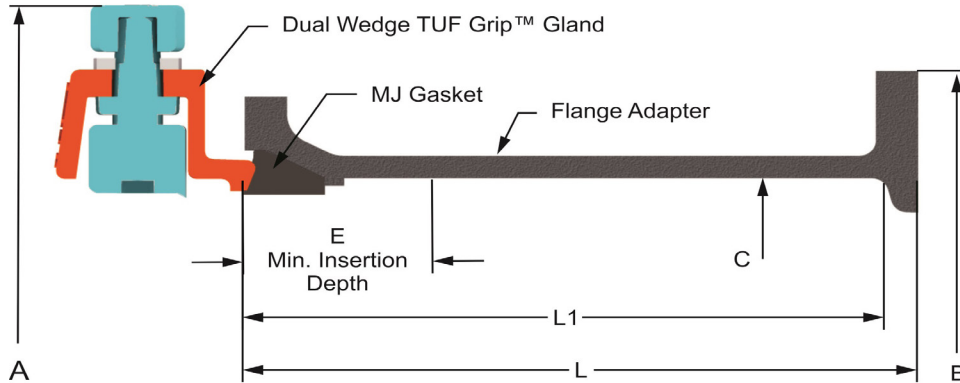

SERIES 4000 Dimensions and Application Chart

Size (Inches)	Pipe O.D.	A	B	C	E	L	L1	T-head Bolt Qty.	Bolt Size	Weight (w/Acc.)
4	4.50–4.80	10.67	9.0	5.35	2.5	10.0	9.5	4	¾" x 3-1/2"	45
6	6.63–6.90	12.77	11.0	7.45	2.5	10.0	9.5	6	¾" x 4"	60
8	8.63–9.12	14.92	13.5	9.65	2.5	10.0	9.5	6	¾" x 4"	75
10	10.75–11.10	16.97	16.0	11.81	2.5	10.0	9.5	8	¾" x 4"	103
12	12.75–13.20	19.07	19.0	13.89	2.5	10.0	9.5	8	¾" x 4"	130

*SERIES 4000 TUF FLANGE™ Pressure Ratings

Size (In.)	Ductile Pipe	AWWA C900				AWWA C909	HDPE** AWWA C906				
	C151/A21.51	DR14	DR18	DR25		DR7.3	DR9	DR11	DR13.5	DR17	
4	350	305	235	165	235/150*	254	200	160	128	100	
6	350	305	235	165	235/150*	254	200	160	128	100	
8	350	305	235	165	235/150*	254	200	160	128	100	
10	350	305	235	165	235/150*	254	200	160	128	100	
12	350	305	235	165	235/150*	254	200	160	128	100	

*Note: Pressure ratings for ordinary water works restraint application with transitory surges only.

*Note: AWWA C909 PVC0 restraint pressure rating is per the pressure rating listed on the pipe.

**Note: HDPE applications require a separate stiffener ring, 4"–12" for DI OD Pipe.



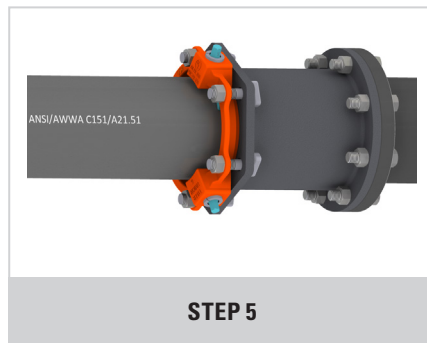
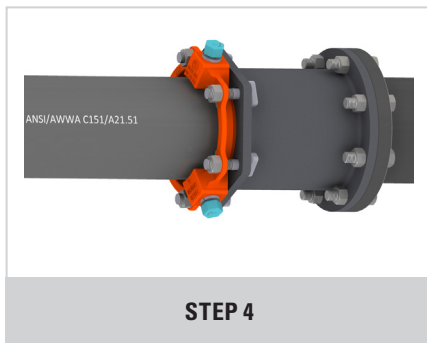
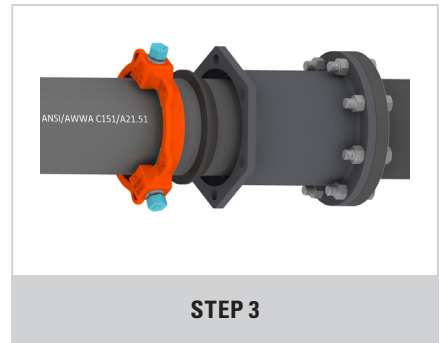

ASSEMBLY STEPS — SERIES 4000 TUF FLANGE™

1. Check the kit to ensure no parts are damaged or missing. Cut pipe to the length required. Remove debris and excess paint from pipe end and flange face using a wire brush or rag.
 2. Slide orange TUF Grip onto plain end of pipe. The TUF Grip compression lip extension must be toward the cut end of the pipe. Evenly lubricate the pipe end, exterior pipe wall and inside surface of the gasket with a lubricant that meets the requirements of AWWA C111. Now place the **MJ gasket over the plain end of the pipe with the narrow edge of the tapered gasket toward the pipe end. Slide the Flange Adapter over the plain end of the pipe. Minimum insertion depth required is 2.5" for 4"–12" in order to accommodate the maximum deflection of the joint.
 3. Connect the flange end with the adjacent flange making sure bolt holes line up. **NOTE:** Flange kit is not equipped with the TUF FLANGE™. Complete flange assembly before moving to step 4.
 4. Slide/push MJ gasket firmly and evenly into MJ socket recess. Push the TUF Grip compression lip extension evenly against the thick side of the MJ gasket and insert all T-head bolts with nuts. Use only T-head bolts and nuts that meet AWWA C111 requirements. With the TUF Grip restraint lip extension against the MJ gasket, evenly hand-tighten the nuts on the T-head bolts making sure the restraint
- body is centered on the pipe and within the MJ socket. Using a wrench, tighten the T-head bolts and nuts a few turns at a time in an alternating or star pattern. Maintain equal spacing or distance between the TUF Grip bolt flange and the MJ socket bolt flange as the MJ gasket is compressed. Repeat the process in an alternating pattern for all T-head bolts and nuts. The T-head bolt and nut torque requirement for restraints is 75–90 ft-lb for 4"–12".
5. **Hand-tighten the torque limiting nuts attached to the TUF Grip wedge assemblies in a clockwise direction with an alternating or star pattern until all gripping wedges are in contact with the pipe wall. Rotational direction of torque nut is indicated by a recessed arrow on the face of the nut. With a wrench (box, socket or pneumatic), continue to tighten each torque nut half turn in an alternating or star pattern around the restraint until all torque limiting nuts twist off. **NEVER** turn a torque limiting nut more than a half turn without turning the remaining torque nuts an equal amount! ****NOTE:** For PVC applications, ensure step 5 is completed before engaging wedges. Failure to comply will result in excessive pipe wall deflection, and torque nuts will not twist off as designed.
 6. When all torque limiting nuts twist off, the mechanical joint and restraint assemblies are complete.



SERIES 3000PP RESTRAINT

33U — PVC PIPE TO PIPE BELL TO SPIGOT RESTRAINT

KITS FOR 4"–36" APPLICATIONS: 4"–36" FOR DIOD & 4"–12" FOR IPS

Revised 2/2025 (Current revisions for the noted Standards apply)

FEATURES & ADVANTAGES

- Available in sizes 4"–36" (IPS PVC pipe restraints available in 4"–12" only).
- Restraints rated at the listed pressure on the PVC pipe with a 2:1 safety factor.
- Full 360° contact, no pipe distortion or point loading.
- To ease installation, restraints and pipe can be assembled outside the trench.
- Connecting rods, hex nuts, T-head bolts consist of low-alloy high strength steel and comply with applicable requirements of ANSI/AWWA C111/A21.11.
- Clamping bolts are SAE Grade 5 and comply to applicable requirements of ANSI/AWWA C111/A21.11.
- For easy identification, IPS pipe diameter clamps are grey and DI pipe diameter clamps are black.

SAMPLE SPECIFICATIONS

For use on water or wastewater piping systems subject to hydrostatic pressure and tested in accordance with ASTM D2774 or AWWA C600. All sizes of clamps are made of high-strength grade 65-45-12 ductile iron in accordance with the requirements and specifications of ASTM A536. Restraint clamps internal serrations are machined to exact tolerances. Restrainers approved per applicable requirements of ASTM F1674, current revisions apply. Standard restraint is provided with an alkyd resin baking enamel. The 3000PP kit includes 1) 2 each 3000C restrainers, 2) hex head bolts and hex nuts for restrainer assembly and 3) threaded restrainer connecting rods with hex nuts and flat washers where applicable.

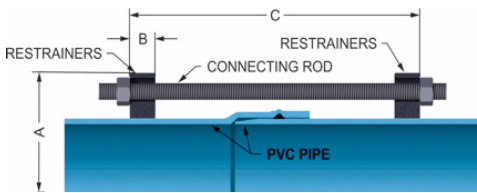

4"–12" Assembly

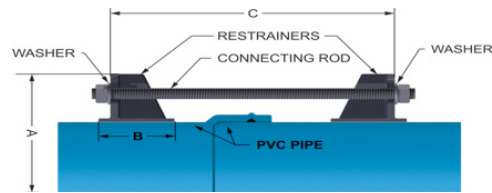

14"–36" Assembly

SERIES 3000PP RESTRAINT DIMENSIONS AND WEIGHTS

Nom Size	Series 3000PP For PVC Pipe With Ductile Pipe O.D.		Series 3000PP For PVC Pipe With IPS Pipe O.D.		*A	*B	*C Max.	Restraint Rods Connecting		Quantity, Sizing and Torque For Clamp Assembly Bolts (Torque in ft-lb)			WT
	Pipe Dia.	Part #	Pipe Dia.	Part #				Qty	Size	Qty	Size	Torque	
4	4.80	462422	4.50	462477	9.12	1.12	12.0	2	3/4 x 17	4	5/8 x 3-1/2	100 ft-lb	15
6	6.90	462439	6.63	462484	11.12	1.12	13.0	2	3/4 x 17	4	5/8 x 3-1/2	100 ft-lb	19
8	9.05	462446	8.63	462491	14.74	1.25	15.0	2	3/4 x 17	4	3/4 x 5	150 ft-lb	31
10	11.10	462453	10.75	462507	16.81	1.38	16.0	4	3/4 x 24	4	7/8 x 5	150 ft-lb	51
12	13.20	462460	12.75	462514	19.45	1.38	18.0	4	3/4 x 24	4	7/8 x 5	150 ft-lb	55
14	15.30	488033	N/A	N/A	22.54	4.00	24.0	6	3/4 x 30	8	7/8 x 6-1/2	150 ft-lb	138
16	17.40	488040	N/A	N/A	24.66	4.00	28.0	6	3/4 x 30	8	7/8 x 6-1/2	150 ft-lb	148
18	19.50	488057	N/A	N/A	26.64	5.06	28.0	8	3/4 x 30	8	1 x 8	175 ft-lb	207
20	21.60	488064	N/A	N/A	28.76	5.06	34.0	8	3/4 x 36	8	1-1/8 x 8-1/2	200 ft-lb	265
24	25.80	488071	N/A	N/A	33.98	5.20	34.0	12	3/4 x 36	8	1-1/8 x 8-1/2	225 ft-lb	407
30	32.00	498599	N/A	N/A	40.90	10.0	34.0	12	1 x 48	16	1-1/8 x 8-1/2	250 ft-lb	605
36	38.30	498605	N/A	N/A	48.00	10.0	34.0	12	1 x 48	16	1-1/8 x 8-1/2	250 ft-lb	670

NOTE: Approximate dimensions and weights.

SERIES 3000PP RESTRAINT

33U — PVC PIPE TO PIPE BELL TO SPIGOT RESTRAINT

KITS FOR 4"–36" APPLICATIONS:
4"–36" FOR DIOD & 4"–12" FOR IPS

Revised 2/2025

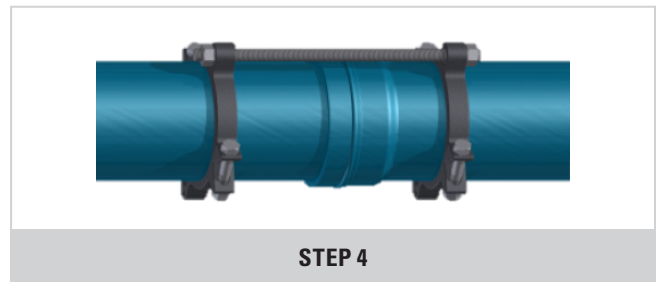
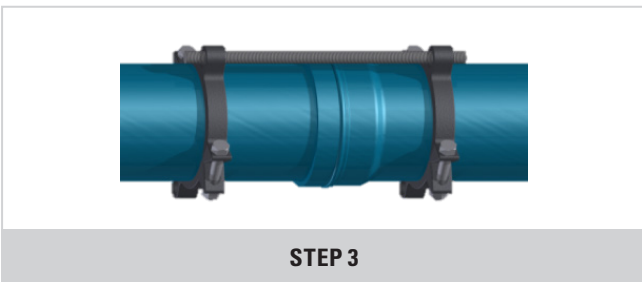
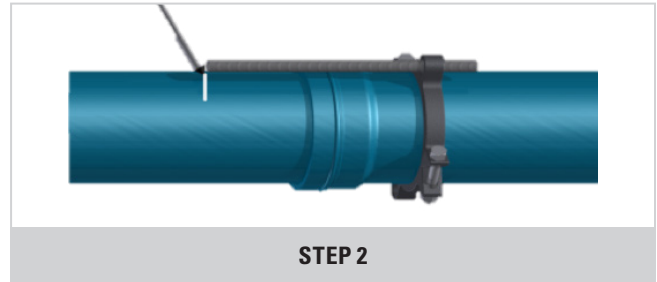
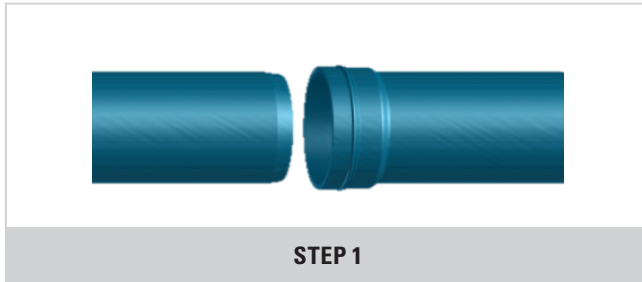

INSTALLATION INSTRUCTIONS FOR SIZES 4"–36" SERIES 3000PP

1. Assemble pipe per Figure 1 making sure the spigot end of the pipe is fully seated in the bell end of the pipe.
2. Assemble first restrainer on the bell end of the pipe joint and using one of the connecting rods (included) as a guide, mark the location for the spigot restrainer per Figure 2.
3. Assemble the spigot restrainer leaving sufficient threads on each end of the connecting rod to fully install washer (where provided) and fully engage nut per Figure 3. Tighten the restrainer clamp assembly bolts on each side evenly to the recommended torque maintaining even gaps between the clamp pads.
4. Connect both restrainers per Figure 4 utilizing the threaded restrainer connecting rods provided. Place a flat washer (where provided) over onto connecting rods and against the restrainer ear. Install hex nuts on the connecting rods and hand tighten all hex nuts to hand tight plus half turn. Do not overtighten connecting rod retaining hex nuts thus forcing the spigot further into the joint.

NOTE

- Suggested hex head bolt and nut *torque recommendations for assembly of the 3000C restrainers are as provided.
- For best results use the lower end of the recommended torque range for DR 41 and DR 51 PVC pipe.
- *100 ft-lb for 4"–6" / 150 ft-lb for 8"–12" / 150–200 ft-lb for 14"–16".
- 175–225 ft-lb for 18" / 200–250 ft-lb for 20" / 225–275 ft-lb for 24" / 250–300 ft-lb for 30"–36".

SERIES 3000 PVC TO MJ RESTRAINT

34U — PVC PIPE TO MJ FITTING RESTRAINT

KITS FOR 4"–36" APPLICATIONS: 4"–36" FOR DIOD & 4"–12" FOR IPS PIPE

Revised 2/2025 (Current revisions for the noted Standards apply)

Restraint of AWWA C900 PVC pipe in sizes 4"–36" to Mechanical joint AWWA C153/C110 ductile iron fittings. Restraint of *IPS diameter ASTM D2241 PVC pipe in sizes 4"–12" to Mechanical joint AWWA C153/C110 ductile iron fittings. ***NOTE:** Transition gasket required for IPS diameter ASTM D2241 PVC pipe. **NOTE:** 4"–16" restraints and accessories provided in boxed kits. Sizes larger than 16" will be provided with accessories kitted separate from the restraint and gland.

FEATURES & ADVANTAGES

- Available for PVC sizes 4"–36" for both ductile iron outside diameter (DIOD) pipe or iron pipe size (IPS) outside diameter pipe.
- Restraints and fasteners rated at the listed pressure on the PVC pipe and restraint shall have a 2:1 safety factor.
- Full 360° contact, no pipe distortion or point loading.
- Connecting T-head bolts or threaded rods, clamp assembly bolts and hex nuts consist of low-alloy high-strength steel and comply with applicable requirements of ANSI/AWWA C111/A21.11.
- System pressure rating *305 psi for DR14i, *235 psi for DR18, *165 psi for DR25.
- For easy identification, IPS pipe diameter clamps are grey and DI pipe diameter clamps are black.

SAMPLE SPECIFICATIONS

All clamps are made of high-strength grade 65-45-12 ductile iron in accordance with the requirements and specifications of ASTM A536. Clamps coated with alkyd resin baking enamel. Clamps provide 360 degree contact with the PVC pipe and internal serrations are machined to exact tolerances. Restrainers approved per applicable requirements of ASTM F1674, current revisions apply. Kits include 1 each 3000C restrainer, hex head clamping bolts and nuts for restrainer assembly, NSF approved MJ or transition gasket, mechanical joint gland and restraint to fitting T-head bolts or connecting threaded rods with hex nuts. For use on water or wastewater pipelines subject to hydrostatic pressure and tested in accordance with ASTM D2774 or AWWA C600 as applicable.

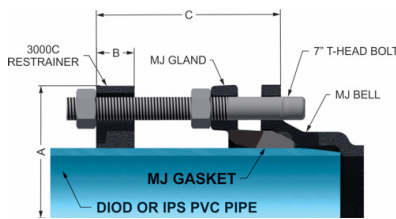

4"–12" Assembly

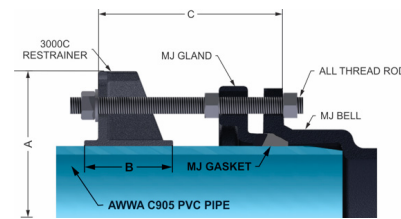

14"–36" Assembly

SERIES 3000PP RESTRAINT DIMENSIONS AND WEIGHTS

Nom Size	Series 3000MJ For PVC Pipe With Ductile Pipe O.D.		Series 3000MJ For PVC Pipe With IPS Pipe O.D.		*A	*B	*C Max.	Restraint Rods Connecting		Quantity, Sizing and Torque For Clamp Assembly Bolts (Torque in ft-lb)			*Kit (lbs.)
	Pipe Dia.	Part #	Pipe Dia.	Part #				Qty	Size	Qty	Size	Torque	
4	4.80	462576	4.50	512899	9.12	1.12	6.00	2	3/4 x 7	2	5/8 x 3-1/2	100 ft-lb	14
6	6.90	462583	6.63	512905	11.12	1.12	6.00	2	3/4 x 7	2	5/8 x 3-1/2	100 ft-lb	19
8	9.05	462590	8.63	512912	14.74	1.25	6.00	2	3/4 x 7	2	3/4 x 5	150 ft-lb	26
10	11.10	462606	10.75	512875	16.81	1.38	6.00	4	3/4 x 7	2	7/8 x 5	150 ft-lb	39
12	13.20	462613	12.75	512882	19.45	1.38	6.00	4	3/4 x 7	2	7/8 x 5	150 ft-lb	42
14	15.30	CALL	N/A	N/A	22.54	4.00	15.00	6	3/4 x 17	4	7/8 x 6-1/2	150 ft-lb	92
16	17.40	CALL	N/A	N/A	24.66	4.00	15.00	6	3/4 x 17	4	7/8 x 6-1/2	150 ft-lb	97
18	19.50	CALL	N/A	N/A	26.64	5.06	15.00	8	3/4 x 17	4	1 x 8	175 ft-lb	143
20	21.60	CALL	N/A	N/A	28.76	5.06	22.00	8	3/4 x 24	4	1-1/8 x 8-1/2	200 ft-lb	169
24	25.80	CALL	N/A	N/A	33.98	5.20	22.00	12	3/4 x 24	4	1-1/8 x 8-1/2	225 ft-lb	224
30	32.00	CALL	N/A	N/A	40.90	10.00	22.00	12	1 x 24	8	1-1/8 x 8-1/2	250 ft-lb	408
36	38.30	CALL	N/A	N/A	48.00	10.00	22.00	12	1 x 24	8	1-1/8 x 8-1/2	250 ft-lb	500

NOTE: Approximate dimensions and weights.

SERIES 3000 RESTRAINT

34U — PVC TO MJ RESTRAINT

KITS FOR 4"–36" APPLICATIONS:

4"–36" FOR DIOD & 4"–12" FOR IPS PIPE

Revised 2/2025

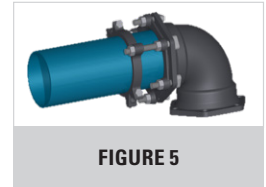
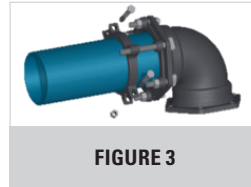
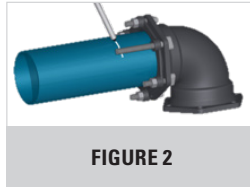
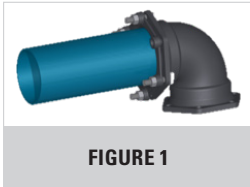

INSTALLATION INSTRUCTIONS FOR SIZES 4"–12" SERIES 3000MJ

1. Assemble the mechanical joint, install gasket, gland and T-head bolts per AWWA C600 standard, leave out the T-head bolt corresponding to the restrainer ears per Figure 1.
2. Per Figure 2, use a 7" T-head bolt (included) as a guide and mark the location on the pipe where the restrainer will be assembled.
3. Assemble restrainer per Figure 3, leaving sufficient threads on the end of the T-head bolt to fully engage nut.
4. Tighten the restrainer clamp assembly bolts on each side evenly to the recommended torque maintaining even gaps between the clamp pads. (100 ft-lb for 4"–6" and 150 ft-lb for 8"–12").
5. Connect the restrainer to fitting per Figure 5. Insert the 7" T-head bolt (bolt and 2 hex nuts provided) through the bolt flange installing a hex nut between the gland and restrainer. Tighten the hex nut up to the gland per AWWA C600 standard. Tighten the second hex nut up to the restrainer as show in Figure 5. Use additional hex nuts (not included) on the inside of the restrainer ear if joint is expected to contract.



INSTALLATION INSTRUCTIONS FOR SIZES 14"–36" SERIES 3000MJ

1. Assemble the mechanical joint, installing gasket, gland and T-head bolts per AWWA C600 standard, leave out the T-head bolt corresponding to the restrainer ears per Figure 1.
2. Per Figure 2, use a connecting rod (included) as a guide and mark the location on the pipe where the restrainer will be assembled.
3. Assemble restrainer per Figure 3, leaving sufficient threads on the end of the connecting rod to fully install washer and fully engage hex nut. Tighten the restrainer clamp assembly bolts on each side evenly to the recommended torque maintaining even gaps between the clamp pads (150–200 ft-lb for 14"–16", 175–225 ft-lb for 18", 200–250 ft-lb for 20", 225–275 ft-lb for 24", 250–300 ft-lb for 30" and 250–300 ft-lb for 36").
4. Connect restrainer to fitting per Figure 4. Inserting the rods through the restrainer ears (rod and 3 hex nuts provided for each ear), gland and fitting bolt hole. Install one hex nut behind fitting bell, one hex nut against the gland and one hex nut behind the restrainer ear against the washer. Tighten hex nut up to gland per AWWA C600 standard. Use additional hex nuts (not included) on the inside of the restrainer ear if joint is expected to contract.

SERIES 3000 PO TO PUSH-ON RESTRAINTS

35U — PVC PIPE TO PUSH-ON FITTING RESTRAINT KITS FOR 4"–12" APPLICATIONS: 4"–12" FOR DIOD & 4"–12" FOR IPS PIPE

Revised 2/2025 (Current revisions for the noted Standards apply)

Restrains AWWA C900 PVC pipe in sizes 4"–12" to Push-on AWWA C153 ductile iron fittings.

Restrains *IPS diameter PVC pipe in sizes 4"–12" to Push-on AWWA C153 ductile iron fittings. ***Transition gasket required**

FEATURES & ADVANTAGES

- Available for PVC sizes 4"–12" for both ductile iron outside diameter (DIOD) pipe or iron pipe size (IPS) outside diameter pipe.
- Restraints and fasteners rated at the listed pressure on the PVC pipe and restraint shall have a 2:1 safety factor.
- Full 360° contact, no pipe distortion or point loading.
- Connecting T-head bolts, clamp assembly bolts and hex nuts consist of low-alloy, high-strength steel and comply with applicable requirements of ANSI/AWWA C111/A21.11.
- System pressure rating *305 psi for DR14, *235 psi for DR18, *165 psi for DR25. ***Derated if all T-head bolts provided cannot be installed.**
- For easy identification, IPS pipe diameter clamps are grey and DI pipe diameter clamps are black.

SAMPLE SPECIFICATIONS

All clamps are made of high-strength grade 65-45-12 ductile iron in accordance with the requirements and specifications of ASTM A536. Clamps coated with alkyd resin-based baking enamel. Clamps provide 360 degree contact with the PVC pipe, and internal serrations are machined to exact tolerances. Restrainers approved per applicable requirements of ASTM F1674, current revisions apply. Kits include 1 each 3000C restrainer, 2 each hex head clamping bolts and nuts for restrainer assembly, and restraint to fitting connecting T-head bolts and hex nuts. For use on water or wastewater pipelines subject to hydrostatic pressure, and tested in accordance with ASTM D2774 or AWWA C600. ***Note: 10" and 12" fittings may have a single top/bottom restraining lug, contact Tyler Union for restraint pressure rating.**

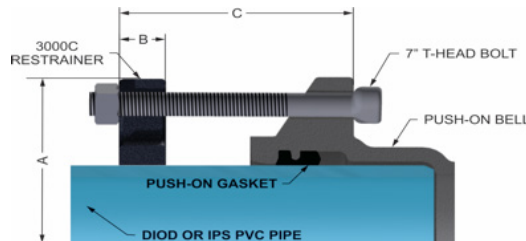

4"–12" Assembly

SERIES 3000PP RESTRAINT DIMENSIONS AND WEIGHTS													
Nom Size	Series 3000PO For PVC Pipe With Ductile Pipe O.D.		Series 3000PO For PVC Pipe With IPS Pipe O.D.		*A	*B	*C Max.	T-head Connecting Bolt		Quantity, Sizing and Torque For Clamp Assembly Bolts			*Kit (lbs.)
	Nom. Pipe O.D.	DIOD Part #	Nom. Pipe O.D.	IPS Part #				Qty	Size	Qty	Size	Torque	Wt.
4	4.80	462521	4.50	CALL	9.12	1.12	6.00	2	3/4 X 7	2	5/8 X 3 1/2	100 ft-lb	8
6	6.90	462538	6.63	CALL	11.12	1.12	6.00	2	3/4 X 7	2	5/8 X 3 1/2	100 ft-lb	10
8	9.05	462545	8.63	CALL	14.74	1.25	6.00	2	3/4 X 7	2	3/4 X 5	150 ft-lb	15
10	11.10	462552	10.75	CALL	16.81	1.38	6.00	4	3/4 X 7	2	7/8 X 5	150 ft-lb	24
12	13.20	462569	12.75	CALL	19.45	1.38	6.00	4	3/4 X 7	2	7/8 X 5	150 ft-lb	26

NOTE: Approximate dimensions

SERIES 3000 PO RESTRAINT
35U — PVC TO PUSH-ON RESTRAINT
KITS FOR 4"–12" APPLICATIONS:
4"–12" FOR DIOD & 4"–12" FOR IPS PIPE
 Revised 2/2025

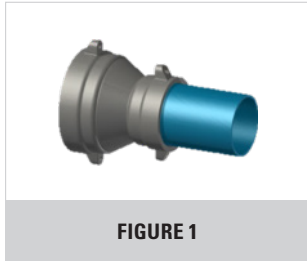

FIGURE 1

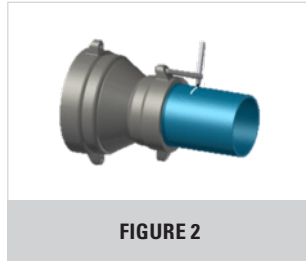

FIGURE 2

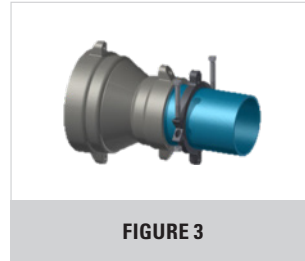

FIGURE 3

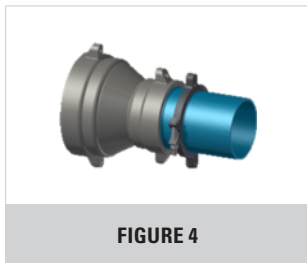

FIGURE 4

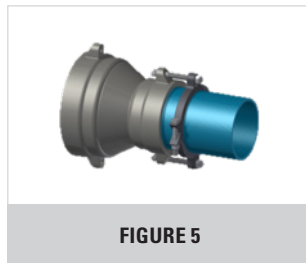

FIGURE 5

INSTALLATION INSTRUCTIONS FOR SIZES 4"–12" SERIES 3000PO:

- Figure 1, Push-On joint assembly per AWWA C600 — make sure the pipe spigot is beveled, ensure the fitting gasket seat is clean and dry prior to joint assembly. Insert the gasket into the fitting gasket seat and evenly lubricate the inside surface of the gasket only. Confirm the exterior pipe wall of the spigot end of the pipe is clean and free from raised or rough areas. Keeping the pipe straight with the fitting socket, insert the spigot end of the pipe fully against the pipe stop inside the fitting socket.
- Per Figure 2, use a 7" T-head bolt (included) as a guide and mark the location on the pipe where the restrainer will be assembled.
- Assemble restrainer per Figure 3, leaving sufficient threads on the end of the T-head bolt to fully engage nut.
- Tighten the restrainer clamp assembly bolts on each side evenly to the recommended torque maintaining even gaps between the clamp pads (100 ft-lb for 4"-6" and 150 ft-lb for 8"-12").
- Connect restrainer to fitting per Figure 5. Insert the 7" T-head bolt (bolts and hex nuts provided) through the fitting ear and tighten the hex nut up to the restrainer hand tight plus a half turn. Do not over tighten T-head bolts thus forcing the spigot further into the joint.

SURE STOP 350[®] GASKET

INSTANT JOINT RESTRAINT

McWane’s SURE STOP 350[®] Gaskets are a fast and easy way of restraining TYTON[®], TRIM TYTON[®] or TYTON JOINT[®] pipe valves and fittings. The gaskets are suitable for water, wastewater, fire protection and other related applications. Simply install the gasket in a TYTON JOINT[®] pipe, valve or fitting socket and assemble the joint in accordance with proper procedures, and the joint is restrained for working pressures up to 350 psi. The gaskets are available in sizes 3”–24”, and with a rating of 350 psi, they will meet or exceed the capabilities of ductile iron pipe, valves and fittings. SURE STOP 350[®] GASKETS are NSF 61 approved, UL listed and approved by FM Approvals. There is no need to use bolts, clamps, rods, thrust blocks or other restraining devices when you can use an easy push to restrain SURE STOP 350[®] GASKETS. SURE STOP 350[®]



GASKETS are produced and tested in accordance with ANSI/AWWA C111/A21.11 and have a 350 psi pressure rating. The gaskets have been successfully tested at a minimum of 700 psi to nationally recognized listing agency requirements, as witnessed by independent testing agencies (certificates available upon request).

Sure Stop 350 [®] Gasket Instant Joint Restraint				
Pipe Size	Circumference		Diameter	
Nominal	Maximum	Minimum	Maximum	Minimum
3	12-5/8"	12-1/4"	4.02"	3.90"
4	15-9/32"	14-29/32"	4.86"	4.74"
6	21-7/8"	21-1/2"	6.96"	6.84"
8	28-5/8"	28-1/4"	9.11"	8.99"
10	35-1/16"	34-11/16"	11.16"	11.04"
12	41-21/32"	41-9/32"	13.26"	13.14"
14	48-7/32"	47-13/16"	15.35"	15.22"
16	54-13/16"	54-13/32"	17.45"	17.32"
18	61-13/32"	61"	19.55"	19.42"
20	68"	67-19/32"	21.65"	21.52"
24	81-7/32"	80-13/16"	25.85"	25.72"

ISO 9001-2015 Registered	Listed with Underwriters Laboratory	Factory Mutual Approved
--------------------------	-------------------------------------	-------------------------

Product Source/Type	Name of Project	Name of Contractor	Project Engineer	Spec. Section and/or Project No.

McWane's Sure Stop 350® Gaskets are a fast and easy way of restraining TYTON JOINT® pipe, valves and fittings.

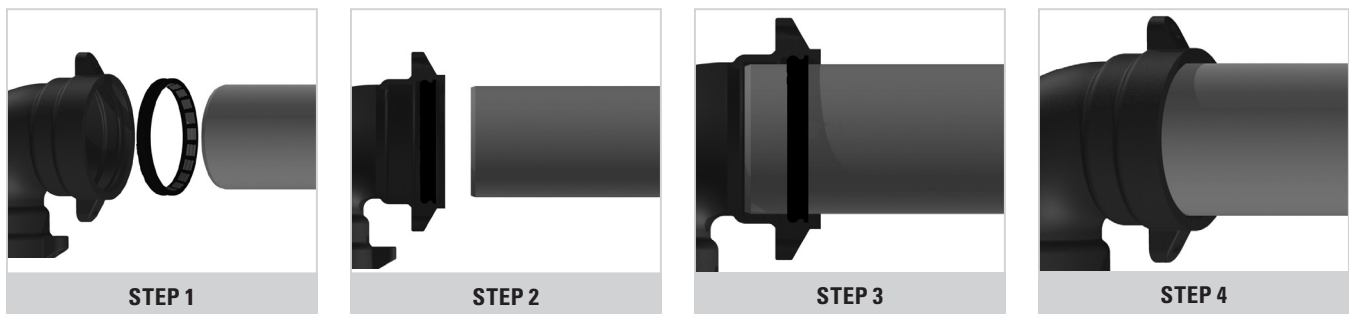

INSTALLATION

1. For ductile iron applications utilizing TYTON pipe, valves and fittings made to AWWA specifications.
2. In cold weather assembly, maintain the gasket temperature above 40° F.
3. The socket of the joint should be clean and free of debris (excess paint, cement, etc.).
4. Gasket should be properly seated in the bell socket.
5. Keep the pipe and joint in alignment during assembly. If installed out of alignment, the gasket can be pushed out of position, creating the potential for leaks and failures.
6. If deflection is wanted in the joint, deflect before fully inserting the joint.
7. Some extension of the joint will occur when pressurized. To avoid this, the joint should be pulled out after assembly to set the stainless teeth in the inserted pipe.
8. Once assembled, the joint can be disassembled using steel shims.
9. When cut pipe is used, the following steps are required:
 - Ensure that the spigot end is properly beveled.
 - Mark the joint depth on the spigot so it is clear when the joint is fully inserted.
 - Ensure that the pipe meets the required dimensional tolerances as noted in the table to the right.
10. Do not reuse SURE STOP 350® GASKETS as they may have been damaged during any previous installation or during removal.
11. Do not use SURE STOP 350® GASKETS to conduct electricity through the pipe joint as they could be damaged and fail.
12. Do not use SURE STOP 350® GASKETS in above-ground applications.
13. Do not use SURE STOP 350® GASKETS with thick coatings on the pipe exterior.

20U — ANSI/AWWA C116/A21.16 PROTECTIVE FUSION-BONDED EPOXY FOR AWWA FITTINGS

Revised 2/2025 (Current revisions for the noted Standards apply)

Tyler Union Waterworks standard applied coating thickness for protective fusion bonded epoxy (FBE) is 6–8 mil and our FBE is NSF61 and Annex G approved. Tyler Union Waterworks FBE water works fittings are coated internally and externally in accordance with the applicable requirements of ANSI/AWWA C116/A21.16. Section 4.3.2 of the ANSI/AWWA C116 standard provides that FBE mil thickness in the joint area shall not have a coating of less than 4 mil. Additionally, the standard advises it may be necessary to establish a limit for the maximum applied thickness in the joint areas.

Tyler Union Waterworks upon request at time of order placement, can provide FBE fittings with increased mil thickness. However, FBE thickness greater than 6–8 mil may interfere with the pipe to fitting fit and inhibit the sealing for a leakproof joint. For these reasons, Tyler Union Waterworks does not provide warranty for FBE-lined and coated fittings with greater than 8 mil thickness in the joint area.

Tyler Union Waterworks, FBE is tested and approved per Underwriters Laboratories UL262. Testing of FBE involves immersing coated parts in four aqueous solutions at 158°F and evaluate for blistering during 90-day continuous exposure period.

The solutions are distilled water, 2% sodium chloride in distilled water, distilled water with a pH adjusted to 4.0 using potassium hydrogen phthalate, and distilled water with pH adjusted to 10.0 using sodium carbonate. Tyler Union Waterworks FBE is also tested for blister resistance when immersed in acid, alkali, alcohol and hydrocarbons at room temperature over 90 days. Additional test data and recommended exposures for Tyler Union Waterworks FBE is as provided in Tables 1–3.

The ANSI/AWWA C116/A21.16 standard describes the use of protective fusion-bonded epoxy coatings as being utilized for the interior and exterior surfaces of ductile or gray iron fittings supplied for "water systems." Section 1.1 of the standard specifically provides that the standard does not cover instances where coatings are agreed upon by purchaser and manufacturer for sewer or other special applications. Though not always recommended for use in **sewer systems, FBE coated and lined fittings may be used in sewer applications conveying materials conforming to the properties as provided in Tables 2 and 3 on page 2.

TABLE #1

Test	Method	Conditions	Result
Abrasion Resistance	ASTM D4060	CS-17 wheels, 1000 cycles, 1 kg load	32 mg loss
Adhesion	ASTM D3359 — Method A	X-cut and tape	5A
Adhesion	ASTM D3359 — Method B	Crosshatch and tape	5B
Gloss, 60°	ASTM D523	N/A	70-85
Humidity Resistance	ASTM D2247	1000 hours at 100°F	No blisters or rusting
Impact	ASTM D2794	N/A	Pass 40 inch-lbs. direct
Pencil hardness	ASTM D3363	N/A	Pass 4H
Salt Spray	ASTM B117	1000 hours	No blisters or face rust, no scoreline creepage
Water Resistance	AWWA C550	90 days immersion at 70°C	Pass
Weather Resistance	ASTM G154	UVA-340, cycle 4 hrs UV at 60°C, 4 hrs condensation at 50°C	Chalks after 200 hours exposure

TABLE #2

Immersion Environments with the following chemicals (ambient temperature)

Aliphatic Hydrocarbons	Fresh Water
Calcium Chloride (10% solution)	Fuel Oil
Calcium Hydroxide (10% solution)	Hexane
Calcium Sulfate (saturated solution)	Kerosene
Calcium Carbonate (saturated solution)	Motor Oil
Distilled Water	Magnesium Sulfate (saturated solution)
Gasoline (unleaded)	Potassium Acetate (saturated solution)
Diesel Fuel	Soap Solutions
Sodium Chloride (5% solution)	Sodium Nitrate (10% solution)
Sodium Hydroxide (5% solution)	Trisodium Phosphate (5% solution)

TABLE #3

Splash and Spillage Environments against the following chemicals

Aromatic Hydrocarbons	Butanol
Ethanol	Hydrochloric Acid (5% solution)
Isopropyl Alcohol	Methanol
Sulfuric Acid (5% solution)	Toluene
Xylene	

Note

Due to the prescribed application methods of protective fusion-bonded epoxy and the combination of varying fitting diameters, recesses, raised lettering, tapping bosses and numerous radiused surfaces, the applied thickness of the FBE coating or lining may vary 1 to 2 mils over the coated surfaces of a fitting.

Final determination of the suitability of this product for your application shall be determined by the end user.

Additional types of epoxy coatings are available upon request at time of order placement. Please contact a Tyler Union Waterworks Customer Service representative to discuss the additional coating and lining options that are available.

21U — ANSI/AWWA C104/A21.4 CEMENT-MORTAR-ASPHALTIC MATERIAL FOR DUCTILE IRON FITTINGS

Revised 2/2025 (Current revisions for the noted Standards apply)

Tyler Union Waterworks Type I-II cement lining and asphaltic coating and lining provided with our ANSI/AWWA C104 cement-mortar lined ductile iron fittings are NSF-61, NSF-372 and Annex G approved. Tyler Union Waterworks lined and/or coated 2"–64" fittings are provided in accordance with and meet all the applicable terms and requirements of ANSI/AWWA C104/A21.4, ANSI/AWWA C110/A21.10, ANSI/AWWA C111/A21.11, ANSI/AWWA C153/A21.53, ANSI/AWWA C151/A21.51 and ASTM C150.

The standard specified thicknesses for cement and asphaltic linings for ductile iron fittings 2"–64" are as provided. Unless specified otherwise upon order placement, all cement-lined **fittings provided by Tyler Union Waterworks will be provided with an asphaltic lining and coating and the minimum thickness cement lining as provided for by ANSI/AWWA C104.

Fitting Size	Minimum AWWA Cement Lining Thickness	*Double Cement Lining Thickness	Minimum Asphaltic Thickness	Typical Tyler Union Asphaltic Thickness
2"–12" or 76–305mm	1/16" or 1.6mm	1/8" or 3.2mm	1 mil	2–4 mil
14"–24" or 356–610mm	3/32" or 2.4mm	3/16" or 4.8mm	1 mil	2–4 mil
30"–64" or 762–1600mm	1/8" or 3.2mm	1/4" or 6.4mm	1 mil	2–4 mil

*NOTE: You must specify double cement lining upon order placement.
 **NOTE: Mechanical joint solid sleeves, caps and plugs are provided with asphaltic coating only as per AWWA C110/C153 Section 4.4.3.

The asphaltic coating and lining utilized on the "inside" of pipe and fittings is to aid in the proper curing of the cement mortar lining as described in the ANSI/AWWA C104 standard, Section 4.10. The asphaltic coating and lining utilized on the "outside" of pipe and fittings is for cosmetic purposes and intended to provide some level of corrosion protection prior to being installed.

The purpose of the cement lining on the inside of ductile iron waterworks fittings is to reduce the degree of tuberculation

(buildup) or corrosion on the fitting wall. Tuberculation or corrosion of the fitting wall is minimized in soft or acid water as the cement lining creates a high pH at the fitting wall. Beginning in 1995, the asphaltic lining for the inside of fittings is no longer required by AWWA but is recommended in instances where the pH of the water is less than 6.0 or greater than 10.0.

Additional Applications and Ratings for Cement-Mortar and Asphaltic Materials	
Cement without asphaltic coating: Service to *212°F max.	Cement with asphaltic coating: Service to 150°F max.
Asphalt only: Air service to 150°F max.	Cement w/o asphalt: sea water, non-septic gravity sewer, reclaim water
*NOTE: For systems designed to convey materials above 150°F, contact Tyler Union for adjusted pressure rating of the fittings.	

ANSI/AWWA C104/A21.4 — Approved Field Repair Method for Cement-Mortar Lined Fittings
1. Remove the damaged portion or area of the lining down to the metal surface, making sure any remaining lining edges are undercut slightly or perpendicular to the fitting wall.
2. Clean the surface of loose debris and any tuberculation or corrosion where the lining was removed.
3. Prepare a stiff mortar from a mixture of sand, cement and water making sure the mix contains no less than one part cement to two parts sand by volume.
4. Thoroughly wet the cut out area and the adjoining lining.
5. Apply mortar mix and trowel smooth with the adjoining lining.
6. After any surface water has evaporated, but while the patch is still moist, cure the lining as provided.
7. The repaired cement lining can be kept moist by seal (asphaltic) coating or with the use of **wetted burlap bags placed over the entire waterway opening of the fitting or access point. Once the mortar is applied to the fitting, apply the seal coat by spraying or brushing on the seal coat within 5 to 15 minutes after any surface water has evaporated.
<p>** Note: (1) In instances where seal coat is not used, cure cement as provided for 24 hours after application. (2) In cold weather, the patched area should be protected from freezing. (3) If seal coat paint is used during field repair, allow a cure time of 48 hours after the seal coat is applied before placing fitting back in service.</p>

Tyler Union Waterworks — Approved Field Repair for Asphaltic Coating of Interior and Exterior Fitting Surfaces
1. Paint repair to the fitting body or mechanical joint includes use of a hand steel bristle brush to remove loose corrosion. Wipe area free of dust or debris with a cloth suitable for the task and recoat exterior areas of the fitting with the paint provided as needed using a standard paint brush sized for the task.
2. Recoating of the cement lining is achieved by wiping the lining with a cloth to remove any loose paint or debris and then apply paint using a standard size paint brush suitable for the task applying paint to affected areas as needed.

Note
Pressure washing of cement linings is not recommended. However, if required, contact your Tyler Union representative for instructions before proceeding. Failure to follow these instructions or provide suitable supporting documentation will void the warranty on our lining.

22U — ANSI/AWWA C110/A21.10 MECHANICAL JOINT FULL BODY DUCTILE IRON FITTINGS

Revised 2/2025 (Current revisions for the noted Standards apply)

SIZES:	2"–48"
STANDARDS:	ANSI/AWWA C110/A21.10, NFPA 13/24, 3"–12" UL listed and approved (File - Tyler Union)
MATERIAL:	Cast of ASTM A536 qualified ductile iron. Date code is cast on and required for traceability.
PRESSURE RATING:	*Flanged fittings rated at 250 psi. Mechanical joints 2"–24" rated at 350 psi and 30"–48" at 250 psi. *Note: With rubber annular ring flange gasket, 2"–24" Flanged fittings can be rated at 350 psi. Note: Wyes over 12" are not pressure rated. Contact Tyler Union for rating in your application.
DEFLECTION:	Joint deflection 5° max for 2"–12" and 3° max for 14"–48". Reduces by 50% at nominal pipe & fitting diameters.
NSF-61 & NSF372:	Meets all requirements, including Annex G, Tyler Union's Underwriters Laboratory listing MH16439.
ASPHALT COATING:	Per ANSI/AWWA C104/A21.4 and ANSI/AWWA C110/A21.10.
CEMENT LINING:	Per ANSI/AWWA C104/A21.4, with double cement lining available upon request.
EPOXY COATING:	Fusion-bonded epoxy per ANSI/AWWA C116/A21.16. Additional coatings available upon request.
BARE FITTINGS:	Available upon request.
FASTENERS:	High-strength low-alloy weathering steel per ANSI/AWWA C111/A21.11 and ASTM A242.
INSTALLATION:	Install per AWWA C600/C651 using pipe conforming to ANSI/AWWA C151/A21.51 or AWWA C900.

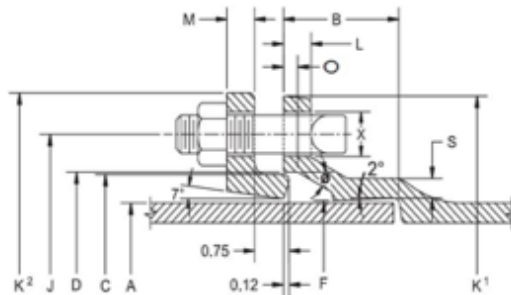

NOMINAL JOINT DIMENSIONS IN INCHES

Size (In.)	A Dia. DI Pipe	B Hub Depth	C Dia. GLAND	D Dia.	F Dia.	Ø	X	J Dia. GLAND	K' Dia.	K² Dia. GLAND	L	M GLAND	O	S	Qty. Bolts
2	2.51	2.50	3.39	3.50	2.61	28°	3/4	4.75	6.25	6.25	0.73	0.62	0.31	0.44	2
3	3.96	2.50	4.84	4.94	4.06	28°	3/4	6.19	7.69	7.69	0.94	0.62	0.31	0.52	4
4	4.80	2.50	5.92	6.02	4.90	28°	7/8	7.50	9.12	9.12	1.00	0.75	0.31	0.65	4
6	6.90	2.50	8.02	8.12	7.00	28°	7/8	9.50	11.12	11.12	1.06	0.88	0.31	0.70	6
8	9.05	2.50	10.17	10.27	9.15	28°	7/8	11.75	13.37	13.37	1.12	1.00	0.31	0.75	6
10	11.10	2.50	12.22	12.34	11.20	28°	7/8	14.00	15.69	15.62	1.19	1.00	0.31	0.80	8
12	13.20	2.50	14.32	14.44	13.30	28°	7/8	16.25	17.94	17.88	1.25	1.00	0.31	0.85	8
14	15.30	3.50	16.40	16.54	15.44	28°	7/8	18.75	20.31	20.25	1.31	1.25	0.31	0.89	10
16	17.40	3.50	18.50	18.64	17.54	28°	7/8	21.00	22.56	22.50	1.38	1.31	0.31	0.97	12
18	19.50	3.50	20.60	20.74	19.64	28°	7/8	23.25	24.83	24.75	1.44	1.38	0.31	1.05	12
20	21.60	3.50	22.70	22.84	21.74	28°	7/8	25.50	27.08	27.00	1.50	1.44	0.31	1.12	14
24	25.80	3.50	26.90	27.04	25.94	28°	7/8	30.00	31.58	31.50	1.62	1.56	0.31	1.22	16
30	32.00	4.00	33.29	33.46	32.17	20°	1-1/8	36.88	39.12	39.12	1.81	2.00	0.38	1.50	20
36	38.30	4.00	39.59	39.76	38.47	20°	1-1/8	43.75	46.00	46.00	2.00	2.00	0.38	1.80	24
42	44.50	4.00	45.79	45.96	44.67	20°	1-3/8	50.62	53.12	53.12	2.00	2.00	0.38	1.95	28
48	50.80	4.00	52.09	52.26	50.97	20°	1-3/8	57.50	60.00	60.00	2.00	2.00	0.38	2.20	32

23U — ANSI/AWWA C153/A21.53 MECHANICAL JOINT COMPACT DUCTILE IRON FITTINGS

Revised 2/2025 (Current revisions for the noted Standards apply)

SIZES:	2"–64" (2" not included in ANSI/AWWA C153 standard).
STANDARDS:	ANSI/AWWA C153/A21.53, NFPA13/24, 3"-16" UL and 3"-10" FM listed & approved (File - Tyler Union).
MATERIAL:	Cast of ASTM A536 qualified ductile iron. Date code is cast on and required for traceability.
PRESSURE RATING:	*Flanged fittings rated at 250 psi. Mechanical joints 2"–24" rated at 350 psi and 30"–48" at 250 psi and 54"–64" at 150 psi. *Note: With rubber annular ring flange gasket, 2"–24" Flanged fittings can be rated at 350 psi. Note: Wyes over 12" are not pressure rated. Contact Tyler Union for rating in your application.
DEFLECTION:	Joint deflection 5° max for 2"–12" and 3° max for 14"–48". Reduces by 50% at nominal pipe & fitting diameters.
NSF-61 & NSF372:	Meets all requirements, including Annex G, Tyler Union's Underwriters Laboratory listing MH16439.
ASPHALT COATING:	Per ANSI/AWWA C104/A21.4 and ANSI/AWWA C153/A21.53.
CEMENT LINING:	Per ANSI/AWWA C104/A21.4, with double cement lining available upon request.
EPOXY COATING:	Fusion-bonded epoxy per ANSI/AWWA C116/A21.16. Additional coatings available upon request.
BARE FITTINGS:	Available upon request.
FASTENERS:	High-strength low-alloy weathering steel per ANSI/AWWA C111/A21.11 and ASTM A242.
INSTALLATION:	Install per AWWA C600/C651 using pipe conforming to ANSI/AWWA C151/A21.51 or AWWA C900.

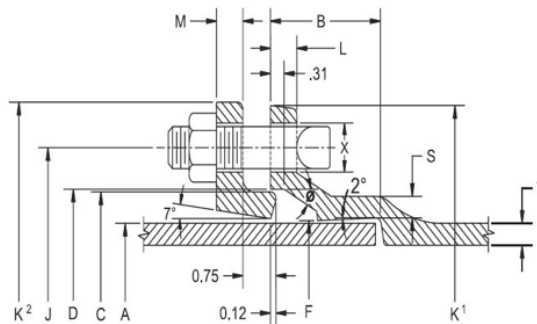

NOMINAL JOINT DIMENSIONS IN INCHES

Size (In.)	A Dia. DI Pipe	B Hub Depth	C Dia. GLAND	D Dia.	F Dia.	J Dia. GLAND	K ¹ Dia.	K ² Dia. GLAND	L	M GLAND	S	T	X	Bolt Size	Qty. Bolts
2	2.51	2.50	3.50	3.60	2.61	4.75	6.19	6.89	0.58	0.62	0.36	0.30	3/4	5/8x3	2
3	3.96	2.50	4.84	4.94	4.06	6.19	7.62	7.69	0.58	0.62	0.39	0.33	3/4	5/8x3	4
4	4.80	2.50	5.92	6.02	4.90	7.50	9.06	9.12	0.60	0.75	0.39	0.34	7/8	3/4x3-1/2	4
6	6.90	2.50	8.02	8.12	7.00	9.50	11.06	11.12	0.63	0.88	0.43	0.36	7/8	3/4x3-1/2	6
8	9.05	2.50	10.17	10.27	9.15	11.75	13.31	13.37	0.66	1.00	0.45	0.38	7/8	3/4x4	6
10	11.10	2.50	12.22	12.34	11.20	14.00	15.62	15.62	0.70	1.00	0.47	0.40	7/8	3/4x4	8
12	13.20	2.50	14.32	14.44	13.30	16.25	17.88	17.88	0.73	1.00	0.49	0.42	7/8	3/4x4	8
14	15.30	3.50	16.40	16.54	15.44	18.75	20.25	20.25	0.79	1.25	0.55	0.47	7/8	3/4x4-1/2	10
16	17.40	3.50	18.50	18.64	17.54	21.00	22.50	22.50	0.85	1.31	0.58	0.50	7/8	3/4x4-1/2	12
18	19.50	3.50	20.60	20.74	19.64	23.25	24.83	24.75	1.00	1.38	0.68	0.54	7/8	3/4x4-1/2	12
20	21.60	3.50	22.70	22.84	21.74	25.50	27.08	27.00	1.02	1.44	0.69	0.57	7/8	3/4x4-1/2	14
24	25.80	3.50	26.90	27.04	25.94	30.00	31.58	31.50	1.02	1.56	0.75	0.61	7/8	3/4x4-1/2	16
30	32.00	4.00	33.29	33.46	32.17	36.88	39.12	39.12	1.31	2.00	0.82	0.66	1-1/8	1x6	20
36	38.30	4.00	39.59	39.76	38.47	43.75	46.00	46.00	1.45	2.00	1.00	0.74	1-1/8	1x6	24
42	44.50	4.00	45.79	45.96	44.67	50.62	53.12	53.12	1.45	2.00	1.25	0.82	1-3/8	1-1/4x6-1/2	28
48	50.80	4.00	52.09	52.26	50.97	57.50	60.00	60.00	1.45	2.00	1.35	0.90	1-3/8	1-1/4x6-1/2	32
54	57.56	4.00	58.82	59.02	57.73	63.20	65.70	65.70	1.55	2.00	1.45	0.9	1-3/8	1-1/4x6-1/2	36
60	61.61	4.00	62.87	63.07	61.78	67.72	70.22	70.22	1.75	2.00	1.50	0.94	1-3/8	1-1/4x6-1/2	36
64	65.67	4.00	66.96	67.13	65.84	71.86	74.36	74.36	1.75	2.00	1.50	0.99	1-3/8	1-1/4x6-1/2	38

24U — MECHANICAL JOINT TAPPING SLEEVE FOR DUCTILE IRON, CAST IRON AND C900 PVC

Revised 2/2025 (Current revisions for the noted Standards apply)

SIZES:	6"–12" PVC/ductile pipe per ANSI/AWWA C900 or C151 and cast iron pipe as provided. Comes with 4"–12" side flanged outlet & 3/4" tap on the branch.
STANDARDS:	Mechanical and *Flanged joints comply with applicable requirements of ANSI/AWWA C153/21.53 and ASME/ANSI B16.1. Ductile iron Mechanical Joint Tapping Sleeves are produced in accordance with Tyler Union manufacturer's standard. *Note: Recess dimensions are per manufacturer's standardization society standard practice SP-60. Meets the requirements of MSS SP-111.
MATERIAL:	Cast of ASTM A536 qualified ductile iron. Date code is cast on and required for traceability.
PRESSURE RATING:	Rated at 250 psi.
DEFLECTION:	Deflection is not recommended.
GASKETS:	SBR Mechanical Joint and Split gaskets are per ASTM D2000 – AA and ANSI/AWWA C111/21.11, armor tipped with coiled brass wire spring.
NSF-61 & NSF372:	Meets all requirements, including Annex G, Tyler Union's Underwriters Laboratory listing MH16439.
ASPHALT COATING:	Per ANSI/AWWA C104/A21.4 and ANSI/AWWA C153/A21.53.
CEMENT LINING:	Tapping Sleeves are unlined to ensure they fit over the pipe being tapped.
FLANGE:	ASME/ANSI B16.1, Class 125.
FASTENERS:	High-strength low-alloy weathering steel per ANSI/AWWA C111/A21.11 and ASTM A242.
INSTALLATION:	Install per Tyler Union instructions below.

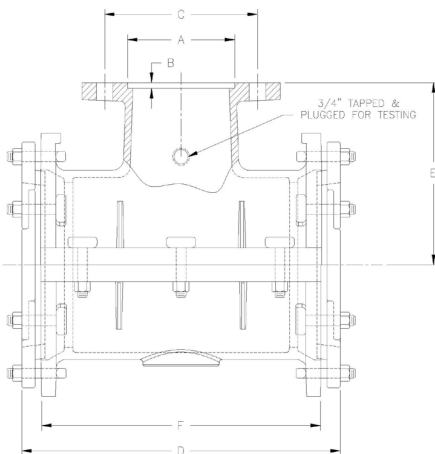

NOMINAL JOINT DIMENSIONS IN INCHES								
Size (In.)	A	B	C	D	E	F	PIPE OD RANGE	DI
6x4	5.016	0.250	7.50	15.75	8.00	12.75	6.85 - 7.15	104
6	7.016	0.312	9.50	15.75	8.00	12.75	6.85 - 7.15	108
8x4	5.016	0.250	7.50	16.50	9.00	13.38	9.00-9.35	134
8x6	7.016	0.312	9.50	16.50	9.00	13.38	9.00-9.35	140
8	9.016	0.312	11.75	16.50	9.00	13.38	9.00-9.35	148
10x4	5.016	0.250	7.50	24.00	11.00	20.75	11.04-11.45	236
10x6	7.016	0.312	9.50	24.00	11.00	20.75	11.04-11.45	240
10x8	9.016	0.312	11.75	24.00	11.00	20.75	11.04-11.45	246
10	11.016	0.312	14.25	24.00	11.00	20.75	11.04-11.45	257
12x4	5.016	0.250	7.50	26.50	12.00	23.25	13.14-13.56	273
12x6	7.016	0.312	9.50	26.50	12.00	23.25	13.14-13.56	286
12x8	9.016	0.312	11.75	26.50	12.00	23.25	13.14-13.56	292
12x10	11.016	0.312	14.25	26.50	12.00	23.25	13.14-13.56	303
12	13.016	0.312	17.00	26.50	12.00	23.25	13.14-13.56	320

INSTALLATION

- Clean pipe, insert side gasket into back half of gasket grooves. Make sure ends are flush with or slightly protrude into the end gasket seating area.
- Bolt sleeve halves together and trim side gaskets, as necessary. **MAKE SURE SLEEVE WILL ROTATE FREELY ON PIPE.**
- Install end gaskets, locating cut ends 90° from side gasket. If pipe is maximum OD, stretch gasket to make certain cut ends match with no gap in between.
- Install glands and bolts — rotate sleeve to desired position. Be sure pipe is centered inside the sleeve.
- Tighten gland bolts alternately, using 80 to 90 ft-lb.
- After assembly, **pressure test all joints before tapping.** If additional tightening is required, release pressure and relax tension on gland bolts before tightening side bolts.

25U — ANSI/AWWA C153/A21.53 UNION-TITE COMPACT DUCTILE IRON FITTINGS

Revised 02/2025 (Current revisions for the noted Standards apply)

SIZES:	4"–24"
STANDARDS:	ANSI/AWWA C153/A21.53, NFPA13/24, 4"–12" UL listed & approved (File - Tyler Union).
MATERIAL:	Cast of ASTM A536 qualified ductile iron. Date code is cast on and required for traceability.
PRESSURE RATING:	Union-Tite/Push-on Joints 4"–24" rated at 350 psi. *Flanged fittings rated at 250 psi. *Note: With rubber annular ring flange gasket, 4"–24" Flanged fittings can be rated at 350 psi. Note: Wyes over 12" are not pressure rated. Contact Tyler Union for rating in your application.
DEFLECTION:	Joint deflection 5° max for 4"–12" and 3° max for 14"–24". Reduces by 50% at nominal pipe & fitting diameters.
NSF-61 & NSF372:	Meets all requirements, including Annex G, Tyler Union's Underwriters Laboratory listing MH16439.
ASPHALT COATING:	Per ANSI/AWWA C104/A21.4 and ANSI/AWWA C153/A21.53.
CEMENT LINING:	Per ANSI/AWWA C104/A21.4, with double cement lining available upon request.
EPOXY COATING:	Fusion-bonded epoxy per ANSI/AWWA C116/A21.16. Additional coatings available upon request.
BARE FITTINGS:	Available upon request.
FASTENERS:	High-strength low-alloy weathering steel per ANSI/AWWA C111/A21.11 and ASTM A242.
RESTRAINING LUGS:	*Lugs provided on 16" and smaller fittings. Lug pattern accommodates most grip type restraints. *NOTE: With sufficient lead time to adapt tooling, restraining lugs are available on 18"–24" fittings.
INSTALLATION:	Install per AWWA C600/C651 using pipe conforming to ANSI/AWWA C151/A21.51 or AWWA C900. Designed for use with TYTON® and McWane SURE STOP® gaskets. Contact Tyler Union regarding the installation or use of other gasket types and/or gasket manufacturers.

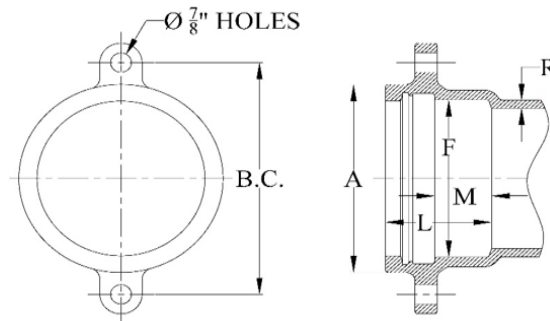

NOMINAL JOINT DIMENSIONS IN INCHES							
Size (In.)	Pipe Diameter	A Diam.	F Diam.	B.C. Diam.	L Diam.	M Diam.	R Diam.
4	4.80	6.38	5.04	7.88	4.16	2.25	0.35
6	6.90	8.52	7.14	10.50	4.29	2.25	0.37
8	9.05	10.90	9.32	12.88	4.78	2.25	0.39
10	11.10	12.91	11.37	14.69	4.98	2.25	0.41
12	13.20	15.12	13.47	17.19	4.98	2.25	0.43
14	15.30	18.12	15.64	19.00	5.40	2.25	0.51
16	17.40	20.32	17.74	21.40	5.40	2.25	0.52
18	19.50	22.52	19.83	—	5.40	2.25	0.59
20	21.60	24.29	21.94	—	5.40	2.25	0.60
24	25.80	29.14	26.14	—	5.65	2.50	0.62

26U — ANSI/AWWA C110/A21.10 COMPANION/ THREADED FLANGE DUCTILE IRON FITTINGS

Revised 2/2025 (Current revisions for the noted Standards apply)

SIZES:	2"–64"
STANDARDS:	ANSI/AWWA C110/A21.10, NFPA 13/24, ASME B16.1, ANSI/AWWA C115/A21.15.
MATERIAL:	Cast of ASTM A536 qualified ductile iron. Date code is cast on and required for traceability.
PRESSURE RATING:	Flanged fittings *2"–48" rated at 250 psi. 54"–64" rated at 150 psi.
DEFLECTION:	Deflection is not recommended for flange joint due to the rigidity of the joint.
COATING:	Asphaltic or primer per ANSI/AWWA C104/A21.4. Standard primer is Tnemec Pota Pox N140-1211. Contact Tyler Union for additional coating options.
BARE FITTINGS:	Available upon request.
THREADS:	Tapered pipe threads as per NPT ANSI B1.20.1. Available for ductile iron pipe as well as steel pipe. NOTE: Please specify pipe type upon order placement.
FLANGES:	ANSI Class 125 per ASME B16.1 and ANSI/AWWA C111/A21.11. NOTE: Class 125 ASME B16.1 are not compatible with Class 250 flanges. NOTE: Class 250 ASME B16.1 fittings are available upon request.
INSTALLATION:	Install per AWWA C600/C651 using pipe conforming to ANSI/AWWA C151/A21.51.

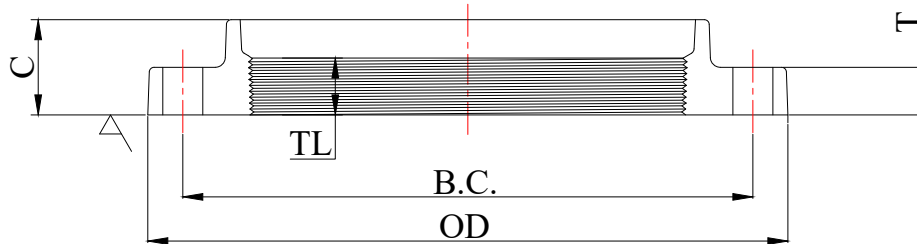

COMPANION FLANGE DETAILS IN INCHES									
Size (In.)	Diameter DI Pipe	Flange O.D.	B.C. Diameter	Flange Thickness T	Flange Height C	Thread Length TL	Bolt Hole Diameter	Bolt Size	Qty. Bolts
2	2.51	6.00	4.75	0.62	1.25	1.06	0.75	5/8 x 2-1/4	4
3	3.96	7.50	6.00	0.75	1.75	1.06	0.75	5/8 x 2-1/4	4
4	4.80	9.00	7.50	0.94	1.87	1.19	0.75	5/8 x 3	8
6	6.90	11.00	9.50	1.00	2.06	1.38	0.875	3/4 x 3-1/2	8
8	9.05	13.50	11.75	1.12	2.30	1.56	0.875	3/4 x 3-1/2	8
10	11.10	16.00	14.25	1.19	2.50	1.75	1.00	7/8 x 4	12
12	13.20	19.00	17.00	1.25	2.62	2.00	1.00	7/8 x 4	12
14	15.30	21.00	18.75	1.38	2.70	2.01	1.125	1 x 4-1/2	12
16	17.40	23.50	21.25	1.44	2.70	2.25	1.125	1 x 4-1/2	16
18	19.50	25.00	22.75	1.56	2.82	2.45	1.25	1-1/8 x 5	16
20	21.60	27.50	25.00	1.69	2.93	2.62	1.25	1-1/8 x 5	20
24	25.80	32.00	29.50	1.88	3.17	2.96	1.375	1-1/4 x 5-1/2	20
30	32.00	38.75	36.00	2.12	4.00	3.37	1.375	1-1/4 x 5-1/2	28
36	38.30	46.00	42.75	2.38	5.00	4.00	1.625	1-1/2 x 7	32
42	44.50	53.00	49.50	2.62	5.12	4.50	1.625	1-1/2 x 7-1/2	36
48	50.80	59.50	56.00	2.75	5.50	5.12	1.625	1-1/2 x 8	44
54	57.56	66.25	62.75	3.00	7.16	6.18	2.00	1-3/4 x 8-1/2	44
60	61.61	73.00	69.25	3.12	7.16	6.18	2.00	1-3/4 x 9	52
64	65.67	80.00	76.00	3.38	7.16	6.18	2.00	1-3/4 x 9	52

27U — AWWA C111/A21.11 DUCTILE IRON ADAPTER FLANGE

Revised 02/2025 (Current revisions for the noted Standards apply)

SIZES:	3"–12" — Recommended for use with Class 53–Class 56 ductile iron pipe.
STANDARDS:	ANSI/AWWA C110/A21.10, ANSI/AWWA C111/A21.11, UL listed and FM approved.
MATERIAL:	Cast of ASTM A536 qualified ductile iron. Date code is cast on and required for traceability.
PRESSURE RATING:	Flanged fittings 3"–10" rated at 250 psi and 12" rated at 150 psi.
DEFLECTION:	Max joint deflection 2°, reduces by 50% at nominal pipe and fitting diameters.
NSF-61 & NSF372:	Meets all requirements, including Annex G, Tyler Union's Underwriters Laboratory listing MH16439.
COATING:	Tnemec Pota Pox N140-1211.
BOLTS:	ANSI/AWWA C110/A21.10 and ANSI/AWWA C111/A21.11, for assembly use AWWA C110 length hex head bolts. The torque head bolts are socket head and with Type C knurled cup points, 4140 grade alloy steel that is heat treated to a Rockwell "C" 45/53 case hardness and shipped assembled in the adapter. Torque head will break off at 80–90 ft-lb.
INSTALLATION:	Install per Tyler Union instructions below.

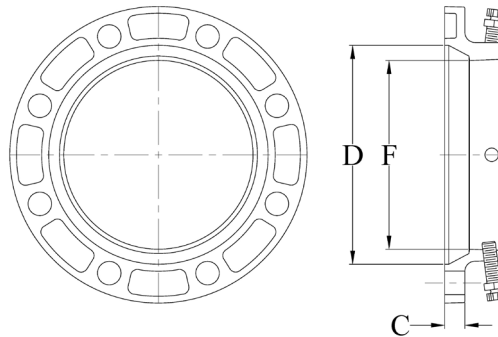

ADAPTER FLANGE DIMENSIONS IN INCHES

Size	Rated Working Pressure	No. of Set Screws	Bolt Circle	D.I.	Pipe O.D.	D + .06 – .04	F + .07 – .03	C	Weight
				+ .06 / - .06					
3	3	4	6.00	3.96		4.64	4.06	0.94	7
4	4	4	7.50	4.80		6.02	4.90	1.00	10
6	6	8	9.50	6.90		8.12	7.00	1.06	14
8	8	8	11.75	9.05		10.27	9.15	1.12	22
10	10	12	14.25	11.10		12.34	11.20	1.19	30
12	12	12	17.00	13.20		14.44	13.30	1.25	40

INSTALLATION

- Place adapter flange and the gasket over the plain end of the pipe with the small side of the MJ gasket facing the flange side of the adapter flange.
- Place the pipe end against the flange to be joined and slip the MJ gasket into place against the flange. Make sure the gasket is evenly seated against the flange.
- Slide the adapter flange into position against the small (tapered) side of the MJ gasket and align the bolt holes. Insert the bolts and finger tighten the nuts to maintain position and alignment.
- Snug up all nuts evenly, alternating 180°. Tighten the nuts to a torque of 60 ft-lb for 3" and 90 ft-lb for 4"–12".
- Snug set screws evenly, alternating 180°, tighten set screws to 80–90 ft-lb.

28U — ANSI/AWWA C110/A21.10 C110 FLANGE JOINT CLASS 125 PRODUCT

Revised 2/2025 (Current revisions for the noted Standards apply)

SIZES:	2"–64"
STANDARDS:	ANSI/AWWA C110/A21.10, NFPA 13/24, ASME B16.1, 3"–12" UL listed and FM approved.
MATERIAL:	Cast of ASTM A536 qualified ductile iron. Date code is cast on and required for traceability.
PRESSURE RATING:	*Flanged fittings *2"–48" rated at 250 psi. 54"–64" rated at 150psi. *Note: With rubber annular ring flange gasket, 2"–24" flanged fittings can be rated at 350 psi.
DEFLECTION:	Deflection is not recommended for flange joint due to the rigidity of the joint.
NSF-61 & NSF372:	Meets all requirements, including Annex G, Tyler Union's Underwriters Laboratory listing MH16439.
COATING:	Asphaltic or Primer per ANSI/AWWA C104/A21.4, Standard primer is Tnemec Pota Pox N140-1211. Contact Tyler Union for additional coating options.
CEMENT LINING:	Per ANSI/AWWA C104/A21.4, with double cement lining available upon request.
EPOXY COATING:	Fusion-bonded epoxy per ANSI/AWWA C116/A21.16. Additional coatings available upon request.
BARE FITTINGS:	Available upon request.
FLANGES:	ANSI Class 125 per ASME B16.1 and ANSI/AWWA C111/A21.11. Bolt holes shall straddle the center line. NOTE: Class 125 ASME B16.1 are not compatible with Class 250 Flanges. NOTE: Class 250 ASME B16.1 fittings are available upon request.
FASTENERS:	High-strength low-alloy weathering steel per ANSI/AWWA C111/A21.11 and ASTM A242.
INSTALLATION:	Install per AWWA C600/C651 using pipe conforming to ANSI/AWWA C151/A21.51.

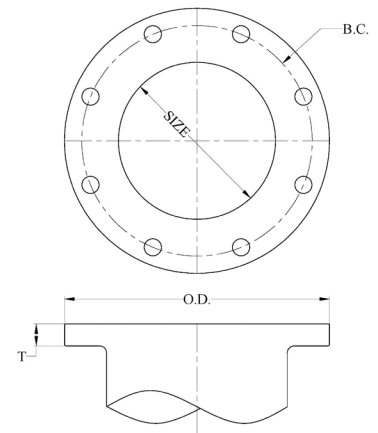

FLANGE DETAILS IN INCHES							
Size (In.)	Diameter DI Pipe	Flange O.D.	B.C. Diameter	Flange Thickness T	Bolt Hole Diameter	Bolt Size	Qty. Bolts
2	2.51	6.00	4.75	0.62	0.750	5/8 x 2-1/4	4
3	3.96	7.50	6.00	0.75	0.750	5/8 x 2-1/4	4
4	4.80	9.00	7.50	0.94	0.750	5/8 x 3	8
6	6.90	11.00	9.50	1.00	0.875	3/4 x 3-1/2	8
8	9.05	13.50	11.75	1.12	0.875	3/4 x 3-1/2	8
10	11.10	16.00	14.25	1.19	1.000	7/8 x 4	12
12	13.20	19.00	17.00	1.25	1.000	7/8 x 4	12
14	15.30	21.00	18.75	1.38	1.125	1 x 4-1/2	12
16	17.40	23.50	21.25	1.44	1.125	1 x 4-1/2	16
18	19.50	25.00	22.75	1.56	1.250	1-1/8 x 5	16
20	21.60	27.50	25.00	1.69	1.250	1-1/8 x 5	20
24	25.80	32.00	29.50	1.88	1.375	1-1/4 x 5-1/2	20
30	32.00	38.75	36.00	2.12	1.375	1-1/4 x 6-1/2	28
36	38.30	46.00	42.75	2.38	1.625	1-1/2 x 7	32
42	44.50	53.00	49.50	2.62	1.625	1-1/2 x 7-1/2	36
48	50.80	59.50	56.00	2.75	1.625	1-1/2 x 8	44
54	57.56	66.25	62.75	3.00	2.000	1-3/4 x 8-1/2	44
60	61.61	73.00	69.25	3.12	2.000	1-3/4 x 9	52
64	65.67	80.00	76.00	3.38	2.000	1-3/4 x 9	52

28U-B — ANSI/AWWA C110/A21.10 C110 FLANGE JOINT CLASS 250 PRODUCT

Revised 02/2025 (Current revisions for the noted Standards apply)

SIZES:	2"–48"
STANDARDS:	ANSI/AWWA C110/A21.10, NFPA 13/24, ASME B16.1.
MATERIAL:	Cast of ASTM A536 qualified ductile iron. Date code is cast on and required for traceability.
PRESSURE RATING:	*Flanged fittings *2"–48" rated at 250 psi. *Note: With rubber annular ring flange gasket, 2"–24" flanged fittings can be rated at 350 psi.
DEFLECTION:	Deflection is not recommended for flange joint due to the rigidity of the joint.
NSF-61 & NSF372:	Meets all requirements, including Annex G, Tyler Union's Underwriters Laboratory listing MH16439.
COATING:	Asphaltic or Primer per ANSI/AWWA C104/A21.4. Standard primer is Tnemec Pota Pox N140-1211. Contact Tyler Union for additional coating options.
CEMENT LINING:	Per ANSI/AWWA C104/A21.4, with double cement lining available upon request.
EPOXY COATING:	Fusion-bonded epoxy per ANSI/AWWA C116/A21.16. Additional coatings available upon request.
BARE FITTINGS:	Available upon request.
FLANGES:	ANSI Class 250 per ASME B16.1 and ANSI/AWWA C111/A21.11. Bolt holes shall straddle the center line. NOTE: Class 250 ASME B16.1 are not compatible with Class 125 Flanges. NOTE: Class 250 ASME B16.1 fittings are available upon request.
FASTENERS:	High-strength low-alloy weathering steel per ANSI/AWWA C111/A21.11 and ASTM A242.
INSTALLATION:	Install per AWWA C600/C651 using pipe conforming to ANSI/AWWA C151/A21.51.

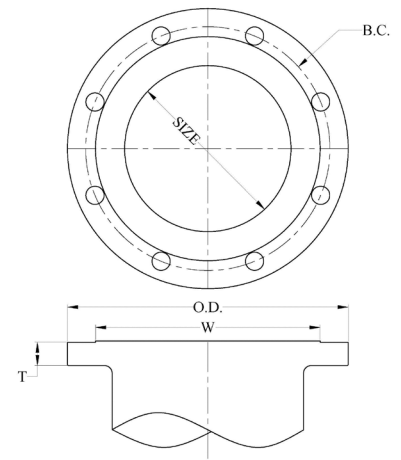

CLASS 250 FLANGE DETAILS IN INCHES								
Size (In.)	Diameter DI Pipe	Flange O.D.	W (Raised Face)	B.C. Diameter	Flange Thickness T	Bolt Hole Diameter	Bolt Size	Qty. Bolts
2	2.51	6.50	4.19	5.00	0.88	0.75	5/8 x 3	8
3	3.96	8.25	5.69	6.62	1.12	0.875	3/4 x 3-1/2	8
4	4.80	10.00	6.94	7.88	1.25	0.875	3/4x4	8
6	6.90	12.50	9.69	10.62	1.44	0.875	3/4 x 4	12
8	9.05	15.00	11.94	13.00	1.62	1.000	7/8 x4-1/2	12
10	11.10	17.50	14.06	15.25	1.88	1.125	1.0x5-1/2	16
12	13.20	20.50	16.44	17.75	2.00	1.250	1-1/8 x5-1/2	16
14	15.30	23.00	18.94	20.25	2.12	1.250	1-1/8 x 6	20
16	17.40	25.50	21.06	22.50	2.25	1.375	1-1/4x 6-1/2	20
18	19.50	28.00	23.31	24.75	2.38	1.375	1-1/4 x 6-1/2	24
20	21.60	30.50	25.56	27.00	2.50	1.375	1-1/4 x7	24
24	25.80	36.00	30.31	32.00	2.75	1.625	1-1/2 x 7-1/2	24
30	32.00	43.00	37.19	39.25	3.00	2.000	1-3/4 x 8-1/2	28
36	38.30	50.00	43.69	46.00	3.38	2.250	2x9-1/2	32
42	44.50	57.00	50.44	52.75	3.69	2.250	2x10	36
48	50.80	65.00	58.44	60.75	4.00	2.250	2x11	40

29U — BOLTS AND NUTS FOR MECHANICAL JOINTS

Revised 02/2025 (Current revisions for the noted Standards apply)

SIZES:	5/8 x 3 through 1-1/4 x 8-1/2.
STANDARDS:	ANSI/AWWA C111/A21.11.
MATERIAL:	ASTM A242 high-strength low-alloy steel. Also available in ANSI 304 or ANSI 316 AISI Stainless Steel.
COATING:	Standard nuts and bolts are not coated. Fluoropolymer coating is available upon request. Fluoropolymer is Fluorokote #1 (blue for low alloy steel).
FASTENERS:	High-strength low-alloy weathering steel per ANSI/AWWA C111/A21.11 and ASTM A242.

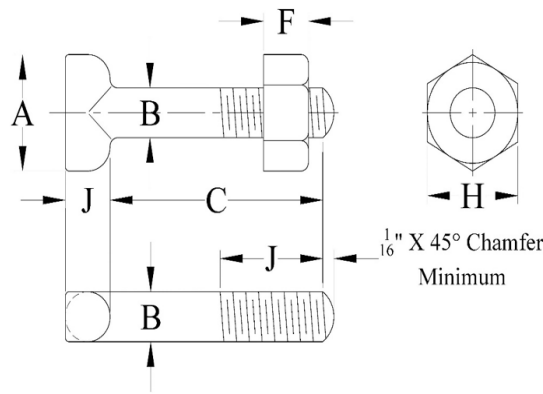

NOMINAL JOINT DIMENSIONS IN INCHES

Size (In.)	A ± 0.05	B +0.03 / -0.074	C +0.25 / -0.06	F	H	J +0.15 / -0.03	R Max	D*	Threads Per Inch E**
5/8 x 3	1.5	0.625	3.00	0.625	1.062	0.625	0.312	2.00	11
3/4 x 3-1/2	1.75	0.750	3.50	0.750	1.250	0.750	0.375	2.50	10
3/4 x 4	1.75	0.750	4.00	0.750	1.250	0.750	0.375	3.00	10
3/4 x 4-1/2	1.75	0.750	4.50	0.750	1.250	0.750	0.375	3.00	10
3/4 x 5	1.75	0.750	5.00	0.750	1.250	0.750	0.375	3.00	10
1 x 6	1.75	1.000	6.00	1.000	1.625	1.000	0.500	3.00	8
1 x 7-1/2	2.25	1.000	7.50	1.000	1.625	1.000	0.625	4.50	8
1-1/4 x 6-1/2	2.50	1.250	6.50	1.250	2.000	1.250	0.750	3.50	7
1-1/4 x 8-1/2	2.50	1.250	8.50	1.250	2.000	1.250	0.750	4.00	7

NOTES:

- Dimension B is unthreaded shank.
- Draft, when required to be 6° maximum, may be deducted from bolt head dimensions, and radius may be changed to suit draft.
- Gates, if required, may protrude a maximum of 1/8" above the top of the bolt head.
- Chamfer is optional if threads are rolled.
- If threads are rolled, the body diameter may be reduced to the approximate pitch diameter of the thread.

Note: Tolerance +3/-0 thread.

Note: Number of threads per inch — coarse-thread series (ANSI/ASME B1.1), class 2A, external fit UNC2A and class 2B, UNC2B (ANSI/ASME B1.2).

(3) If seal coat paint is used during field repair, allow a cure time of 48 hours after the seal coat is applied before placing fitting back in service.

30U — STANDARD MECHANICAL & PUSH-ON JOINT GASKETS

(SBR, NBR, EPDM, NEOPRENE, FKM)

Revised 2/2025 (Current revisions for the noted Standards apply)

Tyler Union Waterworks provides that our *Mechanical and Push-On joint gaskets and dimensions conform to the specifications in ANSI/AWWA C111/A21.11 (current revision). Markings include size, mold number, gasket manufacturer’s mark, country where molded and product identification letters. No markings are placed on sealing surfaces per the AWWA C111 standard.

***Note:** Push-On and Mechanical Joint transition gasket design standards and markings are not addressed by ANSI/AWWA C111/A21.11 (current revision). Transition gaskets provided by Tyler Union follow the material testing standards and specifications established for ANSI/AWWA C111/A21.11 gaskets.

Gasket material is vulcanized styrene butadiene rubber (SBR). Purchaser may request special application elastomers (EPDM,

Nitrile, Neoprene & FKM), which will be identified on all documentation and corresponding gaskets. Gaskets are free of foreign materials, porous areas or other defects that make them unfit for the intended use.

Tyler Union gaskets are manufactured under quality control standards and procedures that are maintained by the gasket supplier. Appropriate documentation is maintained by the manufacturer and available for review upon request. Properties and test methods for SBR, EPDM, Nitrile, Neoprene and FKM gaskets are as provided.

Property	ASTM Test Method	Required Value
Hardness, Shore "A"	D2240-86	75 (+-5)
Minimum Tensile	D412-87	1500 psi (10MPa)
Minimum Elongation	D412-87	150%
Minimum Aging	D572-88	60%
Maximum Compression Set	D395-89, Method B	20%
Resistance to surface	D1149-86	No cracking
Ozone cracking		

Tyler Union’s approved suppliers maintain a quality assurance program that is reviewed and updated on an ongoing basis to ensure product quality. Tyler Union’s gasket suppliers submit gaskets for testing and provide materials for testing to Underwriters Laboratories, Inc. Tyler Union’s gasket providers are recognized under the component program (UL 194/ UL 157) of Underwriters Laboratories, Inc. Tyler Union UL approved gaskets meet NSF-61, NSF-372 and Annex G.

Tyler Union provides that our Mechanical and Push-On joint gaskets for potable or wastewater projects will perform as designed when selected per the chart provided and installed per AWWA C600-10.

SBR (STYRENE BUTADIENE RUBBER) (BUNA-S) Not recommended for hydrocarbon service.	20°F to 180°F	Suitable for water, wastewater, most moderate chemicals, wet or dry organic acids, alcohols, ketones and aldehydes.
EPDM (ETHYLENE PROPYLENE) Not recommended for hydrocarbon service.	-10°F to 250°F	Ideal for water, wastewater, ozone and strong oxidizing chemicals. May be used on steam and air within its temperature range.
CR (NEOPRENE)	-10°F to 200°F	Recommended for moderate chemicals and acids, oil fats, greases, many solvents and air with hydrocarbons. Will not support combustion.
NBR (NITRILE)(BUNA-N)(HYCAR)	-40°F to 250°F	Ideally suited for gasoline, petroleum products, hydrocarbons, water, mineral and vegetable oils.
*FKM (FLUOROELASTOMER) *Check with customer service for availability.	10°F to 425°F	Ideally suited for hydrocarbons, acids, vegetable oils and petroleum.
GASKET TYPES OFFERED:		(1) Mechanical Joint std. (2) Push-On Joint std. (3) Mechanical Joint DUO (4) Mechanical and Push-on Joint Transition (5) Push-on Restraining (6) Mechanical Joint Armor Tip Conductivity (7) Compact tapping Sleeve
NOTE: Unless other wise requested by the purchaser upon order placement, all gaskets provided will be of our standard SBR material.		

MECHANICAL JOINT GASKETS/ANSI/AWWA C111/A21.11-12/*MJ TRU-LOCK GASKETS 30"-48" INCH								
Pipe Size (In.)	Pipe O.D.	A +0.01"	B	C	D	E	F	G
**2	2.50	0.48	0.62	0.31	2.48	0.12	0.15	1.05
3	3.96	0.48	0.62	0.31	3.86	0.12	0.15	1.05
4	4.80	0.62	0.75	0.31	4.68	0.16	0.22	1.22
6	6.90	0.62	0.75	0.31	6.73	0.16	0.22	1.22
8	9.05	0.62	0.75	0.31	8.85	0.16	0.22	1.22
10	11.10	0.62	0.75	0.31	10.87	0.16	0.22	1.22
12	13.20	0.62	0.75	0.31	12.95	0.16	0.22	1.22
14	15.30	0.62	0.75	0.31	14.99	0.16	0.22	1.22
16	17.40	0.62	0.75	0.31	17.07	0.16	0.22	1.22
18	19.50	0.62	0.75	0.31	19.13	0.16	0.22	1.22
20	21.60	0.62	0.75	0.31	21.20	0.16	0.22	1.22
24	25.80	0.62	0.75	0.31	25.34	0.16	0.22	1.22
30	32.00	0.73	1.00/* .50	.38/* .50	31.47	0.16	.37/* .55	1.54/*1.16
36	38.30	0.73	1.00/* .50	.38/* .50	37.67	0.16	.37/* .55	1.54/*1.16
42	44.50	0.73	1.00/* .50	.38/* .50	43.78	0.16	.37/* .55	1.54/*1.16
48	50.80	0.73	1.00/* .50	.38/* .50	49.98	0.16	.37/* .55	1.54/*1.16

** Not included in AWWA C111. Manufacturer's Standard does not meet AWWA C111.

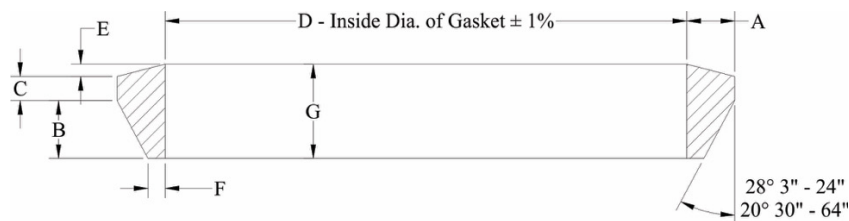

** MECHANICAL JOINT TRANSITION GASKET DIMENSIONS IN INCHES							
Pipe Size (In.)	A ± 0.01"	B	C	D ± 1%	E	F ± 0.01"	G ± 0.02"
2	0.57	0.62	0.31	2.28	0.16	0.24	1.08
3	0.70	0.62	0.31	3.45	0.16	0.37	1.11
4	0.77	0.75	0.31	4.43	0.16	0.37	1.26
6	0.76	0.75	0.31	6.53	0.16	0.36	1.25
8	0.82	0.75	0.31	8.50	0.16	0.42	1.27
10	0.79	0.75	0.31	10.59	0.16	0.39	1.26
12	0.84	0.75	0.31	12.56	0.16	0.44	1.28

** Not included in AWWA C111. Manufacturer's Standard does not meet AWWA C111.

37U — TU G05 SERIES VALVE BOX & LID

Revised 02/2025 (Current revisions for the noted Standards apply)

STANDARDS:	Produced in accordance with and meeting applicable terms and provisions of ASTM A-48. All Tyler Union valve boxes when properly installed are suitable for use in conjunction with projects utilizing American Association of State and Highway Transportation Officials (AASHTO) standards. AASHTO compliance with H20 and H40 traffic loading.
INSTALLATION:	Per AWWA M44, Manual of Water Supply Practices.
COATING:	The asphaltic bituminous coating is applied to a minimum of 1.5 mil and the coating once dry is neither brittle when cold or sticky when exposed to the sun.
FEATURES:	<ul style="list-style-type: none"> • Lid provided with longer tynees to prevent movement. • Lids are available with "WATER", "SEWER" or blank marking. • Specialty marking available in domestic only; contact Tyler Union for more details. Available in an assembly, or pieces sold individually. • Straight body allows for easy assembly on AWWA C900 PVC Pipe. • Valve Box ribs provided to prevent movement. • No pre-cast required. • Import Box provided drilled and tapped for 1/4"-20 screw (screw not provided) • Domestic boxes can be drilled and tapped 1/4"-20 upon request. (screw not provided)
COATING:	Asphaltic or Primer per ANSI/AWWA C104/A21.4. Standard primer is Tnemec Pota Pox N140-1211. Contact Tyler Union for additional coating options.
WEIGHTS:	<ul style="list-style-type: none"> • Body: 42lbs. • Lid: 16lbs.

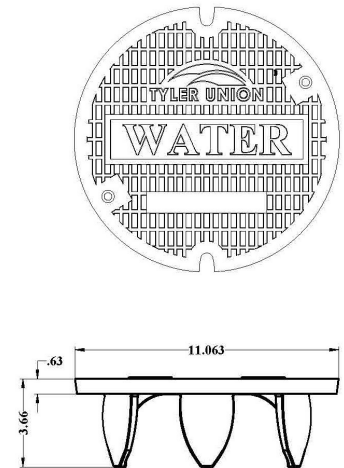
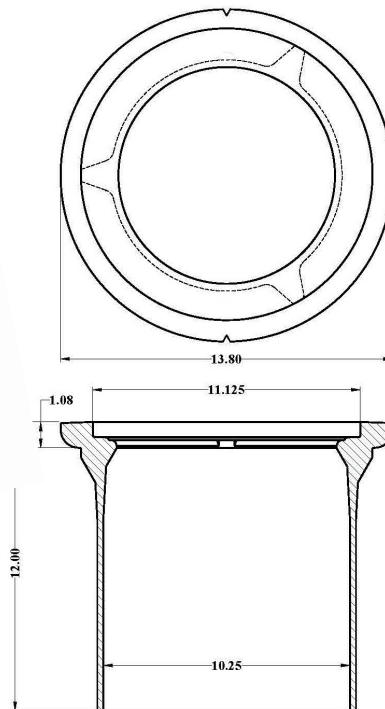



POCKET ENGINEER
Available for iOS + Android
or online at pe.mcwane.com.

TylerUnion.com